

The

**RADIO
NEWS**

**Super-
Heterodyne
Book**

Price
50¢

Experimenter Publishing Co.
NEW YORK CITY

The New

**RADIO
NEWS**

At All
Newsstands

Amateurs' Handibook

118 Hookups ~ Over 300 Illustrations

Contents
of
this Issue

In the latest revised issue of RADIO NEWS AMATEUR'S HANDBOOK, there is a collection of the very best articles that have been published in RADIO NEWS, Radio's Greatest Magazine, these articles having been selected so that every group of radio fans will find something to interest them. There are sets and how to build them for the broadcast listener and there are circuits and transmitting information for the Amateur. There are hints and wrinkles for the experimenter and builder and there are 118 standard circuit diagrams of general interest to all. In the division for the broadcast listener, only those sets are described and illustrated that are new practical and efficient. The same applies to the Amateur section where much worth while information on the new short waves will be found. Transmitting and receiving sets capable of working over thousands of miles are described in detail and data is given for the construction of each one. No effort has been spared to make the book the most complete and concise source of information that could be had. Each article was carefully selected from long lists of data, special care was taken to approve of only those articles of practical use. All descriptions and illustrations of circuits are written in a simple, constructional nature so that all readers will quickly grasp the details.

The RADIO AMATEURS' HANDBOOK is for everybody. It is a complete authentic record of the best radio developments of the day. It is a sure, ready reference, good to have on hand at all times.

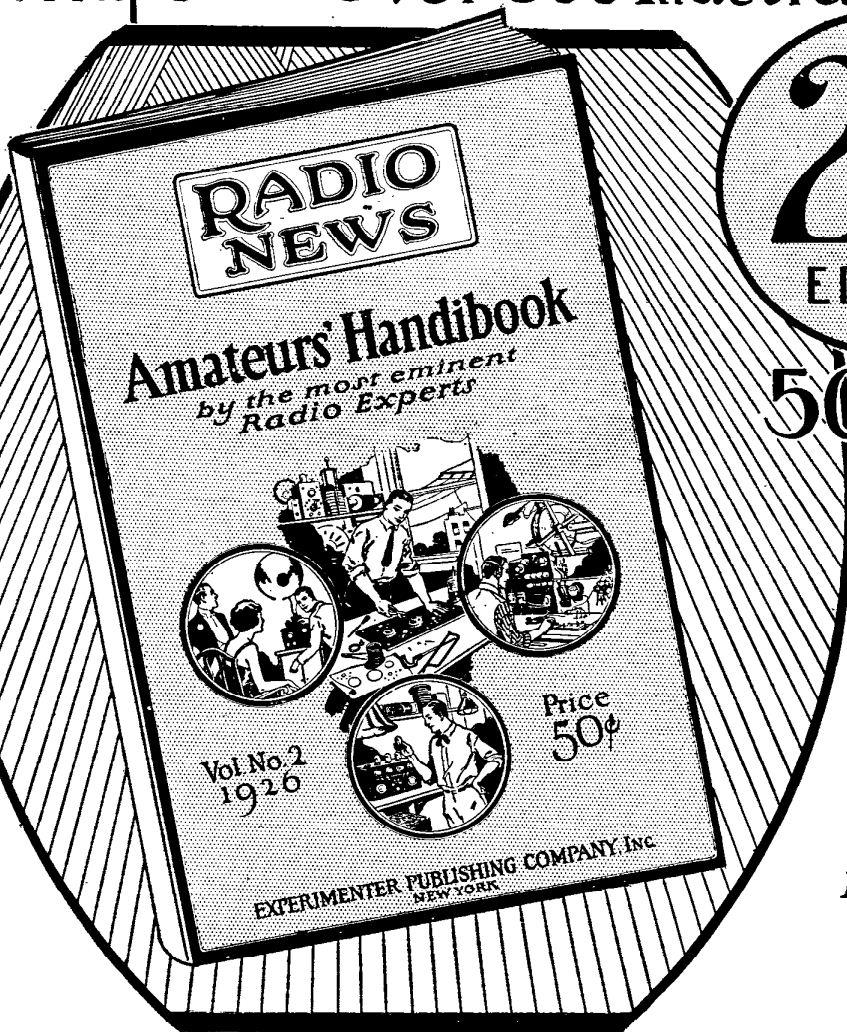

2nd
EDITION

50 CENTS
THE COPY

All New
Articles
New
Hookups
New
Information
New Data

The Reference Book of Radio Facts!

Any electrician will tell you that his Electrical Handbook is his most valuable reference—so also, the builder, the mason, the carpenter, all use a handy reference book no matter what the job may be. It is as important as the tools they use to work with.

EVERY MAN SHOULD HAVE A RADIO HANDBOOK, the real, concise, yet comprehensive book on everything of reference value to anyone interested in radio whether he builds his own set or is engaged in professional radio activity.

All information for this book has been carefully

culled from the pages of no less authority than Radio's Greatest Magazine, RADIO NEWS. Radio men in constant touch with all radio material have selected the most valuable articles.

The RADIO NEWS AMATEURS' HANDBOOK contains a complete resume of every phase of radio. It is the first book of its kind, a veritable gold mine of radio information.

Published in the large size 9 by 12 inches, contains 128 pages, illustrated.

PRICE 50 CENTS THE COPY

Published and Distributed by EXPERIMENTER PUB. CO., Inc., 53 Park Pl., New York, N. Y.

Miss [unclear] [unclear]
511 - [unclear]

THE

**RADIO
NEWS**

SUPERHETERODYNE
BOOK

A collection of Important Articles covering the construction and operation of every known type of Superheterodyne Receiver with a special supplement describing all patents touching on Superheterodynes.

EXPERIMENTER PUBLISHING CO.

53 PARK PLACE, NEW YORK

Publishers of

**RADIO NEWS, SCIENCE & INVENTION, AMAZING STORIES, RADIO REVIEW
and RADIO INTERNACIONAL**

Table of Contents

	Page		Page
Foreword	3	Best's 45,000 Cycle Superheterodyne.....	48
Notes on the Superheterodyne.....	4	By G. M. Best	
By Prof. Grover Ira Mitchell		The Modified Best Superheterodyne.....	53
Superheterodyne Circuits	6	By G. M. Best	
A 3000-Mile Superheterodyne.....	9	The Modified Best Superheterodyne.....	58
By R. A. Stuart-Frey		By G. M. Best	
An Improved Laboratory Superheterodyne.....	11	Improvements in the 45,000 Cycle Superheterodyne.....	63
By Ernest R. Pfaff		By G. M. Best	
The Cotton Superheterodyne.....	13	More Improvements in Best's 45,000 Cycle Super- heterodyne	64
How to Construct the Hetro Five.....	17	By G. M. Best	
A New Superheterodyne.....	20	The "Peanut" Super.....	65
By McMurdo Silver		By Morris Levy	
The Midget Super.....	23	The Ultradyne Receiver.....	67
A Powerful Six-Tube Superheterodyne.....	26	By Robert E. Lacault, A.M.I.R.E.	
Everyman's Receiver—The Fenway.....	28	The Ultradyne Receiver, Part II.....	70
By Leo Fenway		By Robert E. Lacault, A.M.I.R.E.	
Everyman's Receiver—The Fenway, Part II.....	30	Construction of the Ultradyne, L-2.....	72
By Leo Fenway		A Noiseless Intermediate Amplifier.....	74
Second Harmonic Superheterodyne.....	32	By G. C. B. Rowe	
By L. R. Felder		Putting the Superheterodyne on Wheels.....	75
A Neatly Designed Superheterodyne.....	33	By S. R. Winters	
The Most Novel Superheterodyne.....	35	Data on the New Pressley Superheterodyne.....	76
By D. C. Wilkerson		Matching Tubes for Superheterodynes.....	78
Matching Intermediate Wave Transformers for Superheterodynes	37	By S. Young White	
By Prof. Grover Ira Mitchell		Adjusting Your Superheterodyne.....	79
The Tropadyne Circuit.....	38	By L. H. La Montagne	
By Clyde J. Fitch		Patents Involving Superheterodyne Principles.....	82
How to Build the Popular Mechanics' Superhetero- dyne Eight	42		

Copyright by
EXPERIMENTER PUBLISHING CO., INC.

1926

All rights reserved, including that of translation into foreign languages, including the Scandinavian.

Printed in the United States of America,

Foreword

By CLYDE J. FITCH
(Inventor of the Tropadyne)

WITH radio engineers and other radio authorities advocating the Superheterodyne in all instances where extreme sensitivity and distance reception are required, there is little wonder that this type of receiver reached a high state of popularity in this country and abroad among the broadcast fans and experimenters. Authentic reports of extreme distance reception by various radio fans when using the Superheterodyne with a small loop aerial, or in some cases with no aerial at all, contributed to its popularity. But many who purchased the necessary parts and spent many hours in building a Superheterodyne were greatly disappointed, after long hours of anticipation, to find that only local stations could be received on the particular model built. They came to the natural conclusion that either the Superheterodyne is not all that is claimed of it, or that the apparatus used in building the set was faulty. Therefore, let us carefully analyze the Superheterodyne from the theoretical standpoint and see just why it is considered the most sensitive receiver by many radio authorities.

There is a limit to the sensitivity of the ordinary vacuum tube type of radio set. In practice this limit is usually determined by the amount of static and other interference present. During unusually good radio conditions with a minimum of static and interference from nearby stations, great distances can be covered. When a large amount of static is in the air, only local stations can be heard. The reason for this is obvious; if the signal is of about the same strength as the static, or less, the static drowns out the signal and it is lost. It cannot be tuned in by adding amplification. This merely magnifies the static in proportion to the signal.

The sensitivity of the Superheterodyne is, of course, also limited by the amount of static and interference in the air, but before discussing the effects of static on the Superheterodyne, let us first see why this receiver is the most sensitive, with the assumption that no static is present. In a recent theory propounded by Schrott, a definite limit to the sensitivity of the vacuum tube itself is given, whether used as detector or amplifier. This limit is determined by the noises within the tube itself. In the vacuum tube a stream of electrons flows from the filament to the plate. This stream is not always constant; there are many irregularities in its flow. While these irregularities cannot be heard in a head set connected in the plate circuit of the tube, they are nevertheless present and are quite objectionable when several stages of amplification are used. In other words, tube noises become quite an important factor in multi-tube sets. In the same way that static drowns out the signals when the signals are no stronger than the static, tube noises also drown out the signals when the signals are no stronger than the tube noises. Therefore, with no static present, the sensitivity of the ordinary radio set is limited by the tube noises. Adding amplification amplifies the noises in proportion to the signals and the sensitivity of the set is not increased. In order to increase the receiving range, it becomes necessary, therefore, to increase the signal strength before it enters the receiver and this is precisely what the Superheterodyne does.

In the Superheterodyne there is a vacuum tube oscillator. This oscillator is adjusted by means of the oscillator condenser so that it generates a radio frequency current of slightly different frequency from that of the incoming signals. The two currents interfere with each other and produce a heterodyne or beat note, of a frequency equal to the difference between the oscillator frequency and the signal frequency. This beat note is inaudible. In practice it usually has a frequency somewhere between 35 kilocycles and 150 kilocycles. As the two radio frequency currents are added to each other, the beat current is obviously much stronger than the incoming signal current. It is the beat current that actuates the first tube of the Superheterodyne, the first detector. While the strength of the signal may be below the level of the tube noises, in which case the signal could not be received on the ordinary set, by adding another radio frequency current to it so as to produce a much stronger beat note, the beat note, being stronger and above the level of the tube noises, can be detected and received by the Superheterodyne.

There is still another reason why the Superheterodyne is claimed the most sensitive. At broadcast wave-lengths it is

very difficult to employ more than two stages of radio frequency amplification. With two stages we have three dials to tune. Adding more stages would increase the number of dials and tuning would become very difficult. Furthermore, the amplification per stage, at broadcast wave-lengths, is not very great. If we simplify the tuning by using fixed transformers, the amplification is still less. In the Superheterodyne we only have two dials to tune, the antenna condenser dial, and the oscillator condenser dial. The beat note, or intermediate frequency, which is of much longer wave-length and corresponding lower frequency, can be amplified with as many stages of fixed transformer-coupled amplifiers as we desire. And by proper design the amplification per stage can be made much greater at the lower intermediate frequencies than at the higher broadcast frequencies.

If the sensitivity of the Superheterodyne, like that of all other receivers, is, in practice, limited by the amount of static and interference present, you may ask, therefore, what advantage is there in using a Superheterodyne? Off hand, it would seem that the receiving range can not be increased until some form of static eliminator is evolved. This is doubtless correct. But the main advantage of the Superheterodyne lies in the use of a small loop or indoor aerial. While extreme distances can be covered when using a Superheterodyne with an outdoor aerial, as a rule, equal distances can be covered when using the ordinary type of receiver. While more volume is obtained from the Superheterodyne, its receiving range is seldom greater. Using a loop aerial, just as many stations can be heard on the Superheterodyne as can be heard on any other type of receiver with an outdoor antenna. In addition, the directional characteristics of the loop reduce interference. Therefore, if you do not have space enough to erect an outside antenna, the Superheterodyne is the best set to use. With a build-in aerial it occupies a small space and is not only ideal for the average apartment, but makes an excellent portable set as well. It is without doubt the radio receiver of the future.

During the years 1923, '24 and '25 the Superheterodyne reached its highest state of popularity in this country. During this period many types of Superheterodyne receivers were developed. Some were doubtless very good, some questionable, and some of very little value. From the theoretical standpoint all are of great interest to the radio experimenter. In the following pages of this book, you will find constructional data and descriptions of practically all the Superheterodynes of interest developed in this country and abroad. While some of these receivers may give slightly better results than others, as a general rule, they are all about the same, provided, of course, that good parts are used in the construction. And here is where many radio experimenters found trouble. In the haste to supply the demand, many parts of questionable nature were placed on the market. Too little time was given to the design of the apparatus. Without a doubt every set described in this book can be improved upon. As an example, many of the circuits specify the use of a loud speaker plug and jack for the loop aerial, whereas we now know that this is very poor practice. A telephone plug and jack designed for audio frequency circuits cannot always be employed successfully for radio frequency circuits. The distributed capacities and dielectric losses are too high.

There are many other instances where slight improvements may be made. Two straight-line frequency condensers, mounted on one shaft, for the oscillator and tuner circuits are recommended. This not only simplifies tuning, but eliminates the objectionable feature of every Superheterodyne,—the reception of all stations on more than one setting of the oscillator dial.

But it is not the purpose of this introduction to design a Superheterodyne. You will find all the known types clearly explained in the following pages. It is up to you to make your own improvements and refinements if necessary, to suit your own particular fancy.

And last but not least there is a special supplement describing all issued patents involving the Superheterodyne and Superheterodyne principles. In view of the fact that the patent situation has considerable effect on the design of commercial Superheterodyne parts and sets, you will find this supplement very valuable. You now have before you a complete resumé of the entire Superheterodyne art.

Notes on the Superheterodyne

BY PROFESSOR GROVER IRA MITCHELL

This article is full of valuable information on the Superheterodyne. Of particular interest is the discussion of the relative merits of the air core and iron core types of intermediate wave radio frequency transformers.

THE many useful articles which have appeared in the radio periodicals within the past few months have demonstrated the widespread interest in the Superheterodyne method of reception. Many directions and specifications for building such receivers have been presented to the public with the result that the reader who has studied several of these articles, each of which stresses the wonderful results which are being obtained with the particular hook-up described, becomes confused and is at a loss to determine just which set he should build. The author of this article hopes to present some suggestion which will clear away much of this confusion.

give good volume from very distant stations. The last stage of audio frequency amplification would probably never be used except for very distant stations. Hard tubes of the U-201A or C-301A types are employed throughout. The "B" battery for the two detectors should furnish 45 volts for the plates while the "B" batteries for the amplifying tubes should be of about 90 volts, while 45 is generally sufficient on the oscillator. It will be noted that one set of "B" batteries is used for the two detector tubes, one set for the intermediate-wave amplifiers, and one set for the audio frequency amplifiers. This requires three distinct sets of "B" batteries.

finding much favor for the reason that it may be recharged. Storage "B" batteries are made in several sizes, ranging from about 700 milliampere capacity to about 5,000 milliamperes. Only the larger capacities should be used with the Superheterodyne.

When the special large sized dry-cell or the larger capacity storage "B" batteries are used, the same battery may supply the plate current for the oscillator and amplifier tubes. The detectors should be operated from a separate battery to secure best reception. This detector battery may be of ordinary size.

Superheterodyne with Antenna

Although the Superheterodyne is well adapted for use with a loop, it may be

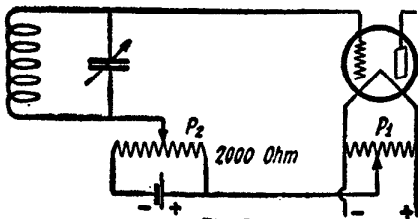

Fig. 2

Method of placing a negative bias on the grid of the first detector tube. This is a more satisfactory means than a grid condenser and leak.

Typical Superheterodyne Circuit

A typical Superheterodyne receiving circuit employing nine tubes is shown in Fig. 1. This circuit has four stages of intermediate-wave amplification preceded by the first detector and the oscillator and followed by the second detector with two stages of audio frequency amplification. It was designed to operate on a loop and has sufficient amplification to

The reason for using three sets of "B" batteries lies in the fact that the current drain on them for a receiving set having a large number of tubes is so great that if but one set of batteries was used to provide the plate current for all the tubes the life of the battery would be very short and the expense of replacing "B" batteries every few days would be prohibitive. By using the three sets of batteries, thus reducing the amount of current drawn from each set, the life of the three sets is about seven times as long as that of a single set used to supply all tubes.

"B" Batteries

Some of the manufacturers of the best known brands of "B" batteries are now making a special large size battery for use with the Superheterodyne circuit. The high milliampere capacity of these batteries enables them to provide the plate current for a large number of tubes and still have a life comparable to the ordinary sized battery used with the usual three or four tube set. The use of these large batteries is recommended. The storage type of "B" battery is

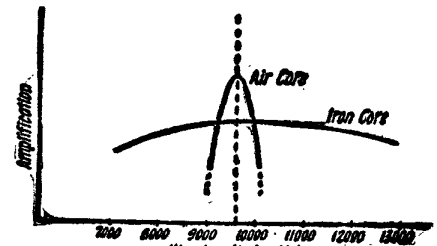

Fig. 3

Respective characteristic curves of an iron and an air core long wave radio frequency transformer.

used with an antenna. This is accomplished by using the coupler shown to the left of the dotted line in Fig. 1, which has an untuned primary. The secondary is tuned in the usual way by means of the variable condenser in the grid circuit of the first detector. A two-circuit jack may be inserted in the secondary circuit,

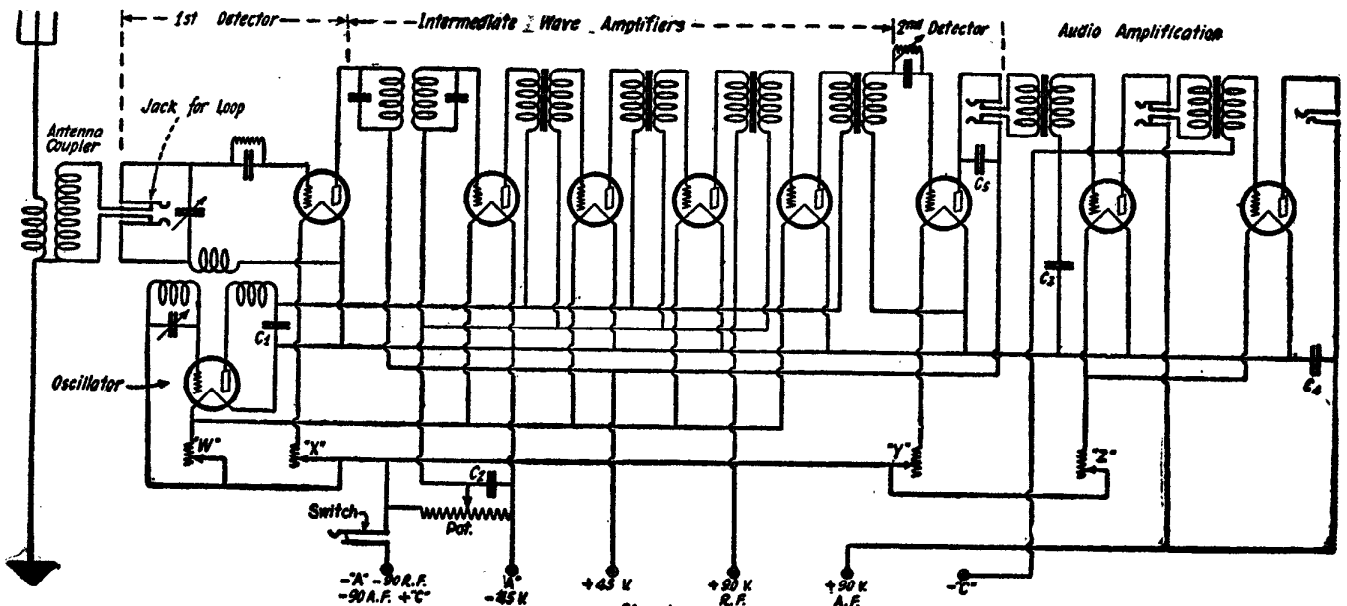

Fig. 1

Fig. 1. A typical nine tube Superheterodyne circuit employing four stages of intermediate wave radio frequency amplification and two audio frequency amplifiers. It works excellently with a loop aerial even when receiving from distant stations. Tubes of the UV-201A or C-301A type are employed throughout.

as shown, to permit the loop to be plugged in when wanted. When the plug connected to the loop is inserted in the jack, the inductance of the loop replaces the inductance of the secondary coil of the coupler.

Grid Condensers and Leaks

The diagram shows a grid condenser and leak in the grid circuits of each of the detector tubes. The grid condenser of the first detector rectifies the signal oscillations as well as the oscillations picked up by the pick-up coil from the oscillator circuit. The two sets of oscillations are heterodyned and sent to the amplifiers. The second detector again rectifies the oscillations and presents its rectified output to the audio frequency amplifiers.

Many who have built the Superheterodyne have found that the condenser and leak in the grid circuit of the first detector tube are very critical and have difficulty in securing the proper adjustment of these units.

The author has found that better results are obtained by placing a slight negative bias on the grid of the first detector and omitting the grid condenser and leak. The method shown in Fig. 2 was used. The grid return was connected to the center terminal of the potentiometer P2 placed across the "C" battery, an ordinary No. 6 dry cell such as is used for ringing door bells. P2 has about 2,000 ohms resistance so that the life of the "C" battery here is very long—one cell should last a season. The positive side of the battery was connected to the center terminal of a 400 ohm potentiometer P1 across the "A" battery. By adjusting the two potentiometers, using the one across the "C" battery as a vernier, any grid bias desired can be placed on the grid. Once the adjustment is correctly made, it is practically permanent. Reception is thus rendered more stable and one of the common operating difficulties of the circuit removed.

Air or Iron Core Transformers

There has been much discussion as to the use of air or iron core transformers for the intermediate stages. Some manufacturers offer the air core instrument with the statement that it is superior to the iron core type while others maintain loudly for the iron core type.

The answer to these conflicting statements lies in the design of the set. Some circuits work well with iron core transformers while other circuits seem to operate best with the air core type. Properly designed air core instruments are very sharp with reference to the wave bands to which they will respond and the iron core transformers will respond with almost uniform application to a relatively wide band of frequencies. This is illustrated by the amplification curves of Fig. 3, where curves for the air core and the iron core types of transformers are shown. It will be noted that the air core unit peaks very sharply while the iron core unit responds with approxi-

mately uniform amplification to a wave band between 6,000 and 12,000 meters.

For a receiving set having four stages of intermediate amplification, five transformers are required. At least one of these transformers—usually the first one—must be of the so-called filter type. The filter transformer selects the frequency at which the heterodyned signal is to be amplified and is very sharply tuned. Only waves of the length to which this transformer is tuned pass into the following stages. In Fig. 1, the filter transformer is of the air core type with each winding by-passed by a fixed condenser of such a capacity that both windings will respond with maximum amplification to the desired frequency and no other. This transformer with its shunt condensers will respond to, let us say, a wave of 9,600 meters as shown by the curve of Fig. 3. It matters little what type of transformer is used in the succeeding intermediate stages so long as they are able to amplify a wave of 9,600 meters with efficiency.

Although air core transformers in the succeeding stages are able to amplify at a relatively high ratio, they must all be sharply tuned to the same frequency as the filter—a condition which is somewhat hard to secure. If a set of perfectly matched transformers of the air core variety can be obtained, the amplification will be maximum and the receiving range of the set exceptional.

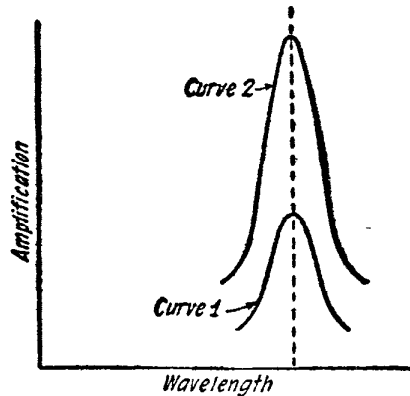

Fig. 4

Curve 1 is that of a sharply peaked air core transformer and curve 2 is that of four such transformers perfectly matched.

On the other hand, if iron core transformers are used in the succeeding stages, they will amplify very satisfactorily and will require no matching. This effect is shown in Figs. 4, 5, and 6. In Fig. 4 is shown the amplification curve produced by four sharply peaked air core transformers, all of which have the same amplification curve (shown at 1). Curve 2 is for the entire group, showing how the four perfectly matched transformers produce an extremely high amplification. Fig 5 shows four air core transformers which are not matched and whose amplification curves show that they are tuned to slightly different frequencies. The resulting amplification of the set is not as great as that of the perfectly matched unit of Fig. 4. Fig. 6 shows the amplification curves of a filter type air core transformer and the curves of three iron core transformers used as a group. The resulting amplification of the entire group is greater than the unmatched transformers of Fig. 5, but is not as great as the amplification for the group of perfectly matched units of Fig. 4.

It is because of the difficulty of obtaining perfectly matched air core transformers that many builders prefer to use one air core transformer as a filter and iron

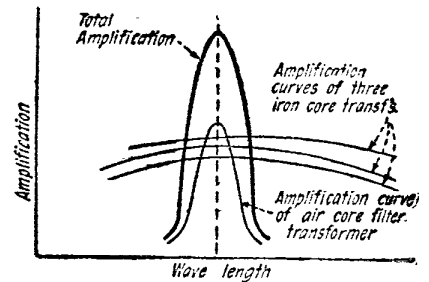

Fig. 6

The total amplification obtained by employing one air core filter transformer and four iron core transformers in the succeeding stages is shown by the highly peaked curve.

core transformers in the succeeding stages.

Rheostats

Each detector should have an individual filament control rheostat. The oscillator tube and the tubes of the intermediate amplifiers may be controlled by means of one rheostat and the audio frequency stages by another rheostat. Individual rheostats on the detector tubes permit these tubes to be adjusted there for best action. Individual rheostats on the other tubes offer no advantage.

Grid Bias

Most Superheterodyne circuits use a potentiometer the center terminal of which is connected to the grid returns of the intermediate amplifier tubes to place a slightly positive bias on the grids of these tubes to prevent oscillation. The use of the potentiometer effectually prevents oscillations in intermediate stages but at a sacrifice of several advantages which would be secured if oscillations could be prevented through other methods. It is well known that a positive grid potential greatly increases the plate current and thus places a greater load on the "B" batteries. Much work is being done by experimenters and manufacturers in an effort to devise a way to prevent oscillations in the intermediate stages without the use of the potentiometer. One method is a negative feedback arrangement such as is used in the Neurodyne circuit. If the oscillations can be prevented, a negative bias can be applied to the grids of these tubes with a great saving in "B" battery current, and better amplifier action.

One method of preventing oscillation in the intermediate stages is shown in Fig. 7. Here the plate and grid of each tube are coupled by the condenser C and the resistance R. The condenser is the ordinary mica type of about .00025 mfd. capacity. The resistance R should be of the pencil mark variety and should be adjusted until oscillations just cease. A "C" battery may then be used to bias the intermediate stages.

Effect of "C" Battery

The use of the "C" battery effects a saving in "B" battery current ranging (Continued on page 8)

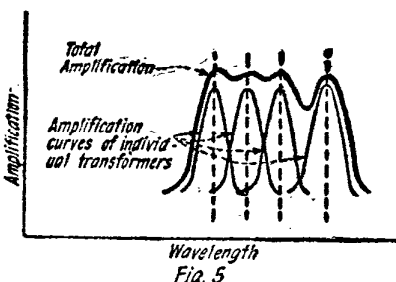

Fig. 5

The curves of four air core transformers not matched, each being tuned to a slightly different frequency.

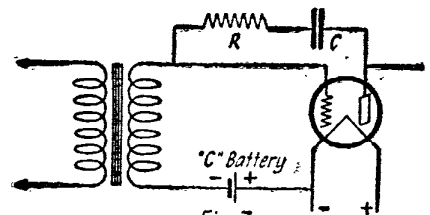

Fig. 7

A method of preventing oscillation in the intermediate stages by the utilization of resistance and capacity from plate to grid members of each tube.

Superheterodyne Circuits

A Comparison and Brief Explanation of the Better-Known Types of Superheterodyne Receivers

THE experimenter who is thoroughly interested in radio should not fail to investigate the Superheterodyne method of reception. Actual tests have proved that the Superheterodyne is by far the most sensitive receiver in existence today. With a loop, aerial reception may be obtained from coast to coast of the United States. But with all this extreme sensitivity, reports indicate that only about 20 per cent of those who build this receiver attain what might be called normal reception. A little better understanding of the theory and operation of the Superheterodyne is necessary

parts: namely, the frequency changer, the intermediate frequency amplifier, the detector, and the audio frequency amplifier. The frequency changer consists of an oscillator, tube 1, Fig. 1 and a detector, tube 2. The purpose of the oscillator is to heterodyne the radio currents received by the loop, thus setting up a beat note of a much lower frequency than either the signal frequency or the oscillator frequency. The beat note frequency is equal to the difference between the oscillator frequency and the signal frequency, indicating that the oscillator may be adjusted to a frequency

The data for building this set is as follows: The loop aerial should be of standard design for broadcast reception. It may be tapped if desired for use for amateur or short wave reception. It is shunted by a .0005 mfd. variable condenser. The oscillator coils may be wound on a three-inch tube, spaced one-half inch from another. For broadcast reception coil L-1 should have 55 turns when shunted by a .0005 mfd. condenser. For amateur reception it may have 20 turns. Coil L-2 should have 30 turns for broadcast reception and for amateur reception 10 turns wound in the same

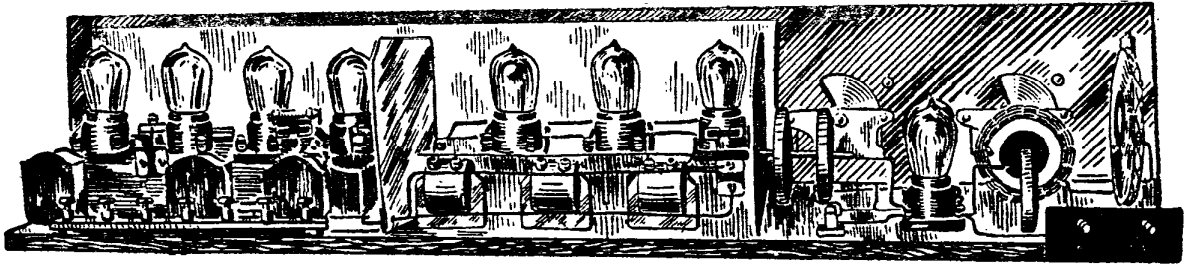

Illustrations by Courtesy of *The Experimenter* (New York)

Rear view of a typical 9-tube Superheterodyne employing the standard circuit, Fig. 1, with push-pull audio amplification. Note the metal shields between the audio and intermediate amplifiers.

in order to produce maximum results. We are, therefore, showing five Superheterodyne circuits and will point out the main features of each so that the experimenter can try them out for himself and make his own investigation. Actual constructional data is not given. In trying out these circuits the experimenter should mount the apparatus on a board with plenty of room for connections and binding posts.

Writing in *The Experimenter*, Clyde J. Fitch presents some interesting points concerning various types of Superheterodyne receivers and gives the schematic diagrams for five of the more important arrangements. The author is peculiarly well-fitted to talk on the subject of Superheterodynes, having designed what is perhaps the simplest practical version of this receiver. It is gratifying to note that he gives his views from a purely technical and impartial standpoint, not giving way to the prevalent desire to advance one type while belittling the value of the others. After going over this brief article the reader may be better qualified to judge the merits of the particular type being used. The article continues as follows:

Standard Superheterodyne Circuit

Fig. 1 shows a standard Superheterodyne circuit. It is well to start with this circuit as a basis to work on and make all changes and improvements from it. In building this circuit it is well to use a loop aerial exclusively, as when properly constructed the set with a loop will give as good results as any other radio set will give with an outdoor aerial. By using a loop aerial, the comparative efficiency of the set is more easily observed.

We will not go deeply into the theory of the Superheterodyne as this has been covered elsewhere. It suffices to say that this receiver is divided into four

above or below the signal frequency and consequently all stations will be received on two settings of the oscillator condenser dial.

The beat frequency or intermediate frequency may lie anywhere between the incoming radio frequency and the audio frequency at the output. In practice it usually is at a frequency having a wavelength between 1,000 meters and 10,000 meters (300,000 to 30,000 cycles). Excellent results are obtained at a frequency of 50,000 cycles (6,000 meters), and this frequency may be chosen as a basis to work on. The intermediate frequency amplifier consisting of tubes 3, 4 and 5 must be adjusted to amplify at this intermediate frequency of 50,000 cycles.

The intermediate frequency transformers are usually of the iron core type. In Fig. 1 we show the method used in the standard Superheterodyne. The first three transformers are designed to operate over a wide range of wave-lengths from about 2,000 to 10,000 meters. But as sharp tuning is required for this amplifier in order to obtain selectivity, some form of filter coupler is required that will by-pass currents of one frequency only. This consists of a transformer made up of two honeycomb coils, one of which is sharply tuned by a variable condenser. This coil is connected in the grid circuit of the detector tube 6. Tubes 7 and 8 are audio frequency amplifiers and as the connections are standard, they need not be described here. Note that a variable resistance (R) is connected across the second transformer to control the volume and prevent or reduce circuit noises. A .006 mfd. condenser is absolutely necessary across the primary of the first audio transformer to by-pass the powerful intermediate frequency currents. Low ratio transformers of about 3 to 1 give best results in both audio stages.

direction as coil L-1. Coil L-3 is the pickup coil and consists of about 6 turns. No. 22 DCC wire may be used for all these coils.

The intermediate transformers may be obtained from any reliable radio dealer. There are many types on the market. The filter coupler as shown consists of a 300-turn honeycomb coil and a 600-turn honeycomb coil shunted by a .0005 variable condenser. The constants of the other parts are indicated in the drawing.

Model L-2 Ultradyne

As an improvement over the standard Superheterodyne we are showing in Fig. 2 the circuit diagram of the popular eight-tube Ultradyne receiver. This receiver is of simplified construction in that it employs Amperites for the filament current control instead of the usual filament rheostats. There are eight tubes. The oscillator, tube 1, may be constructed according to the instructions given in connection with Fig. 1. The circuit shows two coils of 55 turns and 45 turns, the 55 turn coil being shunted by a .0005 mfd. condenser. The other constants of the circuits are given. Note the 20-turn and 30-turn coils in the modulator, tube 2, for regeneration. Any small variocoupler may be used for this.

In trying these circuits it may be well for the experimenter to build an intermediate amplifier, detector, and audio amplifier in one unit so that the unit may be used for all experiments.

Second Harmonic Superheterodyne

Another improvement on the standard Superheterodyne is depicted in Fig. 3 which shows the circuit diagram of the six-tube Superheterodyne sold by the Radio Corporation of America. Due to lack of information on this receiver we cannot give constructional data for building the set. The action may be

Five of the Latest Superheterodynes

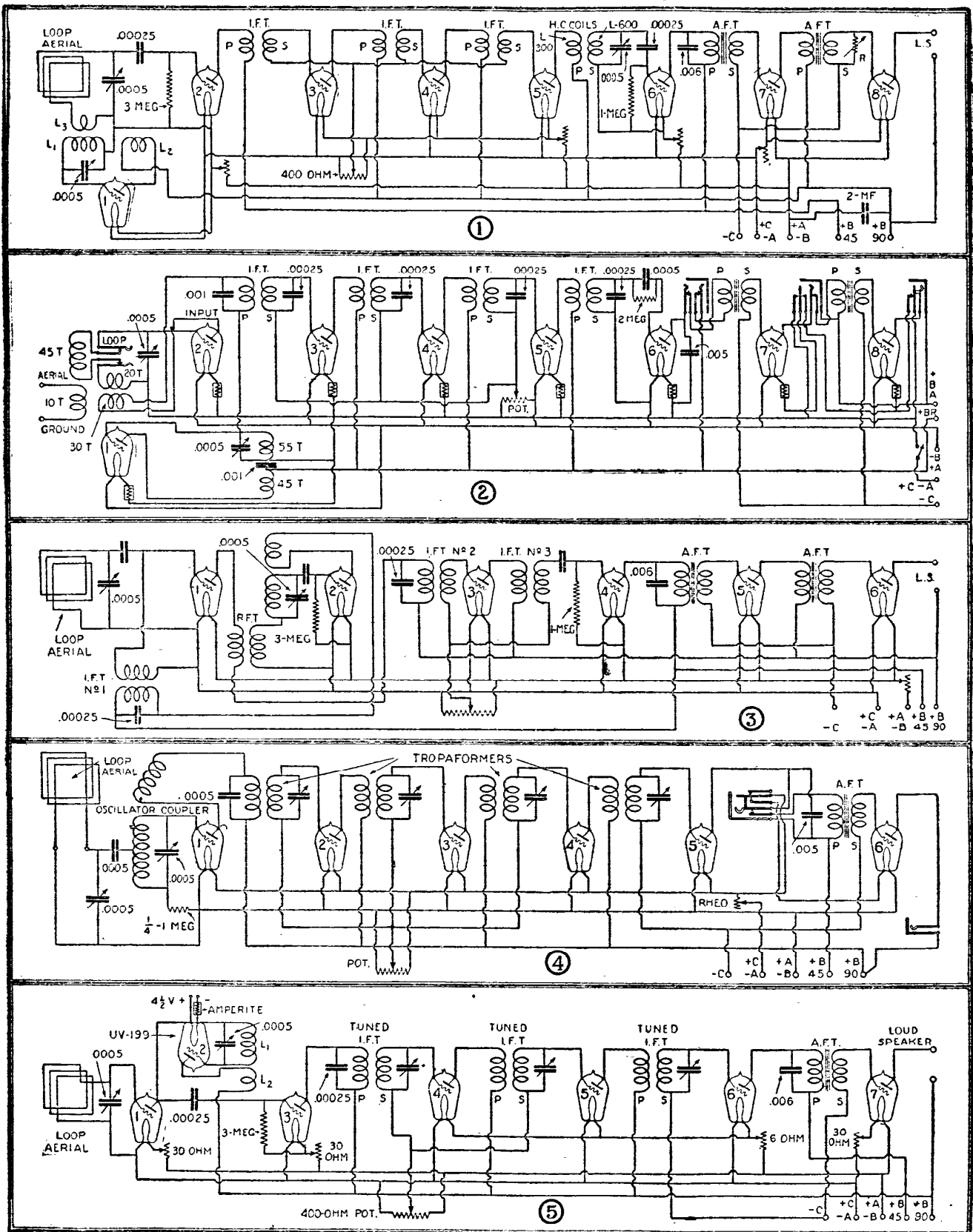

Fig. 1.—The standard 3-tube Superheterodyne using transformer coupled amplifiers. Fig. 2.—The L-2 Ultradyne using the modulation system and regeneration. Fig. 3.—The 6-tube second harmonic Superheterodyne. Fig. 4.—The 6-tube Tropadyne using tuned intermediate transformers. Fig. 5.—A special 7-tube Superheterodyne.

described with reference to the diagram and will show experimenters the steps taken by radio engineers for improving the super.

Tube 1 is used as a short wave radio frequency amplifier. It is connected to the loop aerial and the tuning condenser. In the plate circuit of this tube we have a fixed radio frequency transformer designed to cover the entire broadcast range from 200 to 600 meters. This transformer no doubt is of the iron core type and has a secondary winding of only a few turns. The secondary is connected to the grid circuit of the oscillator, tube 2. The oscillator coils and condensers are proportioned so as to give a frequency of half the signal frequency, so that the second harmonic of the oscillator frequency heterodynes the signal frequency. In other words, the oscillator should be designed to cover a wave-length range of 400 to 1,200 meters. The grid condenser and leak shown in this circuit may be omitted.

The plate circuit of the oscillator tube feeds into the intermediate frequency transformer No. 1 which is reflexed back into the first tube as shown. The secondary is connected in parallel with the loop. Therefore, tube 1 amplifies both signal frequency and intermediate frequency. Intermediate frequency transformer No. 2 is connected in the plate circuit of tube 1 and feeds into tube 3. The remaining part of the circuit is

standard. The complete circuit gives the equivalent of one stage of short wave R.F. amplification, detector, oscillator, two stages of intermediate amplification, detector, and two stages of audio amplification.

The Tropadyne Receiver

Another simple six-tube Superheterodyne circuit is shown in Fig. 4. In this circuit the first detector and oscillator are combined in the one tube by connecting the loop circuit between the filament and nodal point or center tap of the oscillator circuit. This eliminates one tube from the circuit, and by using special tuned intermediate transformers, the volume is increased to such a point that only one stage of audio amplification is required, with the result that six tubes do the work of eight.

The oscillator coupler may be any vario-coupler now in the market, and connections are made to the center turn of the secondary coil as shown. Fifty-five turns on the three-inch tube shunted by a .0005 mfd. condenser are suitable for broadcast reception. The constants of the circuit are given and need not be mentioned again. The only critical part of the whole circuit is the grid leak which preferably should be adjustable.

Special Superheterodyne

A new Superheterodyne circuit which

has never before appeared in print is shown in Fig. 5. This circuit is given merely for experimenters to investigate as to the best of the writer's knowledge it has never been hooked up.

We are all familiar with resistance coupled amplifiers, using a vacuum tube as the coupling resistance. In this circuit we use a UV-199 tube for this purpose and light its filament by a separate small flashlight battery. This is tube 2 in the diagram. An Amperite is recommended in the filament circuit. In addition to acting as a coupling resistance in a short wave radio frequency amplifier, we connect our oscillator coil to this tube and make it act as an oscillator also. Thus in tube 1 we have a short wave amplifier using tube 2 as a coupling resistance, which also is an oscillator and heterodynes the received currents. Both oscillator frequency, signal frequency, and the difference between the two or beat frequency are impressed on the grid of the detector, tube 3, which detects the intermediate frequency. This, of course, is amplified by tubes 4 and 5, and the audio currents are detected by tube 6 and amplified by tube 7. In both this circuit and the Tropadyne circuit, Fig. 4, no grid condenser and grid leak is used for the second detector. Far better results are obtained as regards quality and volume when using a "C" battery for the second detector, instead of the grid condenser and grid leak.

Notes on the Superheterodyne

(Continued from page 5)

from 100 to 300 per cent. Audio frequency stages are especially benefited by the use of the "C" battery.

Although the "C" battery reduces the amount of current in the plate circuits of the tubes, it does not cause a reduction in the strength of signals when properly used, but rather a slight increase with added signal clarity.

The sound produced by the head set or loud speaker does not depend upon the total amount of current flowing through their windings, but on the amount of change or variation in this current. The "C" battery reduces the amount of current supplied by the "B" batteries but does not reduce the variations. This is effectually shown in Fig. 8 where the upper curve shows the plate current without the use of a "C" battery both when no signal is being received and when a signal is coming in. The lower curve shows the plate current when a "C" battery of the proper potential is used under the same conditions. The variations in the plate current at the right-hand end of the curves are what produces the sound and it is seen that the signal strength in each case is

the same. The "B" battery will last about three times as long under the conditions represented by the lower curve.

Size of Set

One of the chief objections to building the Superheterodyne has been the large size of the set and the excessive amount of labor required for its assembly. In the large number of units which make it up, mistakes in connecting are the rule

rather than the exception. Once such a mistake has been made, it is very difficult for the builder to locate the fault. Then, too, there is the possibility that the parts are not adapted for use together. The builder should therefore buy sets of parts which have been tested by the manufacturers. This will give assurance that the various parts are adapted to work together and will insure a set which is capable of giving the best results.

Popularity

That the popularity enjoyed by the Superheterodyne is well deserved is instanced by the remarkable long distance receiving records being made in all parts of the United States with it. Many radio fans say it is the ultimate set for the present state of the radio art. It is the opinion of many radio authorities that no advancement beyond the Superheterodyne will be made until there is some revolutionary invention or discovery which will completely upset our present conceptions of radio communication—an event which seems difficult to realize but which is not beyond the limits of probability.

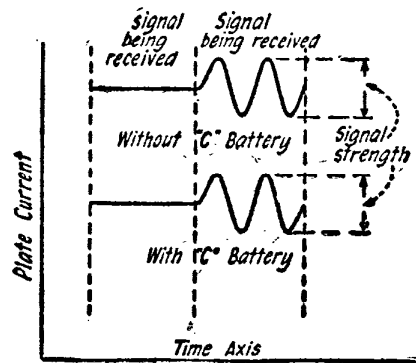

Fig. 8

By comparing these two curves it will be seen that the use of a "C" battery cuts down the plate current but does not detract from the signal strength.

A 3000-Mile Superheterodyne

By R. A. STUART-FREY,
Paris, France

In the illustration below the author is shown operating his receiver, a Superheterodyne, which is described in this article.

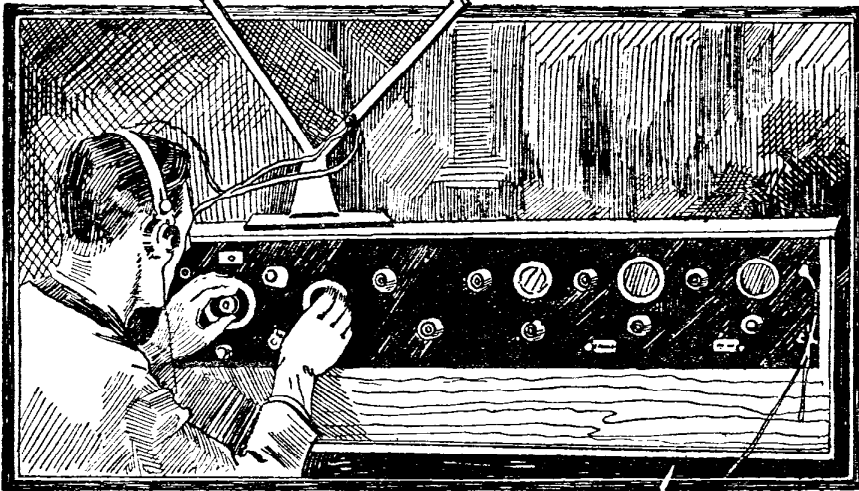

That consistent long-distance reception of broadcast stations can be accomplished by ordinary radio fans is attested by the experiences of this writer. Mr. Stuart-Frey regularly receives in France concerts from WRNY, the RADIO NEWS broadcast station, on the receiver described here.

local strength, at times sufficient to work a loud speaker. At the time fading was bad. The result of adding the radio frequency tube before the detector was very marked, as regards the signals received, and also the absence of much interference from high-powered arc stations. Sharper tuning also resulted.

As the winter months approached, I received WRNY at loud speaker strength for half an hour until fading set in. This fading was 40 seconds in duration. Atmospherics were absent.

Reception Conditions in Paris

Here in Paris, long-distance reception is difficult, owing to the fact that the town lies in a valley and also suffers from the shielding effects of tall buildings. Atmospheric conditions here are not good at any time, and it is only by using a loop aerial that long-distance reception can be carried out without serious interference from the high-powered stations and atmospherics.

The chief cause of interference is Eiffel Tower, FL, transmitting on 2,600 meters with 25 k.w. in the aerial. This station jams almost everything.

As a whole, I can receive WRNY fairly regularly, together with other American stations, if conditions are fair.

The receiver I mentioned above is of my own design and very efficient. Once the transformers have been tuned, the controls are reduced to the main dials.

The panel is 40 inches long by 8 inches wide. This panel carries the two variable condensers, rheostat, potentiometer, variocoupler for the oscillator circuit and a small two-way switch for placing the variable condenser in parallel or series with the loop, for long or short wavelengths.

The intermediate transformers have adjustable iron cores. This enables the amplifier to be stabilized and prevents distortion which might take place from the cutting off of the side bands by the very sharp tuning obtained with these transformers.

The construction of the transformers is as follows:

UPON the opening night of WRNY I listened for it, but, on account of very unfavorable conditions prevailing at that time, I found it impossible to pick up the station. Later, after many unsuccessful attempts, I succeeded in locating WRNY at about 1:30 A. M., Greenwich Mean Time. Conditions were bad, atmospherics and fading being very prevalent. The signals were just audible with telephones. At the time I was using an 8-tube Superheterodyne, comprising first detector, oscillator, three intermediate frequency, second detector and two audio frequency, in conjunction with a two-foot loop aerial. Afterwards, I experimented with a small indoor aerial and also an outdoor aerial. These aeri-als brought in WRNY with greater strength, but the signals were drowned by atmospherics, mush, etc., from high-powered arc stations.

After considering the matter carefully, I decided to change the circuit and to utilize the Tropadyne system for the detector and oscillator, placing a radio frequency tube in front of the combined detector and oscillator. In so placing this radio frequency tube, I was confronted with an extra control, which meant complicated tuning. I then decided to use an aperiodic air-core transformer, but so designed as to cover a small wave-band. It was necessary to

construct a number of these transformers, the complete series covering from 100 to 600 meters. To make these transformers easily interchangeable, I mount-

RADIO NEWS takes pleasure in presenting herewith a constructionally descriptive article concerning a Superheterodyne which has been used for the past half year to bring in station WRNY in Paris. Several novelties are incorporated in the design of the set, one of the most important of which is the use of adjustable iron cores in the intermediate frequency transformers.

Complete details are given in the article for the construction of the set. It employs the Tropadyne system of heterodyning and one radio frequency tube before the detector-oscillator for increasing sensitivity and selectivity. Many fans in congested centers would do well to copy the design.—EDITOR.

ed them on tube bases, so that they could be plugged into a standard French tube socket.

After constructing this apparatus and using the same two-foot loop aerial, I succeeded in pulling in WRNY with

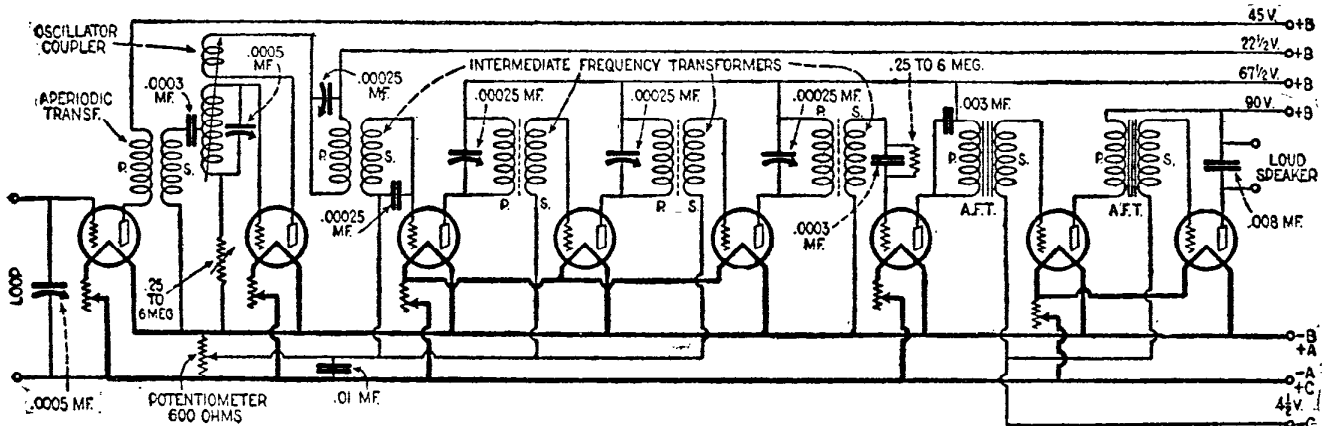

The circuit diagram of the super-heterodyne receiver which receives WRNY regularly on a loop in France. The circuit has several new points about it in connection with the design of the intermediate transformers, which are described and illustrated on the following page.

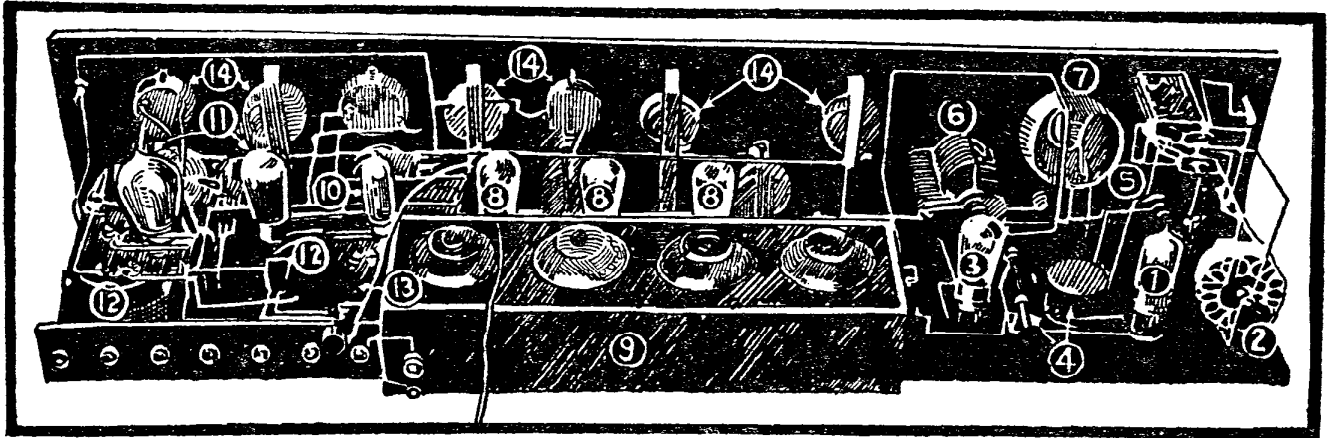

The receiver is divided into units: 1, first detector; 2, oscillator coils; 3, oscillator; 4, grid leak and condenser; 5, tuning condenser; 6, oscillator condenser; 7, coupling and pick-up coil; 8, intermediate frequency amplifiers; 9, intermediate transformers; 10, second detector; 11, A.F. amplifiers; 12, A.F. transformers; 13, grid leak; 14 rheostats.

A piece of hard rubber rod $1\frac{1}{4}$ inches in diameter is obtained and cut into lengths of 2 inches. Four of these are required. The rod is then placed in a lathe and seven slots, each $\frac{1}{8}$ inch wide and about $\frac{1}{8}$ inch apart, are cut. The first slot is $\frac{3}{8}$ inch deep and the second $\frac{1}{4}$ inch deep. Continue this, cutting each alternate slot $\frac{1}{4}$ inch deep, until the seven slots are cut. (See Fig. 1.) The deep slots are for the secondary windings. A $\frac{1}{4}$ -inch hole is now drilled in the center of the transformer to receive the iron core. In one end four holes are drilled and tapped and into them are screwed four tube bases, so arranged that they plug into a standard French tube socket.

Now the transformer is ready for winding. This may be done on a lathe or by hand. Into the first slot wind 150 turns of No. 38 S.S.C. wire. When this is finished continue the winding into the third slot, and so on, until you have 150 turns in each deep slot, making 600 turns in all. Into the remaining three slots wind 100 turns per slot of No. 38 S.S.C. wire, making a total of 300 turns in all. The ends are now soldered to the tube bases, as shown in the diagram, the beginning of the primary winding going to the B+ and the beginning of the secondary winding to A-, or the potentiometer center arm.

On the top of one of the transformers a fixed condenser of .00025 mf. is screwed. This condenser is shunted across the secondary winding. The transformer is now the input or filter transformer.

Four variable condensers of a capacity of .00025 mfd. are now obtained. These condensers are mounted on a piece of hard rubber which is, in turn, mounted on a box. On one side of the box are mounted four tube sockets, into which the transformers will be plugged. (See diagram.) All the plate and grid leads

are brought to terminals which pass through hard rubber bushings, also the leads which go to the potentiometer center arm. The "B" and "A" positive leads are brought out to terminals on opposite sides of the box. The condensers are connected across the primary windings of the transformers. The box is now

before the detector are constructed as follows:

Fig. 1 gives a sectional view of a spool made from hard rubber discs. The trans-

INTERMEDIATE TRANSFORMERS

PRIMARY-300 TURNS OF No. 42 S.S.C. WIRE, 100 TURNS PER SLOT.
SECONDARY-600 TURNS OF No. 42 S.S.C. WIRE, 150 TURNS PER SLOT.
PRIMARY TUNED WITH VARIABLE CONDENSER .00025 MF. (MICA TYPE)

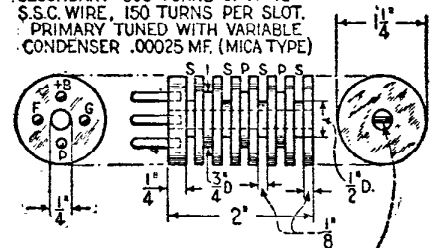

ADJUSTABLE IRON CORE
3 PIECES SILICON STEEL
2" LONG X $\frac{1}{4}$ " WIDE X .003" TH.

The 42 S.W.G. indicated above equals 38 B & S gauge, as given in the text.

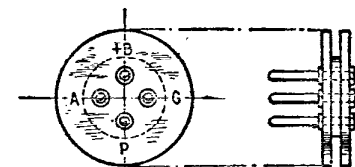

APERIODIC TRANSFORMER

Fig. 1. The design of the intermediate transformers is shown in this illustration. It is possible for any radio fan to copy this design.

NOTE

This Superheterodyne receiver employs the very popular and efficient Tropadyne system, which was fully described in the August and November 1924 issues of RADIO NEWS magazine.

Those who would rather purchase the various intermediate frequency transformers necessary in this receiver, can obtain them under the trade name of "Tropafomers"; for these intermediate frequency transformers have exactly similar characteristics to that described in this article.

mounted behind the tube sockets and connected up in the usual way. By placing the transformers in a box all leads are hidden from view. A small hole is drilled opposite each transformer, so that the iron core may be inserted after the transformers have been tuned.

The aperiodic transformers used be-

No. of Turns	B & S Wire	Inner Diam.	Outer Diam.	Width of Slot	Wave-Length
30	34 S.S.C.	$1\frac{1}{4}$ "	2"	$\frac{1}{2}$ "	190-240
45	"	"	$2\frac{1}{4}$ "	"	240-300
80	"	"	$2\frac{1}{2}$ "	"	300-400
150	"	"	$2\frac{3}{4}$ "	"	400-600
200	"	"	3"	"	550-750

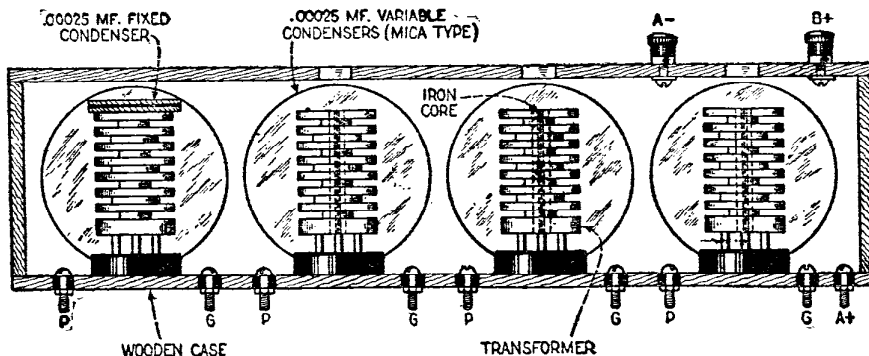

The layout of the intermediate transformers and the condensers which tune them. The transformers are mounted below the condensers, which are of the variable mica dielectric type. The whole is then enclosed in a wooden casing to keep out all dust and dirt.

formers are wound with No. 34 S.S.C. wire, the primary and secondary windings being wound in the same direction. The primary is wound on first and covered with a thin layer of silk thread or insulating tape.

The secondary winding is then wound on top of it. Then the ends are soldered on the tube bases, as shown in the diagram. The beginning of the primary winding goes to the "B" positive and the beginning of the secondary winding to "A" positive. The number of turns given above is for primary and secondary, as each winding has the same number of turns:

The oscillator coupler is made from a 180-degree variocoupler. The stator consists of 47 turns of No. 24 D.S.C. wire (Continued on page 34)

An Improved Laboratory Superheterodyne

BY ERNEST R. PFAFF

Here is another Superheterodyne, which incorporates two rather novel ideas. One is the use of plug-in inductances and the other is the connection of the oscillator—first detector.

WITH the advent of a new radio season, bringing with it receiving conditions differing immeasurably from those encountered last year, the time seems most opportune to present a description of an improved Superheterodyne, designed to meet existing American or foreign broadcast conditions.

Aside from the increased number of broadcasters, and their increased power, there is the extension of wave-length ranges to be considered. Last year 250 meters was the low limit in practical use. Today it is 300,000 cycles higher, or 200 meters. Few of last year's receivers will efficiently reach this new low limit. Rebroadcasting brings in an even lower limit, so that our really practical receiver must go down to 50 meters and up to 550. If it is desired to listen to the high-powered European stations, then this range must be extended to 2700 meters.

Specifications

Possibly the first features to strike the eye are the interchangeable oscillator and antenna coil system. Plug-in coils are used in each circuit, arranged to cover the desired wave-length range. Three coils are used in both the oscillator and antenna circuits to tune from 50 to 550 meters. They are wound upon moulded bakelite forms.

If a loop is to be used, it is merely necessary to remove the antenna coil from its six-contact socket and connect the loop to three binding posts on the socket. For different wave-length ranges, both oscillator and antenna coils are merely plugged in or out, exactly as a tube would be. The oscillator coupling coil is connected in the filament return of the first detector rather than in the grid lead, which gives somewhat greater selectivity, and permits of greater efficiency at short wave-lengths.

Straight-line frequency condensers are recommended, in order that maximum ease of tuning may be experienced upon the short waves.

Vernier dials may or may not be used, as desired, but it will be found somewhat difficult to tune the receiver without them. Some friction type should be

used if it is desired to take advantage of the single-control feature, which will be considered further on.

Most intermediate amplifying transformers and filters are carefully tuned at the factory to exactly the same operating frequency, the filter being provided with a measured tuning condenser of exactly the correct value. The iron-core type is recommended. With controlled regeneration these will give a great amplification as it is possible to obtain. The over-all amplification curve of the two-stage amplifier is very similar to that of an extremely good band-pass filter as used in carrier telephone work. This means that a band only wide enough to pass the desired signal receives amplification. In this particular amplifier, the width of the band may be varied by the

the first detector would be too large for good results on low waves. Further, regeneration control and selectivity improved slightly through the use of a grid bias.

The positioning of the oscillator coupling coil is evident from a reference to the circuit. It will also be noticed that only the oscillator grid circuit is tuned, thus bringing one side of the oscillator tuning condenser at ground potential, and eliminating any tendency toward hand capacity effect.

The mechanical features of the set are quite simple. Views are shown of the shielded model. An aluminum sub-base, together with an aluminum panel shield is used. If the back, ends, and top of the cabinet in which the set is placed are also shielded, the selectivity obtain-

A front panel view of the new improved Superheterodyne. Note the simplicity of controls.

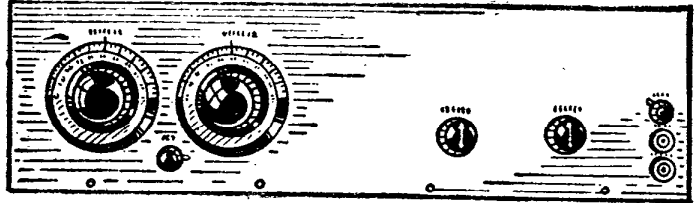

volume control, from a width so great that selectivity and amplification are poor, up through a good operating condition, and on to a point where the frequency band passed is so narrow that little or nothing but the low notes of a station come through.

The audio amplifier suggested employs 3½:1 transformers. The size of the base-board is great enough to permit the addition of an extra tube, so that a three-stage resistance coupled amplifier might be used, or a three-stage choke coupled amplifier, to be selected by the individual builder.

The circuit is not at all new, except for the use of a grid bias upon both detector tubes rather than the grid condenser and leak generally used. The reason for this is primarily one of convenience, since practically the sensitivity for either system appears substantially equal. However, a grid condenser and leak suited to broadcast reception with

able will be remarkable. The choice between the shielded and unshielded methods of construction is quite simple. If the receiver is less than a mile from a broadcaster, then the shielded model should be selected, by all means. Though its assembly may appear a task for a tinsmith, it is really quite simple, since the aluminum works as easily as bakelite, and may be obtained cut to size. The unshielded model is entirely satisfactory for use outside a one-mile radius of a powerful broadcaster.

Results

Generally, writers of constructional articles feel that their work is incomplete without a glowing tale of the wonderful results obtained from their particular circuit. The writer is no exception, nor is it assumed that the reader would wish to remain uninformed of what may be expected from the sets. During August a test was run in a building adjacent to

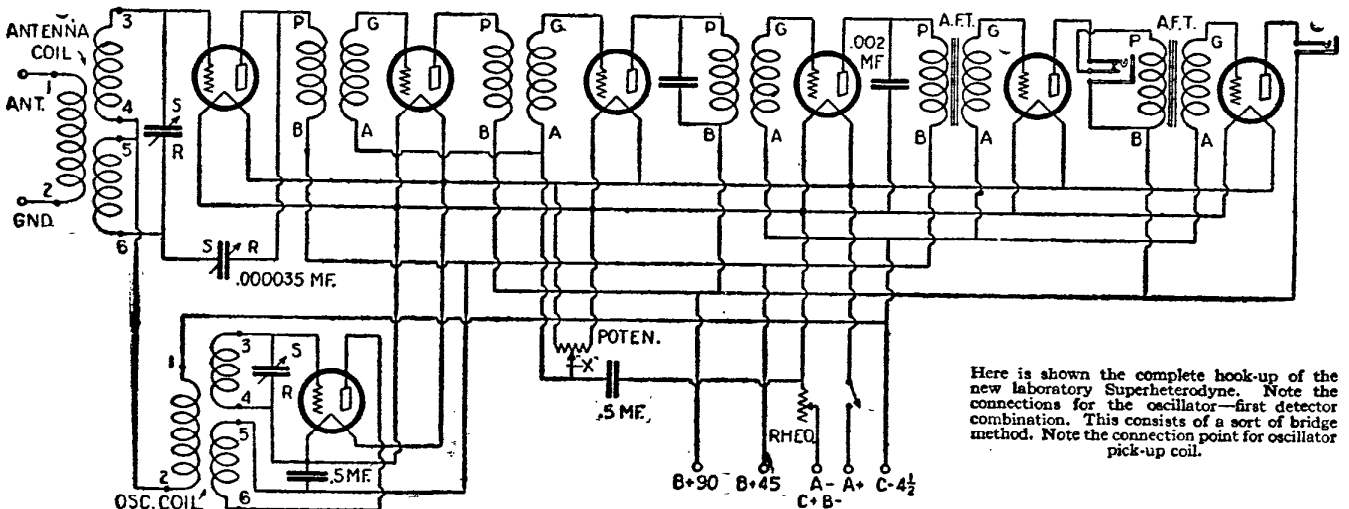

Here is shown the complete hook-up of the new laboratory Superheterodyne. Note the connections for the oscillator—first detector combination. This consists of a sort of bridge method. Note the connection point for oscillator pick-up coil.

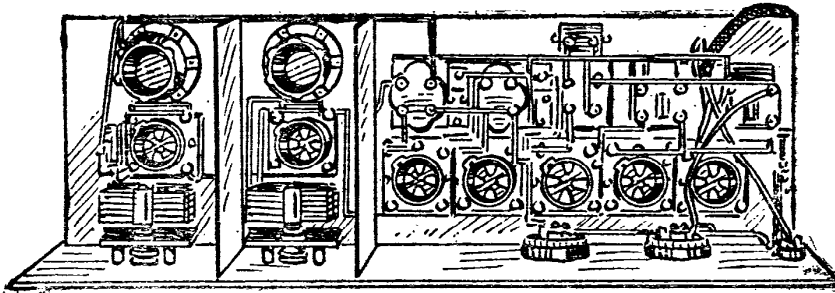

This view of the new Superheterodyne shows the parts with two of the inductances in place in the receptacles. It also shows the shielding.

a new steel frame hotel in the Chicago loop district. Some twenty out-of-town stations were logged between nine and twelve o'clock including coast stations. More were heard, but could not be logged, due to terrific static and elevated railway interference—located less than 75 feet away. However, the important fact is that within a radius of but a few miles, some ten local stations were operating—three of them not half a mile distant. Yet the selectivity was such that no trouble was experienced in working.

Parts for this set should be selected which will co-ordinate properly, and are of equal quality, since the results obtainable are dependent, in a large measure, upon the use of the parts selected.

A list of material is given in the accompanying box.

- | | |
|---|-----------------------------------------------------------|
| 2 | .00035 SLF condensers. |
| 2 | 4" moulded dials, vernier preferably. |
| 1 | 6-ohm rheostat. |
| 1 | 200- to 400-ohm potentiometer. |
| 1 | 2-Spring jack. |
| 1 | 1-Spring jack. |
| 2 | Charted intermediate transformers. |
| 1 | Tuned filter with condenser. |
| 7 | Spring sockets, UX or UV. |
| 2 | 3½:1 audio transformers. |
| 1 | On-off switch. |
| 3 | .5 mf. bypass condensers. |
| 1 | .002 bypass condenser. |
| 1 | .000035 mf. balancing condenser. |
| 1 | 7x24x⅝" bakelite panel. |
| 1 | 7½x23 oak or aluminum sub-base. |
| 2 | Coil sockets, screws, lugs, nuts, solder, spaghetti, etc. |

If the completely shielded model is to be built, additional aluminum shielding will be required. The sub-base should be No. 8 gauge, while the balance may be No. 20 gauge, cut to fit the desired cabinet.

No specifications for the oscillator coils have been given. It is possible to use standard six-contact forms for these coils, which can be procured on the market, as these will plug into the sockets listed very nicely and are completely provided with hardware. They may be procured wound or unwound, as desired. The winding specifications are given below.

For the antenna coil, the stator tube should be wound with two equal sections, and the rotor tube with one section, split for the rotor bearings, as listed:

190—550 meters:	
Stator	43 turns per coil
Rotor	40 turns per coil
90—210 meters:	
Stator	16 turns per coil
Rotor	10 turns per coil

50—110 meters:	
Stator	7 turns per coil
Rotor	6 turns per coil

For the oscillator system, the top stator coil is much larger than the bottom one, the larger being used in the grid circuit, the smaller in the plate circuit. For the rotor and pick-up coil, the winding specifications are as follows:

190—550 meters:	
Large stator	84 turns
Small stator	25 turns
Rotor	40 turns
90—210 meters:	
Large stator	32 turns
Small stator	14 turns
Rotor	10 turns
50—110 meters:	
Large stator	14 turns
Small stator	10 turns
Rotor	6 turns

In all cases, the stators are wound as one continuous winding, the top end being No. 3, the bottom end of this winding being No. 4, the top end of the next winding being No. 5, and the bottom end of this winding being No. 6. The rotor numbers are 1 and 2. These coils may be clipped in at will and adjusted to any desired position. After being once set, they need never be disturbed.

Any standard type of tube may be employed. The writer prefers UX-199 tubes up to the second audio stage, with UX-120 for the last stage. UX-201As, with the last stage UX-112 will give slightly greater handling capacity, higher "B" battery consumption and, possibly, a little more volume.

Construction

Should the aluminum shield be used, holes must be drilled in it to correspond with those in the panel, but so oversized that no instrument will short on it, except the oscillator condenser, the frame of which goes to the negative filament line, which is also the shield.

If the sub-base is of wood, wood-screws will serve to fasten all parts to it, and it, in turn, to the panel. If an aluminum sub-base is used, machine screws (6/32) and nuts will be required.

The wiring is quite simple, requiring

only the usual bus-bar, spaghetti, well-tinned soldering iron, non-corrosive paste and resin-core solder. No battery binding posts are provided, the short ends of the color cable being terminated directly at instrument binding posts, while the long ends go directly to the batteries.

The preliminary testing of the set is quite simple. It should first have only the "A" battery connected to it, and the tubes inserted in their sockets. They should, of course, light, and have their brilliancy controlled by the rheostat. The negative "A" battery lead should be left connected and the plus lead removed and touched first to the "B" 45 and then to the "B" 90 leads. The tubes should not light with either of these connections. If they do, an error has been made in wiring and must be corrected before proceeding further.

The tubes being in their sockets, the rheostat should be turned about seven-eighths on for storage battery tubes. The proper adjustment for UX-199 tubes (dry cell) may be arrived at by the use of a filament voltmeter, which is vitally important for use with this type of tube.

Two of the larger size oscillator coils and antenna coils should be put in their respective sockets, and the balancing condenser turned all out. Then, if the potentiometer is turned from its positive to its negative side, a "plunk" will be heard, followed by squeals if the oscillator dial is rotated. The potentiometer should be turned back far enough so that no squeals will be heard, in which position it should be left unless it is desired to vary the signal volume with it.

If the oscillator and antenna dials are rotated slowly, varying the oscillator through a range of 10 degrees above to 10 degrees below the antenna setting for each 2-degree step with the antenna dial, signals will be heard if any local stations are operating. An antenna not over 40 to 60 feet long, indoor and outdoor, and a ground, may be connected to terminals 1 and 2 of the antenna coil socket, the one just behind the antenna condenser and first detector tube. Selectivity may be regulated by adjusting the position of the rotor coil with the fingers. Once set, it need not be disturbed. This is true for all sizes of antenna coils, for the different wave-length bands.

The oscillator coupling is not generally critical and the oscillator rotor should have its axis coinciding with that of the stator tube to start with. Selectivity may be improved by turning it slowly out. It will be found, however, that turning it a full 180 degrees around may increase signal strength on weak stations. In some extreme cases it may even be necessary to connect it in the first detector grid lead rather than in the filament return. This should be tried at once, should the receiver fail to operate properly.

In first tuning the set few signals will be heard, due to the extreme selectivity.

(Continued on page 27)

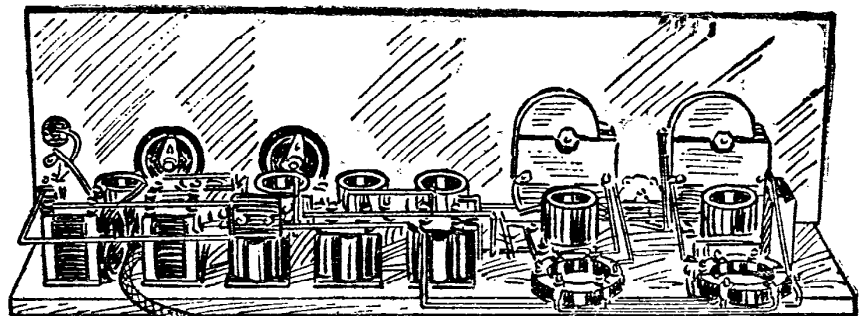

This view of the new super shows the arrangement of the parts with the two receptacles for taking the inductances. The model pictured is the unshielded type.

The Cotton Superheterodyne

Construction Data on a New Super which Has Proven Highly Efficient

IT is acknowledged by the majority of radio authorities that the Superheterodyne is the peer of all radio sets. This statement is true only insofar as practical constructional work gives the builder a set which operates as well in practice as its theoretical design intends it to.

Unfortunately many of these receivers which have been constructed in the past do not operate to full efficiency. This is due to many reasons, among which are, poor or mediocre parts, poor design or layout or poor workmanship in the construction of the set.

The Superheterodyne described herewith appeared in the weekly radio supplement of the *Los Angeles Evening Express* and was modeled after an article by R. W. Cotton, the designer. In the article on Mr. Cotton's Superheterodyne many valuable pointers are given on the selection of parts as used in the original set.

While the following description covers principally the assembly and wiring of the set rather than constructional details of particular parts, the constructor who intends to build the set with purchased parts as shown in the accompanying pictures will find this information of great assistance.

Parts

The parts necessary to construct this receiver are not as many or expensive as the general public has been led to believe. The author has discussed each part separately in this article, telling what to look out for in purchasing parts, and what seem to him to be the best parts for the particular purposes for which they are wanted.

By that it is not meant to imply that other parts are not as good, but it is impossible in picking out a design, to try out all of the various parts on the market, and it has been the designer's experience that of the numerous Superheterodyne sets which he has constructed, the parts listed herein are the best for the set described herein.

There is one fact to bear in mind which the author cannot over-emphasize, and that is this: Use the best parts and remember that "The best is the cheapest in the long run."

This receiver is for loop reception, as this method in general is the best because of its portability, selectivity, and less interference from static—both "man-made" and atmospheric.

The specifications of the loop which is suited to this receiver as shown in Figure 1, are as follows:

Length of long sides—25"; length of short sides—12½"; distance across the top of the loop—18"; total height of the loop—33".

The wire on the loop is wound on 5/16" centers and is composed of 12 turns of No. 18 Belden insulated braid with a tap taken off at the exact center of the wire. The pieces of wood which

support the wire are 4 by ¾" thick by 1½" wide and notches are cut in one side of these, which are ⅛" deep and 5/16" on centers to accommodate the wire. The loop frame should be made of any good dry 1" square wood.

the average experimenter's mind as to the relative merits of Litz wire as against that of ordinary stranded wire. If the constructor is building his own loop, the advantage of having Litz wire is probably not worth the extra amount

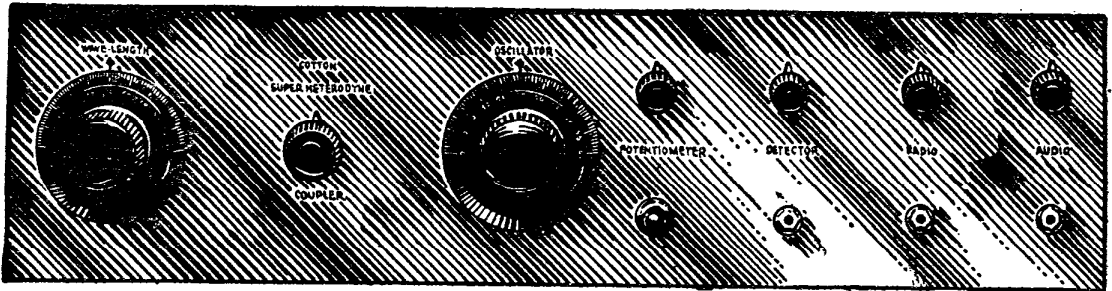

Illustrations by Courtesy of Los Angeles Evening Express
A front view of the Cotton Superheterodyne. The tuning controls are at the left and the filament controls and jacks at the right.

LIST OF PARTS

- 8—Cle-ra-tone Sockets.
- 1—Chelton midget condenser.
- 2—15 ohm rheostats.
- 1—5 ohm rheostat.
- 1—200 ohm potentiometer.
- 2—DX National condensers .0005 with 4-inch dial.
- 3—Grid leak mountings.
- 1—Carter "Imp" battery switch.
- 2—Carter Hold-Tite jacks, Double Circuit.
- 1—Carter Hold-Tite jack, Single Circuit.
- 1—Samson Super-Kit, including:—
 - 1—Samson oscillator coupler.
 - 1—HW-RI 5,000 meter filter.
 - 3—HW-RI 5,000 meter intermediate frequency transformers.
- 9—Eby binding posts.
 - [3—Loop; 1 A—; 1 A+B—; 1 B+Det; 1 B+ Amp; 1 C—; 1 C+.]
- 1—HW-A2; 6:1 Ratio Samson audio transformer.
- 1—HW-A2; 3:1 Ratio Samson audio transformer.
- 5—No. 601 Micadon fixed condensers.
 - Capacities: 1—.005 mfd.
 - 2—.0005 mfd.
 - 2—.001 mfd.
- 2—1 mfd. by-pass condensers.
- 3—Daven grid leaks.
 - Resistance: 1—.05 meg. with mounting
 - 2—5. meg. with mounting
- 1—Front panel, 7"x28"x3/16".
- 1—Base panel, 8"x27"x3/16".
- 3—Brackets.
- 1—Small knob for coupler.
- Bus bar, spaghetti, soldering lugs, solder, etc.

It is recommended whenever possible that the constructor purchase a ready-made loop, as there are several good ones on the market to select from. Bear in mind that the loop which you purchase must have a mid-tap, and should be of the same general style as shown in Figure 1.

There is a great deal of question in

of money which the use of Litz would involve.

There are a great many people who desire to use an antenna and ground with any receiver they may use. If it is desired to use an antenna with this set, all that is necessary is to connect the antenna wire to the ground wire by means of approximately seven or eight feet of stranded insulated wire. This wire may be turned once around the outside of the loop.

In selecting panels, both for the front and base of this set, the constructor is given considerable latitude in that he may use hard rubber, bakelite or many of the composition panel materials available on the market. If hard rubber is used, the panel should be ¼" in thickness; otherwise 3/16" will be satisfactory.

Bakelite is preferable, as this material seems to run more uniform and with perhaps a higher finish than some of the other materials.

It is recommended that the base panel be of this material or similar rather than of wood—although good dry wood or wood impregnated with paraffin is an exceptionally good insulating material. In a great many cases it has been found that wood which has not been seasoned has caused a great deal of trouble when used for baseboards—particularly if bare wires are led through the board and come in contact with the wood.

In choosing variable condensers for this set, it is well to purchase one of the so-called "low loss" type with a grounded rotor. There are many of these on the market, which are very good.

Be sure in buying this, that the minimum capacity is low—at least not more than .00002 mfd., this reading to be taken when the rotor plates are entirely removed from those of the stator.

There are two variable condensers of .0005 mfd. maximum capacity required for this set. Also one small variable feed back condenser of approximately .000045 mfd. maximum capacity, if regeneration is used in the first detector.

Referring to the wiring diagram of this set, it will be noted that the grid condensers of the first and second detectors are in the usual position, and that the grid leaks are connected from the grids to the positive ends of the filament.

With the grid leaks connected as

shown in the diagram, it makes no difference to which side of the filament the grid return is connected, since there is no direct current in the grid return, owing to the presence of the grid condenser.

In the oscillator circuit you will note also a grid leak and grid condenser. This is essential for satisfactory operation of the oscillator over the entire range. Without the grid leak and condenser, a large amount of energy is lost in the grid circuit when the oscillator is

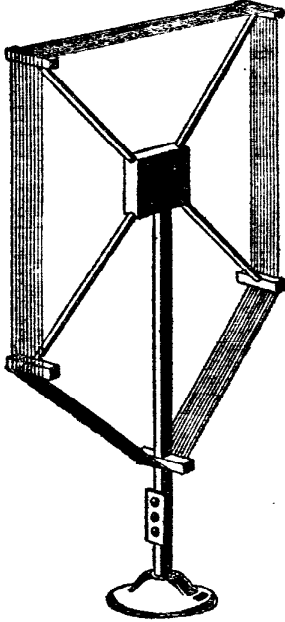

Fig. 1. The loop aerial used with the set may be constructed as shown above.

in operation, since for a part of the time during each cycle the grid is positive.

A UV201A tube will operate best as an oscillator with a grid leak of about 30,000 ohms, although this value is not critical. A grid leak of 50,000 ohms or .05 megohms will work very satisfactorily.

The grid oscillator condenser only acts as a by-pass for the alternating current and need only be large enough to serve this purpose. For the oscillator in question, a value of about .005 mfd. will be good, although a .004 mfd. or a .006 mfd. will do as well.

The oscillator coupler shown in the

it will not be found that part of the time the heterodyning has been done by the harmonics and part of the time by the fundamental. For the proper operation of the 5,000 meter transformers, the oscillator must range in wave-length from about 215 meters to about 600 meters. This variation can be obtained within the scale of the ordinary .0005 mfd. condenser dial.

In order to accomplish this wide variation in wave-length, it is necessary that the winding of the plate coil on the coupler shall not be of wire of too small a cross section, for as the cross section becomes smaller, the winding is more compact with the attendant increase in self capacitance, which tends to make the lowest frequency obtainable with the coil in the oscillator circuit higher than it would be were this capacitance not present, and this apparent capacitance adds to that of the variable condenser.

Another fact which cannot be overlooked is that in order for the oscillator coil and condenser to "oscillate," the energy necessary must come from the tube, or more properly from the "B" battery through the relay action of the tube. In order for this to happen, the coupling between the oscillator coil and the grid coil must be right. In an oscillator designed for use for the Superheterodyne, frequency variation from one extreme to the other must be obtained by a single, uniform adjustment for convenience. This means that there can be but one coil and but one condenser.

For any given frequency, there is one best relationship for the oscillator coil, the grid coil and the condenser. In the oscillator for the Superheterodyne, a compromise must be made. Above all else, the compromise must not affect the stability of the oscillator. If the oscillator is made up of the ordinary tuned plate type, it will be found that if it oscillates very efficiently at the low frequencies, it will tend to become unstable at the higher frequencies if only the condenser capacity is varied.

In this particular coupler which is shown in the views, an extra tap is taken off the oscillator coil for the plate lead, which increases the stability at the high frequency end, and allows at the same time sufficient coupling between the plate and grid coils to ensure operation with vigor over the entire scale of the condenser. In order that the frequency variation shall be proper, it is necessary to make sure that the condenser used has a low zero capacity.

used in this particular part of the set.

The author tried out numberless amplifying transformers for this purpose, as well as constructing several himself, ranging in wave-length from 2,000 meters to 10,000 meters, both of the iron core and air core construction.

There has been a great deal of discussion as to which of these extremes is best, and each wave-length which is mentioned in this band will find its particular supporter, but the author has found that the 5,000 meter band seems to offer the advantages of both the higher and lower without some of their disadvantages.

There has also been a large amount of discussion as to the relative advantages of iron core transformers vs. air core transformers. In the design of the transformers used in this set, it is believed that a happy medium has been struck, as the transformers are primarily of the air core type with a very small amount of iron in them.

This iron is introduced only in a quantity sufficient to broaden the peak of the transformer. Great care is taken that it does not have the disadvantage of necessitating the tuning of each stage—or of matching the transformers. These transformers are sufficiently sharp so that great amplification is obtained, and yet they are not so sharp that they will not work properly together without matching, or so that the side bands are cut.

The Input or Filter Transformer is of the air core type, and brought to a sharp peak by the use of a .001 mfd. fixed condenser across its primary winding. This Input Transformer is sufficiently sharp to eliminate interference and cause sharp tuning, but its peak is broad enough so that none of the side bands are prohibited from passing through it—thus ensuring good quality of reception. By its use the first detector tube is enabled to operate most efficiently, since the condenser acts as a by-pass for the frequency of the incoming wave.

Regeneration in the First Detector

The reader will note that the diagram calls for a three-tap loop which is necessary in order to use regeneration in the first detector.

By using a three-tap loop and inserting a small feed-back condenser, it is possible to create regeneration, which adds the following properties to the operation of this set.

First, it makes the loop more directional;

Secondly, it makes the tuning sharper on the variable condenser, which tunes the loop;

Thirdly, it increases the sensitivity of the first detector tube;

Fourthly, it makes possible neutralization in the first tube if desired.

There are three rheostats required in this particular Superheterodyne—one controlling the first and second detector tubes of 15 to 30 ohms resistance; the second one controlling

the oscillator and the three intermediate frequency tubes of 5 to 10 ohms resistance, and one controlling the two audio tubes of 15 to 30 ohms resistance.

There are eight sockets required for this set. A high grade socket should be used—preferably of the non-metallic type, such as those made of glass, porcelain or all bakelite. In fact, any good socket may be used.

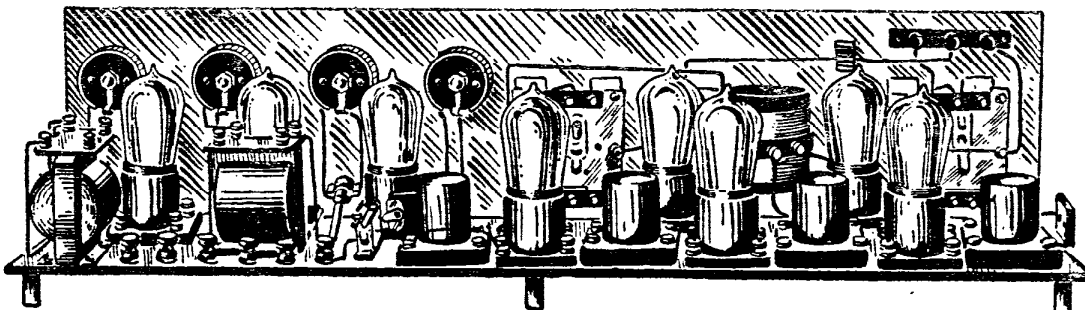

A back view of the receiver. Note the neat and even distribution of parts on the subpanel.

pictures of the set is manufactured by the Samson Electric Company, and is rather a departure in design from the ordinary coupler. On account of this fact the following data are set down to explain the reason for its design:

This coupler has been designed to give the necessary variation in frequency over the range of the 5,000 meter intermediate frequency transformers. This means that

A good condenser of the .0005 mfd. variety will have a zero capacity of about .000015 mfd.

The Intermediate Frequency Amplifying Transformers have been said to be the heart of the Superheterodyne circuit, and this statement is without question true, as the difference between a good Superheterodyne and an average Superheterodyne lies in the material

It is important particularly in the filter transformer, that fixed condensers which are of the capacity marked on them be used. These condensers should be of the mica type, with the exception of the large by-pass condensers, which may be of waxed paper and tin foil construction. All condensers must be sufficiently well constructed to withstand a high plate voltage.

On the input transformer it is suggested that the purchaser ask to have a .001 mfd. condenser tested on a capacity meter to ensure its being the correct capacity.

In trying out a great many audio frequency transformers in this circuit, it has been the experience of the designer that a 6 to 1 radio transformer in the first stage and a 3 to 1 transformer in the second stage seems to be the right combination.

Small tinned copper wire or insulated wire is the very best material to use in the construction of this set. Wire smaller than No. 14 is not recommended for use in the filament circuit, but smaller wire may be used elsewhere in the set.

Rosin core solder should be used, or plain solder with a mixture of rosin and alcohol as a flux. Never use paste or acid core solder, as this has a tendency to create trouble later on.

It is generally recommended that eight

for the filament current, using C301A or similar tubes.

Construction of the Set

It is rather needless to go into a long description as to how to construct the set. The photographs, layout, and wiring diagram are sufficient means for anyone to accomplish this work satisfactorily.

A few general ideas, however, may be helpful:

The first thing to do is to fasten the instruments to the base panel and to the

particular tube socket which you have the tube in, about half way on. If the tube lights in each place controlled by the rheostat corresponding to the socket in which the tube is inserted, you may be reasonably certain that the filament wiring is correct.

Then connect the "A" battery to the detector "B" battery terminals, taking one tube and inserting it in each socket as before. If the tube does not light this wiring is correct. Do the same thing with the "A" battery connected to the amplifying "B" terminals.

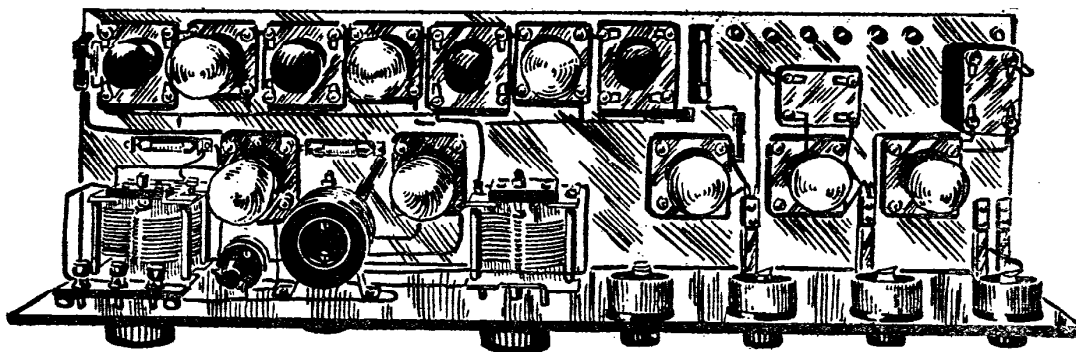

The Cotton Superheterodyne as it appears looking down from the top. Note that practically all of the wiring is beneath the subpanel.

front panel. Do not, however, put these panels together. Wire all that can be done on the front panel, and then wire all that can be accomplished on the base panel.

When these are finished, attach the front panel firmly to the base panel by brackets and finish the wiring from panel to base. Make all the joints rigid enough

Next connect the "B" battery to the "B" battery binding posts and insert the telephone plug in the detector jack. This should give you a click showing that the "B" battery circuit is correct. Now insert one tube in each socket successively with the filament current on, and if nothing happens, the "B" battery connections are not shorted with that of the "A" bat-

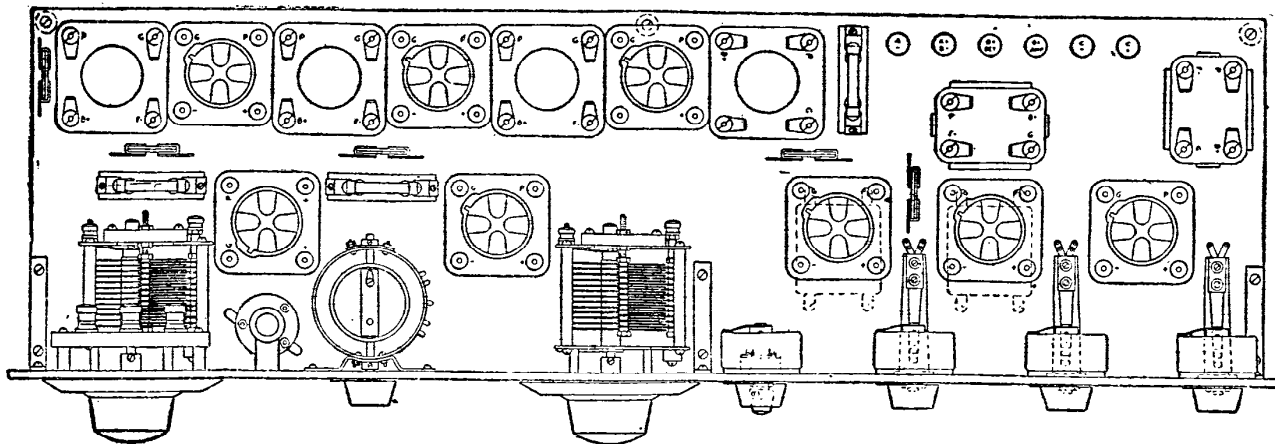

The layout of the set showing all parts in their proper position. Follow this arrangement as near as possible when assembling.

tubes of the C301A type or similar be used throughout. In case the experimenter wishes to use the D21 Sodian tubes as detectors in the place of the C301A type, the only necessary change to ensure best results is that the grid return be made negative instead of positive.

Any good "B" batteries may be used on this set. There are 90 volts used in all—45 on the radio frequency and detector tubes, and 90 on the audio amplifier tubes.

Although the first cost is greater, storage "B" batteries are recommended for any set of this character, as in the long run they are by far the cheaper, as the life of dry "B" batteries on a set of this character is not high, due to the current consumption—which is normally from 25 to 30 milliamps.

Any good 6-volt 100 amp. hour storage battery or larger is recommended

so that it is possible to slide the set on your table by the joint which has just been made. This will save you the trouble of broken connections at some later date.

The assembly layout shows each part in its proper position and the set can be wired according to the schematic diagram. The best way to construct the set is to do all of the filament wiring first. Then follow with the wiring of the "B" battery connections; this in turn, may be followed with wiring of the loop tuning circuit and the oscillator circuit.

Testing and Preparing for Operation

The first thing to do is to be sure that the wiring is correct so that the tubes will not be burned out; connect your "A" battery to the "A" battery binding posts, taking one tube and inserting it in each successive socket with the filament switch on and rheostat controlling

tery. Now put all tubes in their respective sockets and connect the three tap loop to the three binding posts. The center tap of the loop must by all means be connected to the center binding post.

Turn on the detector tubes to approximately normal brilliancy, which will be about three-quarters of the rheostat. Follow this by turning on the intermediate frequency amplifiers and the oscillator by means of the rheostat which controls them, to their normal brilliancy. Be sure that the midget condenser is at its minimum capacity. When listening to a low wave-length station, 1,000 or more miles away, move the midget condenser up to the point where the greatest signal strength is obtained without distortion. In some cases it may be possible to throw the first detector tube into oscillation by means of this small condenser, and of course it would be set

just beneath this point. Now that this condenser is set, it will not have to be varied.

On a station of at least 1,000 miles away, make the adjustment of the oscillator rotor to the minimum coupling position that it is possible to attain without decreasing signal strength. This may be accompanied by a small change in the

Now turn the potentiometer to the left until there is a click, showing that the radio frequency amplifier has gone out of oscillation. Now rotate the oscillator condenser dial slowly together with that of the loop tuning dial. These will run fairly uniform, not more than ten degrees apart.

This testing should occur when local

receiver itself: "A" or "B" batteries discharged; loop phones or loud speaker out of order; broken connections leading to the set; poor tubes.

If none of these are found to be the trouble, try a pair of phones across the primary of the input transformer, turning the oscillator dial if whistles are heard. This shows that the first detector

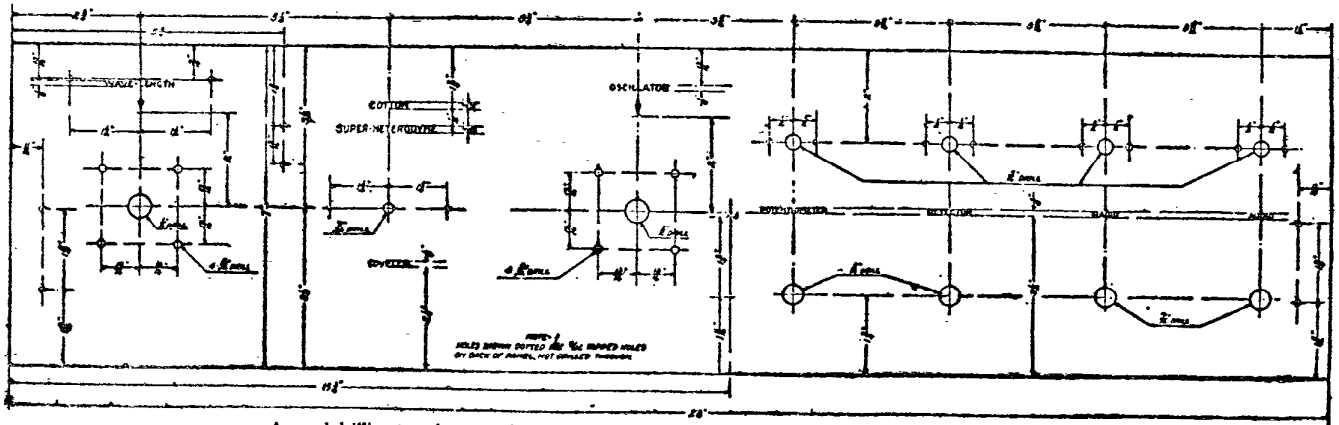

A panel drilling template may be drawn on a sheet of paper according to the dimensions given above.

oscillator condenser dial. Now that this adjustment is fixed, it need not be changed, except when a new oscillator tube may be inserted in the oscillator socket.

Try out the different tubes in different positions throughout the set, as some act in one capacity better than others. Now place the potentiometer about midway of its arc; by turning this to the

broadcast stations are known to be in operation, and as the oscillator dial is turned, the station will be heard to come in.

Now turn the loop tuning dial to the point at which the music or speech comes in the best. Also do this with the oscillator dial. Then move the potentiometer on to the right within a short way of the point where the radio

tube and oscillator are working properly. This leaves the trouble to a large extent in the intermediate frequency amplifier which should be tested again very carefully.

If the potentiometer does not control the oscillation of the intermediate frequency amplifying tubes, their circuit should be looked over, as there is probably a broken connection in the wiring,

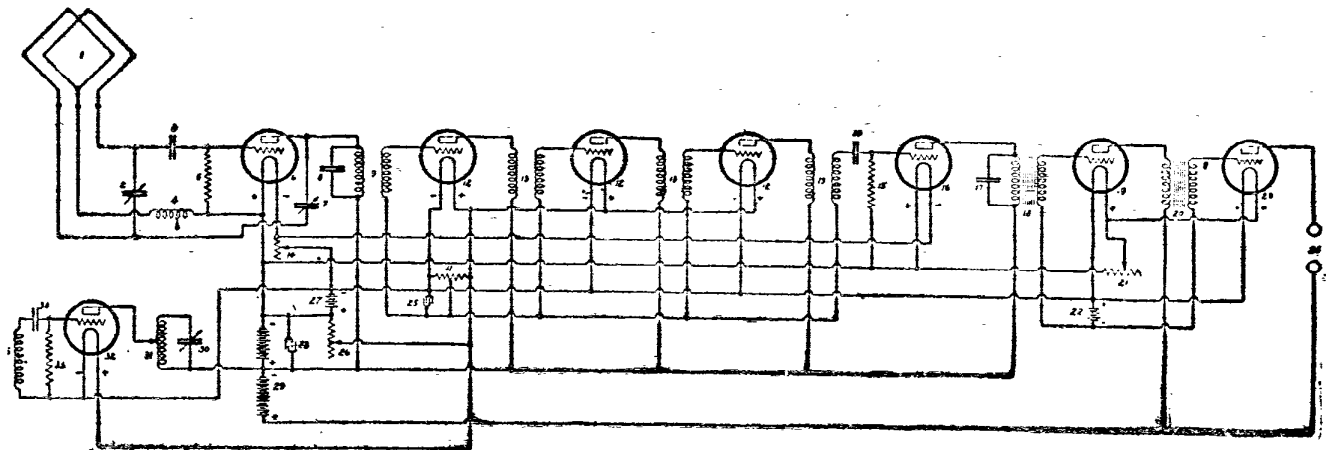

The circuit diagram of the Cotton Superheterodyne. The set is wired to correspond following the key to the parts as given below.

1 Center tap loop		13 Samson HW-R1 transformers	60 cc.	25 Pot. by pass condenser	1mf
2 Loop condenser	.0005 m.f.	14 2nd Det grid condenser	.0005 m.f.	26 Radio rheostat	5ohms
3 1st Det grid condenser	.0005 m.f.	15 2nd Det grid leak	3-5 meg.	27 "A" Battery	
4 Oscillator pick-up coil		16 2nd Det tube		28 "B" Battery by-pass condenser	1 m.f.
5 1st Det grid leak	3-5 meg.	17 Phone condenser	.001 m.f.	29 "B" Battery	90 volts
6 1st Det tube		18 Samson HW-AE transformer	5-1 volt	30 Oscillator condenser	.0005 m.f.
7 Feed-back condenser	.000043 m.f.	19 1st audio tube		31 - plate coil	
8 Filter condenser	.001 m.f.	20 Samson HW-AE transformer	3-1 ratio	32 - tube	
9 Samson HW-R1 Filter	60 cc.	21 Audio rheostat	15ohms	33 - grid leak	.05 meg.
10 Detector Rheostat	15ohms	22 "C" Battery	4.5 volts	34 - grid condenser	.005 m.f.
11 Potentiometer	200 ohms	23 2nd audio tube		35 - grid coil	
12 Radio frequency tubes		24 Output terminals			

right you should notice a decided click. This shows that the radio frequency tubes have gone into oscillation.

Leaving the radio frequency tubes in this manner, slowly rotate the oscillator dial. If whistles are heard, it shows that the oscillator is performing its function.

frequency amplifier goes into oscillation. This potentiometer may be set at this point, and very rarely need be changed.

Trouble Shooting

If the set does not function as outlined, you should look for the following sources of trouble before blaming the

If body capacity is apparent in the tuning of the loop condenser, this would indicate that the first detector tube is in an unstable condition. To overcome this, reduce the amount of capacity in the midget condenser and cut down the filament current in the detector tube.

How to Construct the Hetro Five

Building of Set and Making Coils Are Explained in Detail

FIVE tubes, performing in a Superheterodyne system and doing their work not only as well but somewhat better than does the same quintet in any other type of five-tube receiver—that is the radio accomplishment now possible for any fan. And, in addition, such a system will function on four tubes with plenty of volume for an ordinary sized room. Not only that, but all of the selectivity of the large superheterodyne is retained.

Thus the first of C. E. Butterfield's article reads in a recent issue of *The Chicago Evening Post*. Mr. Butterfield goes on to give a further description of his "Hetro Five" as follows:

Superheterodyne, in which reflexing was used. Then along came McMurdo Silver, who, using the Pressley bridge type of oscillator—"detector"—also cut the superheterodyne to six tubes by sharpening up the long-wave amplifier and holding it to two tubes.

Now another tube has been cast aside and we have the "Hetro Five." It was done, too, with no reflexing, which will give the fan plenty of trouble alone without hooking it into a Superheterodyne system. In fact, several efforts have been made to design five-tube sets by reflexing the intermediate amplifiers. The writer does not wish to discourage any reflex fan or deride any reflex set, home

ly all of the amplification. So it was necessary to help along the lonely tube by providing an amplifier that would "perk" from the word "go." So again the Tropadyne was called upon. From it the hint of tuned long-wave transformers was thoroughly looked into. Immediately the amplifier stepped into action. Then was tried a "different" type of transformer. Tuned honey-comb coils were used. They worked like a top, until the set was tried under the caves of a broadcasting station. Not so good. More trials and tribulations. A weeding-out process was put under way and transformer after transformer was literally looked into and then given a back seat.

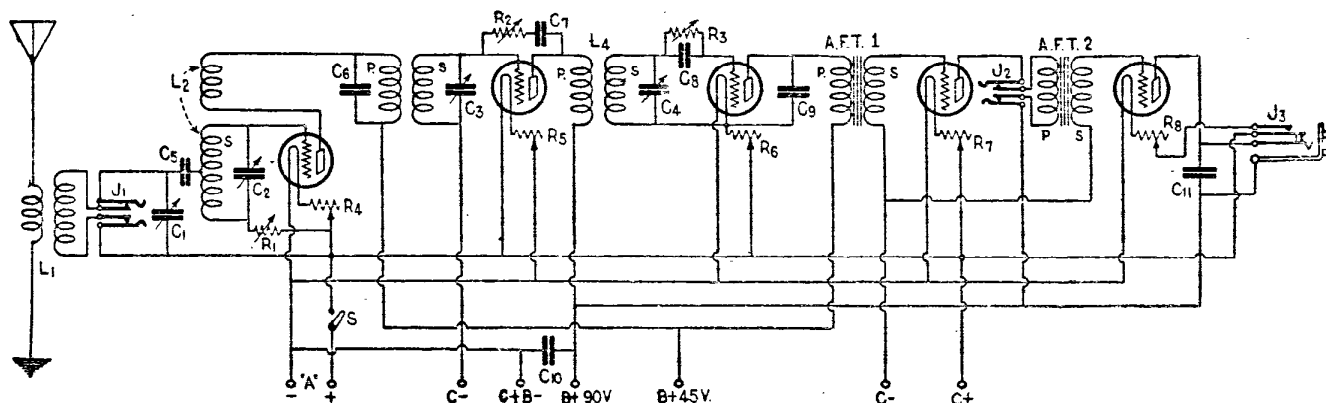

Complete diagram of Mr. Butterfield's Hetro Five. Standard parts are used in this circuit. Coil L3 can be seen between condensers C6 and C9 and is a long wave transformer as is L4.

Illustrations by Courtesy of The Chicago Eve. Post

In presenting for the first time the "secrets" of the "Hetro Five," the writer also offers an improved inductance coil, which may be used in any type of radio receiver. The coil, which has been given the "title" of "Figure 8 low loss, high inductance," while offering somewhat of a task in its construction, provides not only high inductance, but has an extremely small external field, requires very little room and has the lowest possible "pick up." That is, the coil will not act as a small loop, as does an ordinary large solenoid, thus giving sharper tuning.

Attempts to Reduce Tubes

Analysis of the diagram of the "Hetro Five" immediately calls to mind the Tropadyne, designed by Clyde J. Fitch. In fact, the autodyne type of oscillator, such as he used, with tuned long-wave transformers, was adopted by the writer in his task of squeezing a Superheterodyne into five tubes and still getting the necessary volume. Of course, all of this was not accomplished in a minute, and several months of experimentation were required before the set was evolved. Besides, numerous changes were necessary over the original Tropadyne, which contained seven tubes.

Numerous attempts have been made within the last year to design a practical Superheterodyne functioning on fewer tubes than the old eight or nine-tube sets. Fitch and others lopped off a tube by successfully combining the oscillator and the frequency-changer tube. Another tube was cut out in the latest Armstrong

made or otherwise, but he desires only to call attention to the difficulties that the fan sometimes encounters in building the reflex, let alone trying to add it to the Superheterodyne.

Is Non-Radiating

So we forget the reflex idea, and give each tube only one job, except for the combined oscillator "detector," which has no more tasks to perform than does the detector in an ordinary regenerative set. Also we adopt the Tropadyne oscillator in preference to other autodynes because it was believed to do the work better.

Another fact that is a credit to Fitch's oscillator is that the oscillation circuit is isolated from that of the antenna, making it impossible to radiate energy into an aerial, as do many of the Superheterodynes now in existence. Of course, the same is true of the Pressley system, but we are not extolling its merits and are only interested in the set at hand. And the "Hetro Five" will not put oscillations into the antenna to worry all of the neighbors, no matter what type of aerial is used.

After selecting the desired frequency-changer circuit, the big task came in building an intermediate amplifier that would amplify properly without corraling a small family of tubes. It was decided that the tube boiling-down process must take place in the amplifier. That's easy, was the first thought. All of the amplifying tubes but one would be forgotten. Simple? Extremely so, but along with the missing tubes went near-

Finally the Remler tuned stage transformer, which operates on a peak wavelength of 6,666 meters, or forty-five kilocycles, was given the job in the amplifier. Eureka! The days of grief were over. Recommendations which accompany each carton containing the Remler transformer were ignored. The engineers who designed that transformer did not know what the writer was up against. So instead of using only one of the Remler TS transformers, two were gathered in, one used as an input or "filter" transformer, and the other given the job of passing the signal onto the long wave detector.

The input transformer was tuned as sharp as possible. A .0005 fixed condenser was placed across the primary, with a .0005 variable across the secondary. Another .0005 variable was used across the secondary of the second transformer.

The reader probably wonders by this time if the writer is attempting to press-agent the Remler products. But he is only attempting to save a lot of grief for the fan who builds the "Hetro Five." Unless the builder desires to experiment and go over the same field already covered by the writer, he will do well to follow instructions as to the few particular instruments that are specified here and there. By the way, this Remler transformer is Type 610, so don't forget it. The Type 600 Remler will not function properly in the "Hetro Five."

Passing to the long-wave detector, an attempt was made to incorporate regeneration through a feed-back coil. But it

didn't mean anything. It worked fairly well when honeycomb transformers were used, but it was found with the change in transformers that there was plenty of regeneration without adding this extra unit. So the ordinary straight audion detector was incorporated in this set.

Returning to the long-wave amplifier, it will be noted that no potentiometer is used. Tests showed that its use cut down the volume, although it did prevent oscillation. So the Farrand system of regeneration control was selected. It consists merely of a blocking condenser and a variable resistance, such as the Bradleyohm. Also an aid in building up the volume was the separate C battery incorporated in the amplifier circuit. Its value will range from $1\frac{1}{2}$ to 3 volts.

The audio hook-up is standard, except that it was found that with the laboratory audio transformers the bypass condenser, C9, was not needed. However, it is best to try the set both with and without this condenser.

In constructing the "Hetro Five," the builder is advised to pick up the best material on the market. And he should, where such instruments are specified, buy those listed in the outline of parts. The other material in the set can be any good equipment.

No panel layout is given, nor is an outline included for the subpanel or baseboard, because the writer feels that the fan who will build this set is so far advanced in the radio art that a map of a panel is an unnecessary evil. Besides, mounting templates vary with the instruments purchased, and a panel and baseboard diagram is virtually useless unless the builder buys identical material, and what fan does not have his own pet instruments?

As to Panels

In starting with the antenna circuit and continuing to the last jack, a number of hints will be given. In the first place, the recommended panel size is 7x26, although a panel two inches shorter may be used by slightly crowding the instruments. The baseboard should be two inches shorter than the panel, and the same is true if a subpanel is used.

Here let us say a word regarding subpanels. This set lends itself very readily to subpanel construction, due to the fact that the two variable condensers, which tune the long-wave amplifier, may be mounted in the rear of the set. Such is the case with the two Bradleyohms and the grid leak, as it is necessary to adjust these instruments only for the best reception and then forget them, unless one wishes to experiment.

In the writer's set a subpanel was used, it being mounted on brackets which were attached to the panel. The antenna and the oscillator condensers were mounted at the left-hand side of the panel with enough room between them to permit the placing of the oscillator tube. The loop jack was placed in the lower left-hand corner of the panel. At the rear of each condenser was placed its respective coil.

Also on the panel were put three rheostats, one each for the oscillator, the amplifier and the detector. Rheostats were used on these tubes because it was felt that they required closer filament adjustment than did the audio tubes, which were controlled through amperites. The filament switch was put at a convenient place, with two jacks at the lower right-hand corner.

The loop jack is optional, although it permits the use of a very small pick-up system for local and some distance use. The first audio jack was placed in the plate circuit of the first audio tube, providing plenty of volume for local stations and such distant transmitters as KDKA.

The other audio jack was a filament-control type, this being used because of the adoption of amperites.

If a baseboard is used, the builder must provide some method of mounting the two long-wave tuning condensers. One method that suggests itself would be small panels attached to the rear of

PARTS FOR "HETRO FIVE"

- L1—Antenna coupler.
- L2—Oscillator coupler.
- L3 and 4—Long-wave transformers (Remler tuned stage transformers, type 610).
- AFT1 and 2—Audio-frequency transformers (laboratory type preferable).
- C1 and 2—.0005 variable condensers of any good make.
- C3 and 4—.0005 variable condensers (Rathbun preferable because of small space required).
- C5—.0005 fixed condenser.
- C6—.0005 fixed condenser.
- C7—.001 fixed condenser.
- C8—.00025 fixed condenser.
- C9—.006 fixed grid condenser.
- C9—.006 fixed condenser (optional).
- C10—One mfd. fixed condenser (B battery bypass).
- C11—.006 L. S. bypass (optional).
- R1—Bradleyohm, range 5,000 to 50,000 ohms.
- R2—Bradleyohm, range 25,000 to 250,000 ohms.
- R3—Grid leak (variable preferred—if fixed leak used 5 megs).
- R4, 5 and 6—Rheostats to fit tubes used.
- R7 and 8—Amperites to fit tubes used.
- J1—Double circuit jack for loop antenna (optional).
- J2—Double circuit phone jack.
- J3—Single circuit filament control jack.
- S—Filament battery switch.
- Two C batteries.
- Panel—7 by 26.
- Subpanel or baseboard—7 by 24.
- One-half pound No. 22 D.S.C. wire.
- Five sockets for 201-A type of tubes.
- One dozen binding posts, wire screws and other desired hardware.
- Five 201-A tubes.
- Note: If bakelite subpanel is used, subpanel brackets will be required.

the baseboard. The same is true of the Bradleyohms and the variable leak, although these may be put on the panel.

Where a subpanel is used, a number of hints are in order. In the first place, it conceals practically all of the wiring and provides a method for the mounting of the variable instruments whose adjustments do not require that they be placed on the panel. These include R1, which is put as close as possible to the oscillator tube; R2, placed near tube, No. 2, and the grid leak for the second detector. R1 is a Bradleyohm with a range from 50,000 to 500,000 ohms; R2 is another Bradleyohm with a range of 25,000 to 250,000 ohms; R3 may be any good variable leak.

In addition, the subpanel provides an excellent place to mount the long-wave tuning condensers. Rathbun's .0005 were used in the writer's set because they required very little space and lent themselves readily to subpanel mounting. A small dial is recommended. The Remler transformers were mounted contrary to all rules and regulations. They were turned upside down and holes bored in

the subpanel through which the binding posts on top protruded. These were fastened from the bottom, with soldering lugs under the nuts.

All of the fixed condensers may be supported by the wiring if the proper type are purchased. Almost any type of sockets lend themselves to subpanel use, although some will be found that require considerable ingenuity to place properly. Audio transformers of almost every make are easily adapted to a subpanel.

Before starting construction the builder should lay out all of the instruments, both on the panel and baseboard or subpanel so that he will not crowd off a necessary unit. On the writer's set a voltmeter, with a switch so that the first three tubes could be cut in on its circuit, was incorporated, but this is only a refinement that complicates the construction.

The Inductances

While the writer has attempted to point out all of the intricacies of the "Hetro Five's" layout, he may have dropped some out, but he leaves those to the ingenuity of the builder.

Two coils, both of which should be home made, are needed. The antenna coil circuit may be any type suitable for a .0005 condenser. In the diagram it is L1. If the Figure 8 coil is used—and its construction will be explained later—the primary will require seven turns and the secondary thirty-seven turns. If an ordinary solenoid is used, the primary should be about nine turns, with forty-nine-turn secondary.

The oscillator coil (L2) is wound in two sections. The grid coil, using the Eight type, has thirty-nine turns, tapped exactly in the center, or at the end of $19\frac{1}{2}$ turns. The plate coil, which is coupled to the grid coil, consists of sixteen turns. If the solenoids are used, the number of turns should be: Grid coil 47, tap $23\frac{1}{2}$, plate coil 18. The plate coil is put on one-half inch from the grid winding.

The connections on the oscillator coupler are standard. That is, the beginning of the grid coil goes to the grid of the tube and the end to the filament. The beginning of the plate coil is connected to the B battery and the end to plate of the tube. However, if a mistake is made and the connections placed wrong, all that is necessary is to reverse the connections on one of the coils. Wrong connections make themselves known by refusal of the first tube to oscillate, a condition that is evidenced by the lack of a signal.

The Eight coil may be mounted at the rear of the condenser with two bakelite strips. Provision should be made so that the coupling of the oscillator coil can be varied, although it may be permanently set about one-half inch from the grid coil.

In connection with the grid coil, the placing of the tap exactly in the center is important, as its location is instrumental in preventing oscillations from reaching the antenna.

Wiring Not Difficult

Wiring of the set is a comparatively simple matter. It is all straight away. All that is necessary is to follow the diagram closely. Grid returns are clearly indicated. Note should be taken of the fact that the wire leading from R1 should be connected between the tube and the rheostat. If this is not done, varying the resistance of R4 will have an effect on R1. All the fixed condensers listed are absolutely necessary except C9 and C11. C9 will be required on some audio transformers, while with others its use is unnecessary. C11 is a refinement that is not absolutely needed.

Two C batteries are used, one in the long-wave amplifier circuit and the other in the audio. Another hint that should be called to attention is the placing of the oscillator and antenna coils. These should be mounted at right angles if solenoids are used. When using the Eights, the only care required is that the coils be at least two inches apart, whether at right angles or not.

Binding posts for the various batteries may be placed on the subpanel if one is used, or swung on a bakelite strip below the panel. When using a baseboard the posts may be placed on a bakelite strip raised about an inch above the board.

Making the Eight Coil

In the instruction of the Eight coil, a block of hard wood 4 inches square and twenty-four wooden pegs, such as may be obtained from spoked spider-web

and one-quarter inches. If it is desired to use solenoids, the diameter of the tubing should not be less than three inches nor more than three and one-half.

When the coil winding is completed, a needle and stout thread are used in holding it together. It will be noted that there are small apertures in the coil over each of the small holes in the block. Through these spaces in the coil the needle is pushed, so that it comes out the bottom of the block. Now the needle is pushed back through the same hole, but outside the coil. Moving to the next hole, the head of the needle is pushed into it, but outside the coil. Coming back, the needle is pushed up through the coil. The thread is tied at the top of the coil, and the sewing process is continued around the coil and across the center spaces.

With the outside sewing completed, the coil is slipped from the pegs. Care

Antenna Coupler

In making the antenna coupler the seven-turn primary is wound on the pegs first. Then is put on the thirty-seven-turn secondary. In making the oscillator coupler, the constructor must not overlook the halfway tap on the thirty-nine-turn grid coil; that is at the end of nineteen and one-half turns. The plate coil, as has been stated, has sixteen turns.

The fan may think that the number of turns given is too few for the condenser used. But the peculiar construction provides a higher inductance with a lower dielectric loss, giving a more efficient coil with less wire, and providing a wave-length range with a .0005 condenser from 550 meters down to above 150 meters.

With our set completed, our task is not yet finished, for we have a number of adjustments to take care of. The tuning of the set will not be described,

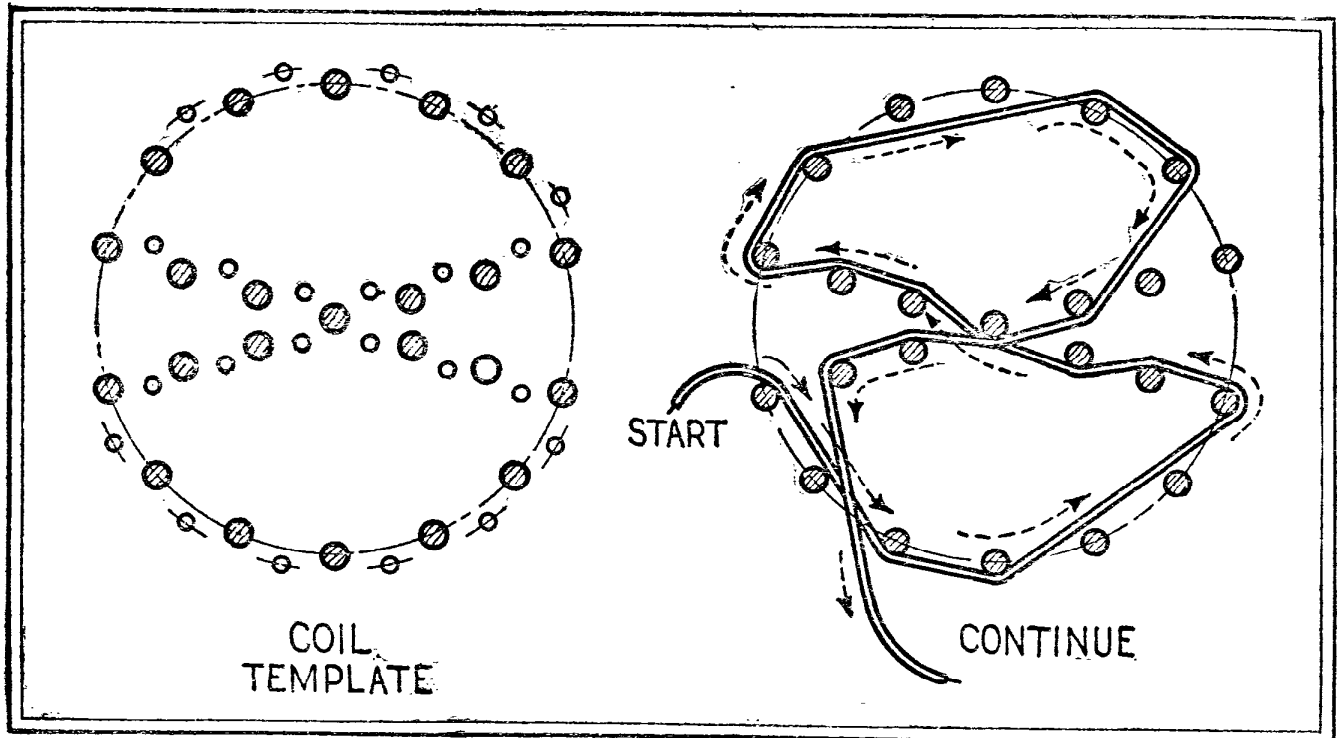

Twenty-four pegs are used in making the form on which to wind the figure eight coils. Care should be taken to have the pegs placed properly or otherwise the coil will not be satisfactory. Note should be taken of the fact that to obtain the Lorenz winding it is necessary to wind the wire over two pegs and under two. This makes every fifth turn follow the same path. The template should be drawn on paper and glued to a block of hard wood, and a bit slightly smaller than the pegs should be used to bore the twenty-four holes represented by the large dots. The diameter of the coil should be three and one-quarter inches. A 3-32 drill is used to bore the holes represented by the smaller dots, they to be used in sewing the coil.

forms, are required. The template illustrated is drawn on paper. A bit—such as is used in panel drilling—slightly smaller than the pegs is needed. Drill twenty-four holes in the block, one at each of the large dots. Now, with a 3/32 bit drill out the smaller dots. These holes are to be used during the sewing of the coil. The pegs are then driven into the large holes, which, by the way, should be drilled so that pegs slant outward slightly. However, the holes within the circle must be absolutely straight. The method of winding, which is the Lorenz system, is clearly illustrated. That is, the over two pegs and under two method is used. The only care required is that no pegs be skipped, for if this is done some of the turns will be placed side by side, defeating one of the benefits derived from the coil. Of course, the wire should be put on as tightly as possible.

The maker is advised to use wooden pegs and not metal, as the metal pegs tend to rub off the insulation on the wire, resulting in a shorted coil. The diameter of the template should be three

and one-quarter inches. If it is desired to use solenoids, the diameter of the tubing should not be less than three inches nor more than three and one-half. When the coil winding is completed, a needle and stout thread are used in holding it together. It will be noted that there are small apertures in the coil over each of the small holes in the block. Through these spaces in the coil the needle is pushed, so that it comes out the bottom of the block. Now the needle is pushed back through the same hole, but outside the coil. Moving to the next hole, the head of the needle is pushed into it, but outside the coil. Coming back, the needle is pushed up through the coil. The thread is tied at the top of the coil, and the sewing process is continued around the coil and across the center spaces.

With the outside sewing completed, the coil is slipped from the pegs. Care should be exercised in doing this so that the insulation on the wire is not scraped off nor the coil bent out of shape. After the coil is off the pegs the inside apertures are sewed, as were the outside. This is much easier, as the block is not now in the way.

If the proper care is taken, it will be noted that we have a coil that has no support except the wire itself, and the thread which holds it together. The thread should be the stoutest obtainable, as it is under quite a strain in the sewing. The wire best suitable is No. 22 double silk covered, or 22 double cotton. A coil wound in this fashion will consist of two small solenoids whose magnetic fields are opposed. This gives a coil that may be placed fairly close to another in a set without causing unnecessary coupling. With its field so small, it will not pick up stray radio-frequency current, and it handles only that which enters through its lead wires. It contains all of the features of the Lorenz coil as well as the D coil, which, in a sense, are its parents, as well as having a number of its own.

as it operates like an ordinary Superheterodyne. That is, two places will be found on the oscillator condenser at which most stations can be brought in. Nearby stations, such as those within a half mile or so, may come in at more than two places, but these should give no trouble.

After testing the filament circuit to see that the tubes light and that the B battery has not been shorted onto the filament circuit, the aerial and ground are connected, and a station brought in. The set will probably be found to be oscillating violently and it is up to us to correct this evil with the adjustments provided back of the panel. In the first place, R2 is adjusted until oscillation stops. Then the oscillator dial should be turned to zero. As this point is neared a high-pitched whistle will probably be noted. Now R1 should be adjusted until the whistle disappears.

Learning how oscillation is controlled, we next proceed to perk up the long-wave amplifier. This is done by adjusting the two long-wave condensers. About

(Continued on page 22)

A New Superheterodyne

BY McMURDO SILVER, A.I.R.E.

In this article is described a Superheterodyne receiver of a new type, which can be built in a very compact style.

THIS latest six-tube Superheterodyne has been called the "Superautodyne" since this name is justified by the use of but a single tube functioning as both detector and oscillator rather than the customary separate detector and oscillator tubes heretofore employed. This tube is termed the "autodyne" tube, whereas the separate oscillator is generally called a "heterodyne" tube. From this the derivation of "Superautodyne" follows logically. The entire circuit is still of the "supersonic" type, since the frequency of the incoming signals is changed to that of the long-wave intermediate R.F. amplifier.

The circuit of the Superautodyne is shown in Fig. 1. The first tube, from the left, is a combination detector-oscillator, connected in a balance bridge circuit. The next two tubes are the two intermediate frequency amplifiers, functioning at sixty kilocycles, and feeding into the second detector, and then into the customary two audio amplifiers.

Autodyne Frequency Changer

The first portion of the circuit that appears to be radical is the autodyne frequency changer, the circuit of which may best be considered when isolated in Fig. 2. The problem which has been satisfactorily solved here is the prevention of the oscillator section of the circuit from reacting upon the loop or antenna circuit. This is somewhat difficult, since the two circuits must be arranged to feed into the same tube, which must oscillate at one frequency and receive at another, the actual separation of these two frequencies being but sixty kilocycles throughout the broadcast range. In terms of wave-length, the oscillator must be operated at ten meters away from the loop circuit at 200 meters, and about sixty-five meters away at 550 meters in order to produce the necessary beat for the long-wave amplifier.

The solution of the problem by the use of a bridge circuit is due to a Signal Corps engineer, Jackson H. Pressley, and is very effective. Condenser C1 tunes the oscillator grid circuit, made up of coils L2 and L3, which are really a con-

tinuous winding tapped at the center. This circuit is caused to oscillate by means of the tickler, L1, coupled inductively to L2, L3 in the usual fashion. The grid condenser and leak R1, C3, aid detection, but do not interfere with the oscillator circuit. The loop or antenna circuit, represented by B1, B2, tuned by condenser C2, is connected to the mid-point of L2, L3 and at the joint between CX and CX. If we assume a condition of balance to exist between what may be considered the bridge elements, L2, L3, CX, CX, then voltage induced into this circuit from B1, B2, C2 will divide equally across the arms of the bridge, all going to waste except the voltage drop across condenser CX, across which is

cept for the single point brought out above, viz., that the incoming signal is divided and only a small portion used to cause detection. Since the detecting efficiency of a tube is proportional to the square of the applied signal voltage, it is vitally important that maximum potential be delivered to the tube terminals. How, then, is the apparent deficiency to be made up, since in the autodyne circuit less than half the signal voltage is applied to the tube, the balance being lost in the bridge?

Use of Regeneration

That this efficiency is made up is evident in a comparison of the autodyne frequency changer with a standard sep-

Panel view of the six-tube Superheterodyne receiver, which is remarkably compact, being but 18 inches in length.

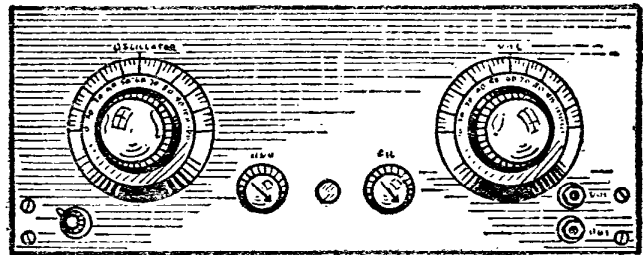

connected the tube's grid and filament. Further, since the loop circuit is connected to the bridge circuit at points of neutral potential, the bridge or oscillator circuit will not react upon the loop system.

With this arrangement, radiation due to the oscillator energy feeding into the loop circuit is automatically eliminated, since the system is so balanced that this cannot occur, unlike the usual "super" circuit where a separate oscillator feeds directly into the detector grid circuit. With a properly designed super, radiation at its worst is not a very serious problem, however, since the oscillator-to-loop coupling is, for best results, so loose as almost to preclude radiation from the loop antenna system.

So far this system looks excellent, ex-

arate detector and oscillator frequency changer, for the signal strength is equal from either system, and frequently in favor of the autodyne. The actual manner in which this occurs appears to be due to regenerative amplification caused by the tickler, L1, the original purpose of which was to cause the bridge to oscillate. However, at the same time as it accomplishes this, it feeds a portion of the signal energy back into the bridge circuit where it reinforces that portion of the signal in the bridge circuit used for rectification, resulting in an even stronger signal than would at first glance be expected from the system.

Were this regenerative amplification to be carried out to the limit, it would be necessary only to feed the signal energy in the plate circuit back into the loop circuit directly by means of an additional tickler in series with L1, but coupled to the loop or antenna coupling coil at B1, B2. The result of such an arrangement, carefully carried out, is a tremendous increase in the sensitivity of the receiver as a whole, as well as an increase in selectivity. This latter condition is due to neutralizing, in the usual fashion, the loop circuit resistance by regeneration, a condition which does not occur in the original balanced circuit of Fig. 2, since the loop circuit is so balanced as not to react or be reacted upon by the oscillator circuit. Hence, any regenerative amplification obtained in a balanced condition is merely through the reinforcing of that portion of the original signal in the bridge circuit utilized for rectification.

Having decided to use regenerative amplification in the autodyne, we see that a second tickler is necessary, or some other means of feeding the signal in the plates circuit back into the loop circuit. A simple method at once presents itself—a slight unbalancing of the bridge, al-

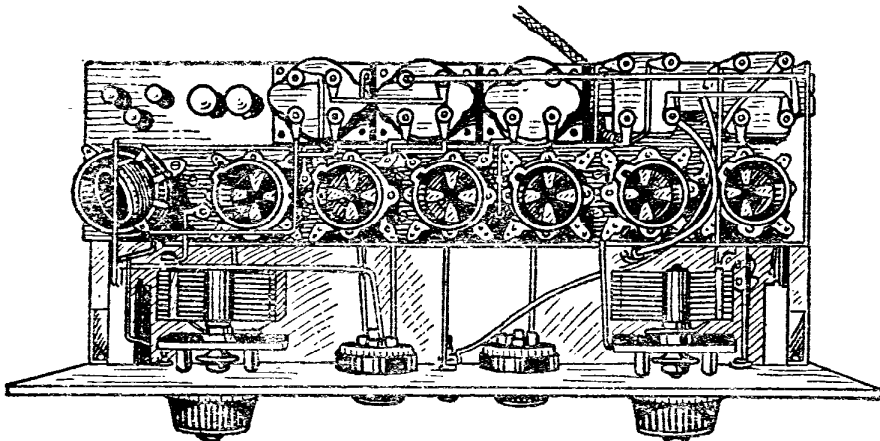

This top view of the receiver shows how the gang vacuum tube sockets are placed in relation to the transformers on the shelf.

lowing a portion of the signal energy feed from L1 into the L2, L3, CX, CX circuit to get into the loop circuit. Of course, along with this comes a portion of the oscillator energy, but it is indeed a simple matter so to adjust one of the balancing condensers, CX, CX, that just the required value of unbalance be obtained.

This results in sharpening up the loop tuning condenser and considerable strengthening of the received signal, at the expense of a slight (but entirely negligible) tendency to radiate. The tuning, as a whole, is broadened slightly, due to reaction of the various circuits, but this is easily controlled by one of the balancing condensers, and is rather desirable, since the system is astonishingly sharp when perfectly balanced.

The only other unusual feature about the Superautodyne illustrated is the intermediate amplifier, which uses but two intermediate stages rather than the conventional three. This is made possible by the use of exceptionally efficient intermediate transformers, operating in a highly regenerative condition. This two-stage amplifier gives practically the same over-all voltage gain as could be obtained from three stages, though it would be possible to obtain proportionately the same results from any good transformers.

The Oscillator Coupler and General Assembly

The oscillator coupler may be made by winding two sections separated 1/16 inch on a 2 1/4-inch tube, each section contain-

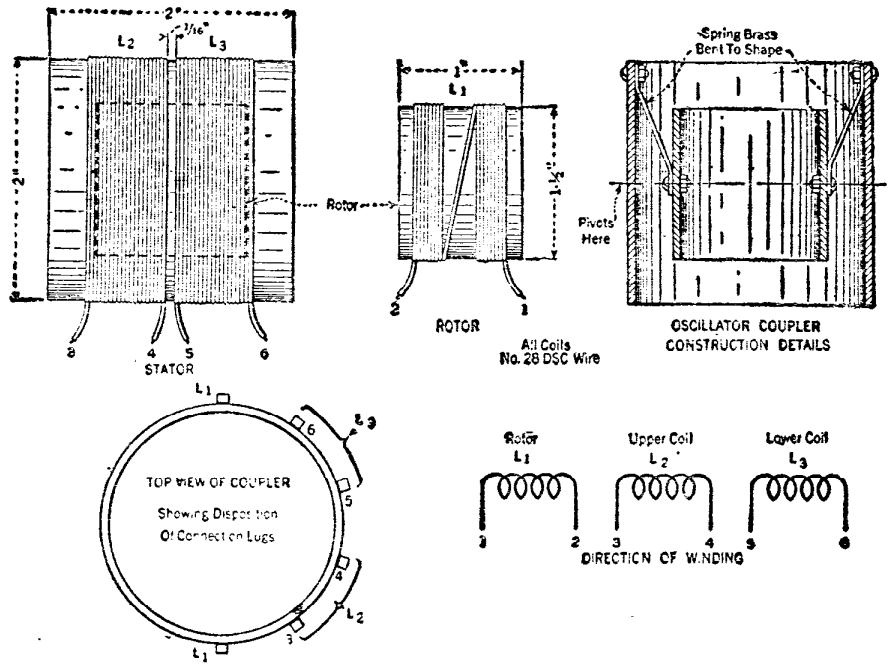

Fig. 3. Constructional details of the oscillator coupler. These plans should be carefully followed to obtain maximum efficiency.

In wiring the receiver, a well-tinned iron should be employed in conjunction with resin-corc solder. A small amount

carefully bent and cut to proper length before any attempt is made to solder it in place. A long piece of bus-bar should not be soldered to a lug and then bent and twisted until it reaches the other lug to which it is to be soldered. Each piece should be bent to fit properly, cut to size and then soldered in place.

Connections

The "A" battery should be connected to its lead, one tube inserted in a socket, switch closed, and rheostat R4 just turned on. If the tube lights, it should be moved from socket to socket to see that all "A" connections are correct. The positive battery lead should then be connected to the B-45 and B-90 posts. If the tube lights, the wiring or assembly is faulty and should be checked. The tube should light only when the "A" battery is connected to the "A" leads.

The remaining batteries may be connected and the loop leads run to posts B1, B2 and B3. If the loop is spiral, B1 goes to the outside lead, B2 to the center tap and B3 to the inside end. Any standard loop may be used.

The tuning is quite simple. The tubes should be adjusted to proper brilliancy by means of the rheostat, and the poten-

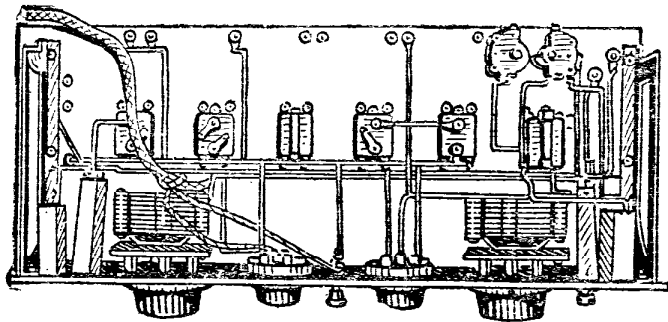

The under side of the shelf that supports the gang tube sockets and the intermediate and audio frequency transformers. This method of arranging the instruments makes for short wiring.

ing 28 turns of No. 28 D.S.C. wire. The rotor coil also consists of 28 turns of the same size wire on a 1 1/2-inch tube, rotatable within the stator tube.

Constructional data on the intermediate transformers and filter may be found in Fig. 3. It is suggested, though, that unless the builder has adequate measuring facilities that he purchase these already tested and matched.

of paste may be used on each connection if desired, but not on any of the fixed condensers. Here, connections may be soldered to lugs or to the condensers directly.

Only two connections can be put on the panel alone. These are a connection between the rheostat and potentiometer and one between the potentiometer and S1. Busbar should be used, straightened,

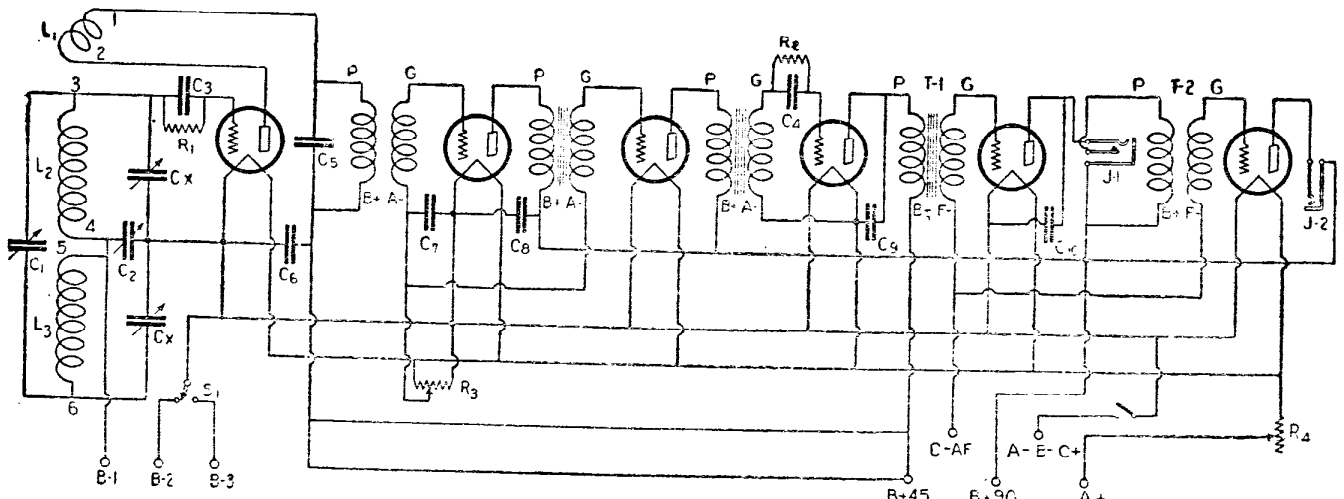

Fig. Circuit diagram of the six-tube Superheterodyne receiver. The first tube on the left is the combination detector-oscillator, then come two tubes used as intermediate amplifiers, a detector and two A.F. tubes.

tiometer set just to the positive side of that adjustment where a "plunk" is heard as it is turned to the right or negative side. When it is properly adjusted, no squeals at all will be heard—when improperly adjusted, many will be heard. Reference to the tuning chart will show approximately how the dials should be set for different wave-lengths.

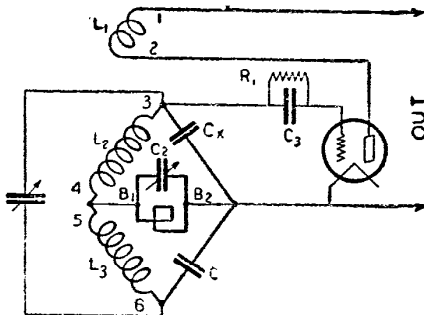

Fig. 2. The autodyne frequency changer, part of the circuit which oscillates at one frequency and detects at another.

Balancing is done by first setting both small condensers all the way in. Then, as the tuning dials are rotated, clicks will be heard. If one of the balancing condensers is turned out, a point will be found where no clicks can be heard. The condenser connected from grid to filament will generally have a low setting, while the other balancing condenser will be all the way in. Once the receiver has been balanced, it should be tuned for several days and then gradually unbalanced by adjusting one of the condensers (CX). If this is done on a weak station, an increase in signal strength will be noticed. If the set is too far unbalanced, however, the selectivity will suffer.

Construction

The practical construction of a receiver embodying the Superautodyne circuit, with either a balanced or slightly unbalanced bridge circuit, is extremely simple and will readily be understood by reference to the various pictures and diagrams accompanying this article. The actual list of parts necessary is given below. They may be of standard manufacture, but should be carefully selected to conform with the general specifications, since for the design illustrated the electrical and mechanical requirements have been very carefully worked out to give best results.

Tools required: 1 hand-drill with drills and countersink; 1 soldering iron with resin-core solder and non-corrosive paste; 1 side-cutting pliers; 1 screw-driver, hammer and centerpunch.

As soon as the material has been procured, each item should be carefully examined to see that all screws and nuts are tight, and lugs placed as shown in the illustrations, so that those on the various instruments will point in the best directions for short leads. Socket springs should be bent up to make good contact with the tube pins. Condenser bearings should be adjusted to give the desired tension.

The front panel may be laid out with the aid of a rule and scribe, after which the hole locations should be punched with a centerpunch or nail, and a hammer. After drilling the holes, the panel may be grained with fine sand-paper and oil, rubbing in one direction until the original polished finish has disappeared. After wiping the panel off with alcohol, indicating marks for the dials may be scratched as indicated and filled with Chinese white. The sub-panel should not be grained.

2 (C1, C2)	.0005 condensers.
2	4-inch moulded dials, vernier type preferably.
1 (R4)	6-ohm rheostat.
1 (R3)	240-ohm potentiometer.
3 (B1, B2, B3)	Insulated top binding posts.
1 (J2)	1-spring jack.
1 (J1)	2-spring jack.
1 (C5, 211)	60 K.C. filter with matched tuning condenser.
2 (210, 210)	60 K.C. matched intermediate transformers.
1 (L1, L2, L3)	Coupling unit.
1	6 gang 199 or 201A socket shelf.
2 (T1, T2)	3½:1 audio transformers.
2 (C7, C8)	.5 mfd. by-pass condensers.
2 (C3, C4)	.00025 mica condensers with leak clips.
2 (C9, C10)	.002 mica condensers.
1 (C6)	.0075 mica condensers.
2 (Cx, CX)	.000025 balancing condensers.
1 (R1)	.25- or .5-megohm leak.
1 (R2)	2-megohm leak.
1 (S2)	On-off switch.
1 (S1)	S.P.D.T. switch.
1	5-lead color cable.
1	Pair shelf brackets.
1	Panel 7x18x¼ in.
29	6/32 R.H.N.P. ¾-inch machine screws.
2	6/32 R.H.N.P. 1½-inch machine screws.
31	6/32 N. P. nuts.
10	lengths bus-bar.
25	soldering lugs.

How to Construct the Hetro Five

(Continued from page 19)

50 on the dials will give the most satisfactory volume. Other places may be tried, but the best amplification will be with the condenser plates halfway out.

Completion of this task should be followed by another process of adjustment with R1 and R2, so that our set is working at its best. Then the three panel rheostats are adjusted until a spot is found where good volume is coming through the loud speaker. Of course, care should be taken not to burn the tubes above their rated filament current.

It will be found that the set can be so adjusted that the detector rheostat will act as a volume or regeneration control. The detector tube, it will be noted, can be burned at a very low voltage without impairing volume. The same is true with the oscillator and R. F. tubes. Here it might be well to say that if the maximum is expected from the set 201-A tubes should be used throughout.

After the set has been adjusted to satisfaction, it will be noted that some stations, especially those near the receiver, will heterodyne the station which it is desired to pick up. But this occurs at only one of the two places that a station can be picked up on the oscillator dial, the fact that a station comes in at two places on this control, being an advantage rather than a detriment.

What Set Will Do

Now a word as to what our "Hetro Five" will actually do. It not only will separate the Chicago locals, which is an accomplishment in itself, but it will reach into the outside air and bring 'em in on the loud speaker. While this is being put down, the writer's "Hetro" is bringing in WIBO on the loud speaker on four tubes, with WMBB, which is a scant half mile away, going full blast. And the antenna in use is exceptionally large. In addition, during the month of August—Also with WMBB going—WPG at Atlantic City was copied on the loud speaker, using all of the tubes.

Of course, as with any set, the antenna system governs to a large extent the volume and selectivity. But with the "Hetro Five," lengthening the antenna gives a greater ratio of increase in volume over drop in selectivity than does almost any other type of five-tube set. However, if the fan desires good volume with plenty of selectivity, the recommended antenna length would be 75 feet. And if the greatest selectivity possible is desired, he can resort to a loop, which, while it will not bring in the distance that an outside aerial will pick up, will log enough DX under favorable conditions to thrill almost any fan.

If the builder has used care in his construction along with good parts, he should not encounter untold difficulties in making the five-tube family perform to the point where the "Hetro Five," using an outdoor antenna, will step along with any multi-tube Superheterodyne, using a loop aerial. Not only that, but it is in a class by itself when compared with a tuned radio-frequency set, using the same number of tubes.

Having thus unburdened in an effort to aid the humble fan in his pilgrimage along the path of better radio, the writer desires to wish you all the luck in the world, and if the "Hetro Five" doesn't hurdle all of the obstacles it should, it's just up to you to make it forget its bad habits.

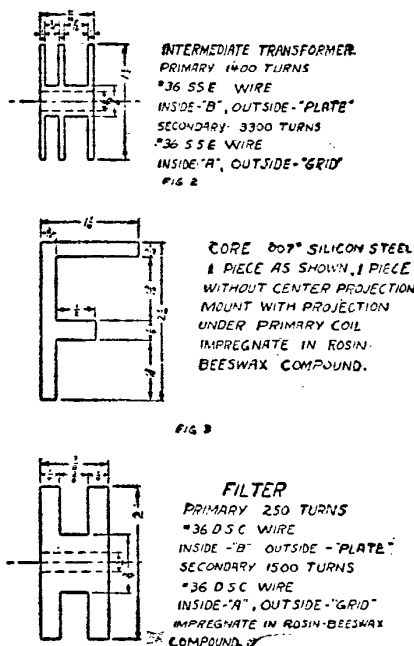

The Midget Super

A Seven-Tube 45,000 Cycle Superheterodyne in Kodak Size Employing U.V. 199 Tubes

THE average conception of a Superheterodyne receiver pictures an outfit 2 ft. long, 7 or more inches in height and at least 8 in. deep. We have been told that to cram all the parts of so elaborate a circuit as the super into a smaller space than the conventional arrangement would be to invite all kinds of trouble from howling due to coupling between transformers to broad tuning resulting from the feeding of oscillator current through the various wires of the set.

While this claim is true to a certain extent, much of the apparatus can be placed in very close proximity if care is taken in shielding the intermediate transformer group and in keeping the field of the oscillator coil at a considerable distance from the intermediate amplifier.

With the latter idea in mind, W. P. Brush, a radio experimenter, constructed a portable set which occupies a minimum of space, weighs only 7½ lbs. with the vacuum tubes, and yet does not have any of the troubles predicted.

Clinton Osborne describes this set in *Radio*, San Francisco, Cal., giving full details for its construction as follows:

The Midget Super described herewith employs the circuit of the "Best Superheterodyne," which appeared in *Radio* the first part of this year. In the pictures herewith only the actual receiver is shown. It may be mounted in either a cabinet for home use or a leather carrying case with a collapsible loop, the latter outfit weighing about 25 to 30 pounds complete with small size "A" and "B" batteries. For home use this set is ideal when installed in a desk or small table.

A 3/16 in. panel of bakelite 5¾ in. by 11 in., on which all of the necessary

ness and excellent arrangement of the various sockets, transformers and condensers, the vacuum tubes showing admirably the relative size of the set. The constructor can readily follow the layout from these photos, using the parts as described in the following.

a full size drawing of the panel layout should be drawn on a piece of paper to the dimensions given in Fig. 3. Paste the template on the panel, and with a center punch mark the centers of the holes directly through the paper.

The first named parts in the list are

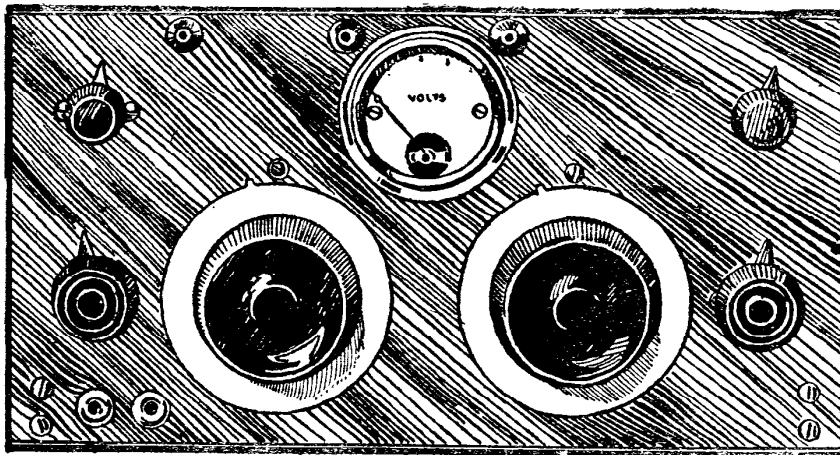

The front panel view of the midget super. Note how close the two variable condenser dials are located and the other controls surrounding them.

Description of Parts

The accompanying table gives a complete list of parts used in building the set, together with a list of parts that might also be used, if the constructor prefers to build a larger or standard size super. No specific recommendation for any of these parts is implied, the list being made up from those most generally

those used in the Midget set, and if other parts are used, the panel template will not be correct. Where flat head machine or wood screws are used the holes in the panel should be countersunk.

The intermediate frequency transformers should be such as to give good amplification at 45,000 cycles, and the input impedance of each primary should approximate the output impedance of the UV-199 or C-299 tubes, an important consideration. The iron core construction of the untuned stages limits the stray field and permits of close spacing, without shielding. The tuned transformer should be of the same type as named first in the list herewith if the set is to operate with the fixed condenser specified in the circuit diagram. If another tuned transformer is used, it would be best to use a fixed condenser of the value specified by the manufacturer of the transformer in the circular accompanying the apparatus.

The various fixed condensers should be of standard manufacture.

For providing the various negative grid potentials the Burgess No. 5,540 7½-volt "C" battery is specified because it has enough taps to accomplish the desired results.

For those who wish to use an antenna with this set, the circuit diagram showing the additional apparatus needed is given herewith. The coupler consists of a standard 180-degree vario-coupler, similar to the oscillator-coupler used in the receiving set. The antenna circuit should consist of a .0005 mfd. (23 plate) variable condenser, not necessarily of the vernier type, a 75-turn honeycomb or other compact inductance coil, and the rotor of the coupler. In order to prevent the reception of a large amount of noise, static and interference, it will be necessary to operate the antenna coupler at minimum coupling, doing most of the tuning with the antenna series condenser. It would be well to

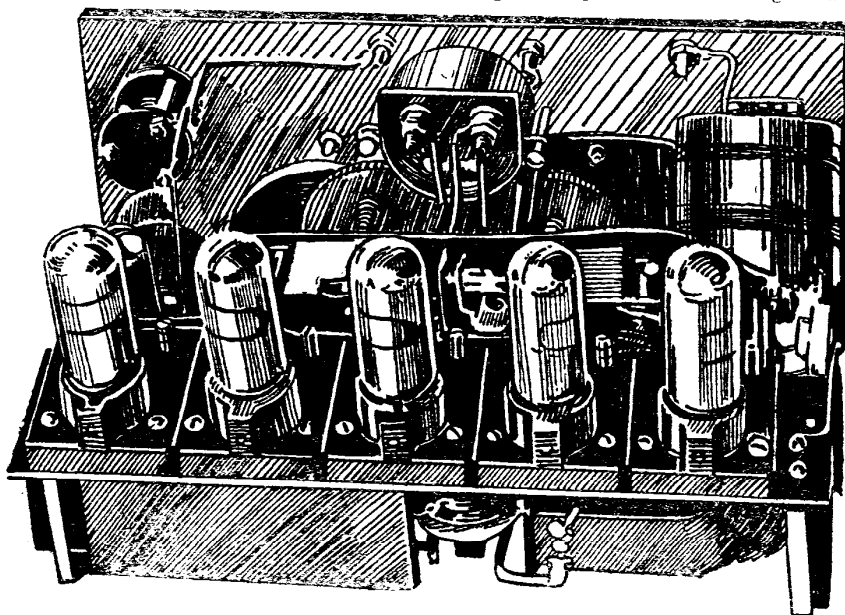

Rear view of the completed Superheterodyne arranged in compact form. Only five of the seven tubes can be seen as the remaining two are mounted between the panel and the shelf in the back of the set.

panel apparatus could be crowded, is used, and the arrangement of the rest of the equipment is made to conform with the size of the panel. The illustrations give an accurate picture of the compact-

available at radio stores. There are undoubtedly other parts, not here listed, that will suffice.

To facilitate laying out the panel drilling and the apparatus on the baseboard

shield the inside of the box containing the antenna tuner so as to increase the selectivity. Many have tried grounding one side of the loop antenna, with good results, although the directional properties of the loop will be somewhat impaired. However, for remote districts where local interference is not known, this would certainly improve the signal strength on distant stations.

Construction of Parts

Many readers may desire to construct as much of the apparatus as is possible, and it is for their benefit that data on the construction of the oscillator coil and 45,000 cycle amplifying transformers are given.

The oscillator coil consists of 70 turns of No. 26 D.C.C. wire, wound in two sections of 35 turns each, on a 2¼-in. tube. The grid coil is 20 turns of No. 26 D.C.C. wire wound on a 1½-in. tube, and arranged to rotate within the oscillator coil in a manner similar to the rotor of a 180-degree coupler. Pigtail leads should be used for the rotor connections.

The untuned transformers should be wound as follows: Turn out three hardwood spools, each with two slots for the windings, one slot being ¼ in. and the other ½ in. in width. The principal dimensions of the spools are given herewith. A hole ¼ in. in diameter should be bored in the center of the spool, for the core. The primary winding should consist of 450 turns of No. 30 D.S.C. wire, wound in the ¼ in. slot. No particular order should be observed in winding the coil, the wires being placed in a haphazard manner to reduce the distributed capacity effects. The secondary winding should be 2,100 turns of No. 36 single silk wire, wound in the ½ in. slot. For the core material, use either a bundle of fine iron wires, such as No. 36 gauge, or

a bundle of flat strips of silicon steel, not over .003 in. in thickness. Ordinary heavy transformer iron or silicon steel will not do. The thinner the laminations the better the transformer will be. Small lugs should be provided for terminals, the inside primary lead going to the plate, outside primary to the "B" battery, inside secondary to the filament and outside secondary to the grid, in each transformer.

The single tuned transformer is wound on a spool, turned from seasoned hardwood with flange ¼ in. in width, a diameter of 2½ in., a hub of 1 in. and a slot ½ in. in diameter. On this spool wind 250 turns of No. 30 D.C.C. wire, in a haphazard manner. Place a layer of insulating paper over this winding, and wind on 1600 turns of No. 36 single silk or enameled wire, for the secondary coil. If this transformer is used in the circuit, the primary condenser should be .005 mfd., and the secondary condenser

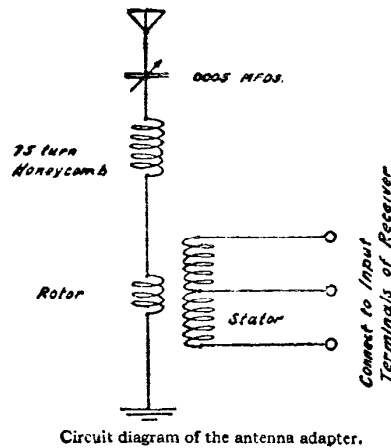

should be omitted. The four leads from the windings should be terminated in a manner similar to that described for the untuned transformers.

Mounting Assembly

Two Remler condensers are mounted at 90 degrees from their usual position, in order to take up as little room as possible when at their minimum capacity position. As the dials furnished with the condensers are 4 in. in diameter, it was necessary to cut them down to 2½ in. each, the cut being made with a hack saw in order to retain the small piece of metal used on each dial as a stop. The voltmeter was selected because of its small size, fitting above and between the two air condensers. On each side of the condenser group is a small rheostat, each condenser end plate being filed away for ⅛ in. in order to make room for the rheostats.

The oscillator coupler is mounted at the upper left end of the panel and the feedback condenser at the upper right end. The loop terminals are brought out at the top of the panel at points where

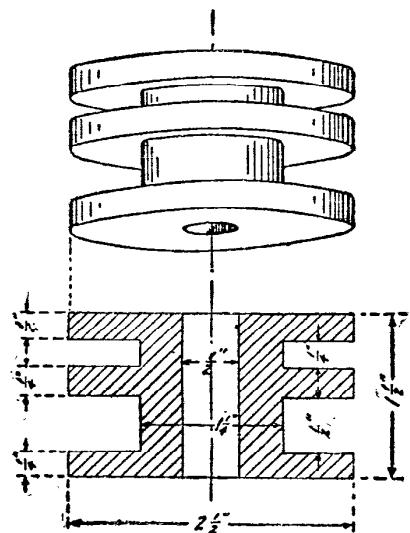

Spool dimensions for untuned transformer.

PARTS FOR THE MIDGET SUPER

3 Untuned I. F. Transformers, Remler 600—All-American, Baldwin-Pacific Branston, Jefferson, Phoenix, Receptrad, Silver-Marshall.

1 Tuned I. F. Transformer, Remler 610—All-American, Baldwin-Pacific, Branston, Jefferson, Phoenix, Receptrad, Silver-Marshall.

1 A. F. Transformer (6:1 ratio preferred), General Radio—Acme, All-American, Amertran, Coto, Dongan, Ford Mica, Jefferson, Kellogg, Modern, N. Y. Coil, Peerless, Precise, Premier, Samson, Stromberg-Carlson.

5 Phone Tip Jacks, 2 for loud speaker and 3 for loop (small binding posts may be used instead of the latter).

1 Oscillator Coupler, Remler 631—Baldwin-Pacific, Branston, Phoenix, Receptrad, Silver-Marshall.

2 Rheostats, General Radio—Allen-Bradley, Amsco, Carter, Central, Cutler-Hammer, Erla, Filko, General Instrument, Kellogg.

2 Variable Condensers, Remler 631—Acme, Allen-Bradley, American, Brand, Bremer-Tully, Bruno, Cardwell, General Instrument, General Radio, Heath, Marco, National, Signal, Silver-Marshall, U. S. Tool.

1 Midget Condenser, Chelton 860.

5 Small Tube Sockets, Remler 399—Benjamin, Amsco, Chelsea, Cutler-Hammer, Frost, General Radio, Heath, Marco, Silver-Marshall.

1 Voltmeter, Hoyt.

2 2 mfd. Fixed Condensers, Kellogg 62; 1 .006 mfd. Fixed Condenser, N. Y. Coil; 2 .0025 mfd. Fixed Condensers, N. Y. Coil; 1 .00025 mfd. Fixed Condenser, Dubilier 640; 1 .0005 mfd. Fixed Condenser, Dubilier. With grid leak mounting.

1 Grid Leak, Daven, Durham, Electrad.

1 "C" Battery, Burgess 5540—Eveready.

1 Nazeley Suportena Loop.

1 Panel, Bakelite—Celerin, Pantasote, Radion, Spaulding.

1 Baseboard.

the connecting wires would be shortest.

The secret of success in the compact arrangement is the placing of the oscillator and first detector tubes at opposite ends of the panel. The oscillator tube is mounted directly underneath the oscillator coil and adjacent to the oscillator condenser. The first detector tube is mounted under the main filament rheostat.

A pair of brackets made from flat brass strip, as shown in Fig. 1, support the bakelite shelf at the rear of the set, on which are mounted the remaining five tube sockets, the transformers and miscellaneous apparatus. The oscillator and first detector sockets are fastened to the bottom of the brackets of each end of the panel. The bakelite shelf is 2¼x11 in. of 3/16 in. bakelite, the five sockets completely covering the top of the shelf. Underneath the shelf are mounted the three intermediate frequency transformers, crowded together and shielded from each other by a copper sheet, all shields being tied to the negative "A" battery.

The tuned transformer is removed from its bakelite case and mounted between the intermediate group and the audio transformer, which can be seen clearly in the illustration. Back of the intermediate transformers is mounted a 1 mfd. by-pass condenser, of the ultra-thin type.

The schematic circuit diagram is

shown in Fig. 2. A 6 to 1 ratio transformer is used, in order to obtain as much voltage amplification in the audio stage as is consistent with fair quality.

In order to localize the oscillator current as much as practicable, a small radio frequency choke is placed in the oscillator plate battery lead, between the oscillator coil and the point in the "B" battery lead where battery voltage is supplied to the other parts of the set. This choke may be made by winding 250 turns of No. 32 cotton covered wire on

Some difficulty will be experienced in wiring the set, as the arrangement of parts is very cramped. It is well to wire up the vacuum tube circuit, including the oscillator and 1st detector tubes,

before fastening the shelf and bracket assembly to the panel. The final connections to the panel apparatus can then be made without much trouble. Anyone never having built a multi-tube set before would do well to try something else first, as full detailed working drawings of the set cannot be furnished here, and the successful construction of the outfit rests with the mechanical ability of the worker.

No claims for great selectivity or distance are made for this outfit, and for city use, a larger layout is more desirable, but for reception in the country, where powerful stations are somewhat distant, it has no peer. Successful reception of stations on the loud-speaker, over a distance of 2000 miles at night, using a portable loop antenna, has been had with this set and there is every reason to believe that anyone handy with tools and familiar with common radio circuits can do as well.

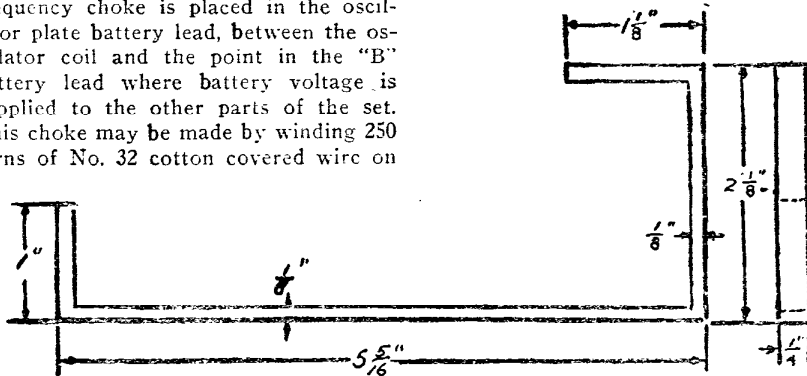

Fig. 1. Details of the bracket pieces which are fixed to the panel for supporting the shelf on which five of the vacuum tube sockets are mounted.

an ordinary wooden spool such as is supplied with sewing thread. The wire may be wound jumble fashion, and the spool can be mounted next the audio amplifier tube, as shown in the picture.

Looking at the rear of the set, the tubes mounted on the shelf are as follows, reading left to right: 1st, 2nd and 3rd intermediate amplifiers, 2nd detector and audio amplifier. This method brings the output of the set to a pair of phone tip jacks mounted on the front of the panel, there being no arrangement for plugging in on the detector tube.

The panel layout is shown in Fig. 3, the voltmeter hole being cut for a Hoyt instrument. No drilling holes are shown for the mounting screws of the rheostats, as apparatus other than that shown in the pictures may be used.

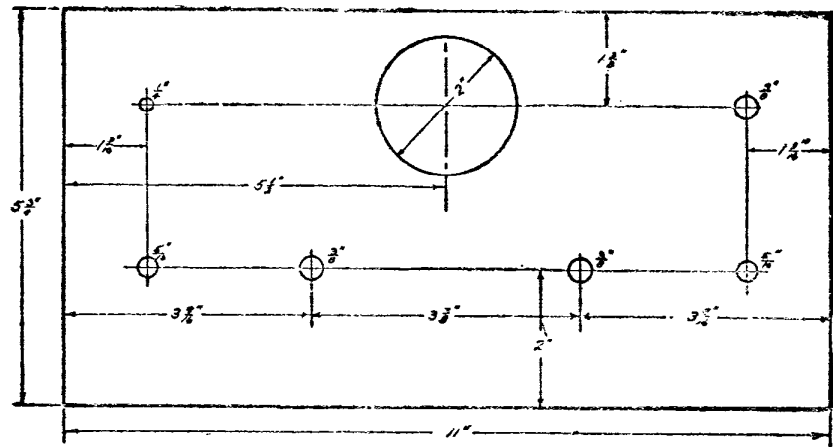

Fig. 3. Panel layout of the midget super. It will be noted that a two-inch hole is drilled in the center for a voltmeter. If the constructor desires he can omit this instrument.

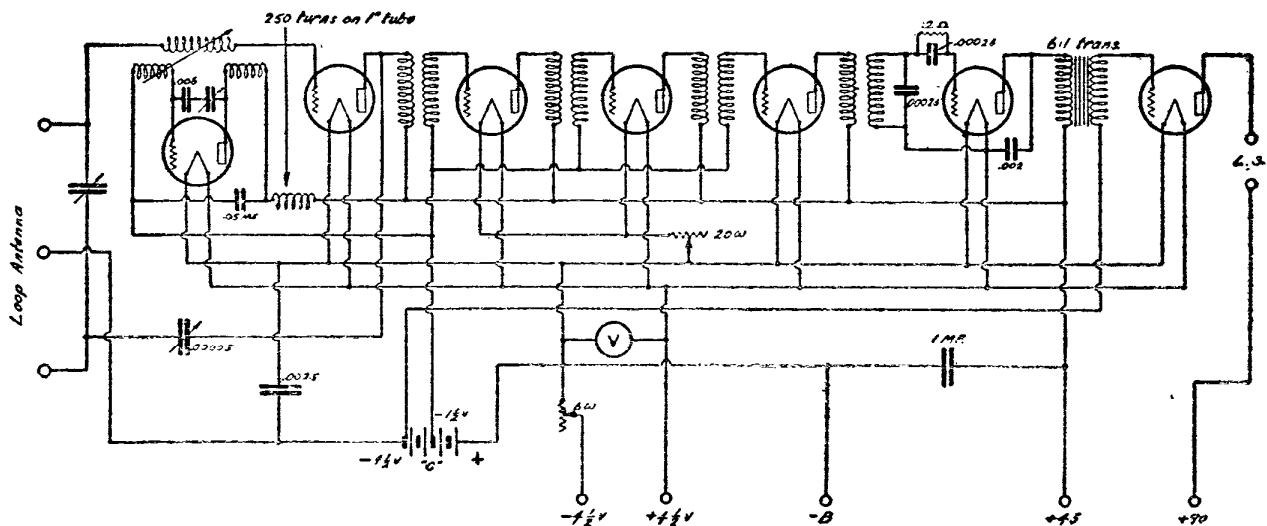

Fig. 2. The wiring diagram of the set in schematic form. The battery leads brought out through the rear by means of colored wire cables or lengths of lampcord. The three loop terminals are fixed to the top of the panel and loud speaker to phone tip jacks.

A Powerful Six-Tube Superheterodyne

Can Be Readily Assembled at Home
from Standard Parts

A LONG with the increased power of broadcast stations and a decision of the Department of Commerce to turn loose the big broadcasters to down interference by their own increase of power, sets of the selectivity of the Superheterodyne are quite the vogue.

The beauty of building or owning a super is that one may have the satisfaction of knowing that one's set will give as much selectivity, clarity and volume as any.

These, in the order above mentioned, are what one may expect from a well constructed set.

The set described and illustrated herewith is one which recently appeared in the *St. Louis Daily Globe-Democrat* and is similar in principle and theory to the standard Superheterodyne circuit.

It differs slightly, however, in a few minor details, which make it more desirable from a standpoint of economy, simplicity and portability.

It will be noted upon the circuit diagram that two stages of medium frequency amplification are used instead of the customary three. The reason for this is that a third stage of medium frequency amplification does not sufficiently improve the sensitivity to warrant its use in this set—bearing in mind

modest current consumption. With all six tubes lighted to proper brilliancy, the current drawn from the "A" battery is only about thirty-five hundredths (.35) ampere. Six ordinary 1½-volt dry cells, connected in two parallel groups of three

and is not prepared to suggest substitutions. The numbers refer to types.

Necessary Parts

Before studying the construction of this "super" it would be well to look

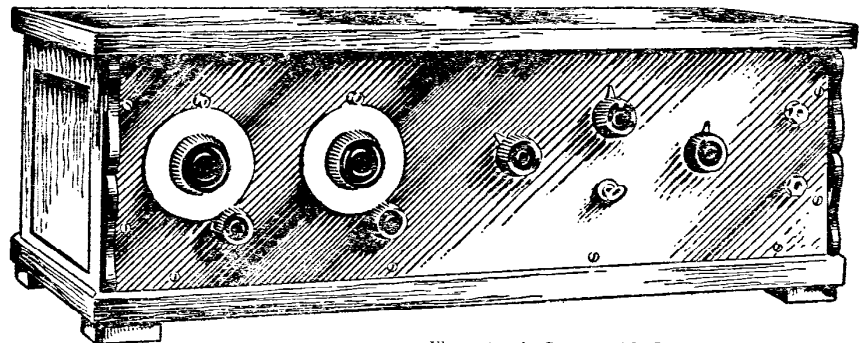

A front view of the completed receiver showing the tuning and oscillator dial at the left and the rheostats and potentiometer at the right.

cells, connected in series, will provide current enough for over a hundred hours of intermittent operation.

Perhaps the most important considera-

over this list of parts, which are necessary to build the set and note the code references to the instruments as they are mentioned in the instructions.

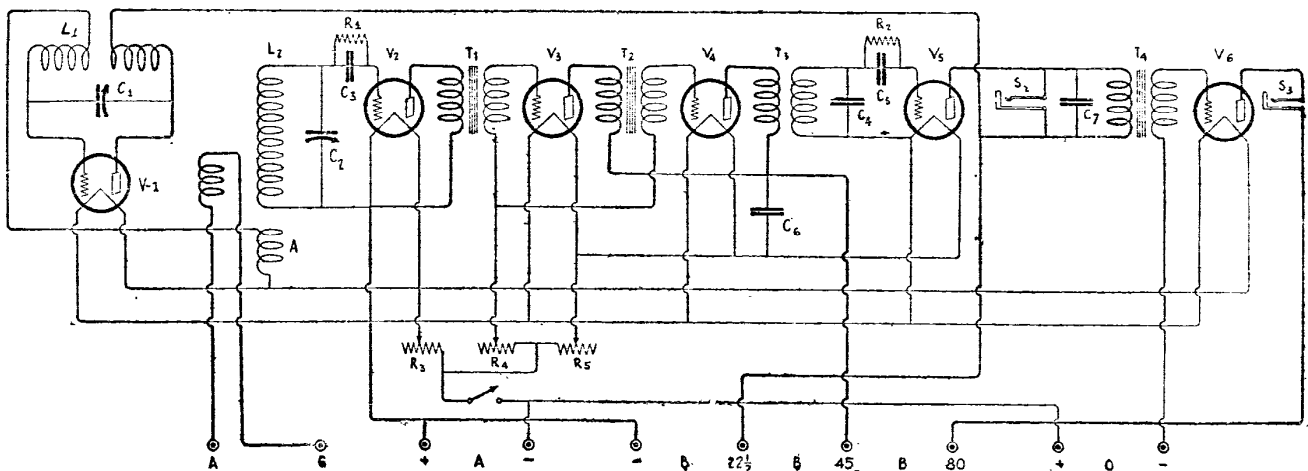

Wiring diagram of the powerful six-tube Superheterodyne. The constants of the circuit are given in the list of parts for the set.

that economy, simplicity and portability are the advantages which this "super" are supposed to have over the average. Then, too, from a standpoint of performance, it has been proven that two stages of intermediate frequency excel three for quiet operation, especially when interference is prevalent.

Antenna System

It has been found by experimenting with various types of antenna systems that the short antenna of 15 or 20 feet of No. 18 wire gives far better results than does a loop, and is practically as portable, since it may be erected most anywhere with very little difficulty. Although a loop is not recommended for this set, it may be used with a fair degree of success.

Small Battery Expense

Another advantage which will be appreciated by the operator is its very

tion from the viewpoint of economy is the small consumption of current from the "B" batteries. This has been reduced to the barest minimum without sacrificing efficiency. The six tubes consume only about nine milliamperes in the plate circuit, as compared to twenty-five to thirty-five mills consumed by other "supers".

One stage of audio amplification, provided the correct transformer is used, is sufficient to give comfortable volume on all signals with the "super". A second stage is very seldom necessary or satisfactory, unless a separate "B" battery is used.

Choice of Parts

The reader will note that all the principal parts used in this set are General Radio. There are, of course, other parts which may be used, but the writer in building this set could not very well try out all of the countless combinations,

- 2 .0005 Mfd. condensers C-1, C-2.
 - 2 271 I.F. transformers T-1, T-2.
 - 1 331 (30 kc) tuned transformer T-3.
 - 1 285 audio transformer T-4.
 - 2 30 ohm rheostats R-3, R-5.
 - 1 200 ohm potentiometer R-4
 - 6 299 sockets.
 - 1 277-C inductance coil L-1
 - 1 277-D coupling coil L-2.
 - 2 dials.
 - 1 condenser .5 Mfd. C-6.
 - 1 battery switch 8-1.
 - 2 open circuit jacks.
 - 2 Dubilier 60-C grid condensers C-3, C-5.
 - 1 2 megohm grid leak R-1.
 - 1 5 megohm grid leak R-2.
 - 1 .0005 Mfd. fixed condenser C-7.
 - 10 Binding posts.
 - 1 Bakelite panel 7x21x3/16".
- A shield is strongly recommended to cover the base of the set and part of the panel that supports the oscillator condenser, C-1. It is important to shield

this instrument in order to prevent body capacity effects.

The cabinet is, of course, up to the builder, but a set of this caliber should warrant a good cabinet, which should cost somewhere in the neighborhood of \$10.

Accessories

- 6 UV-199 or C-299 vacuum tubes,
- 6 dry cells.
- 2 45-volt "B" batteries.
- 1 4½-volt "C" battery.
- Pair good head phones.

Now comes the question of a loud speaker and the writer must leave this entirely to the individual. Speakers vary

jacks one above the other about two and one-half inches apart. Shaft holes for the condensers, rheostats, potentiometer and battery switch should be three-eighths of an inch. Those for the jacks should be fifteen-thirty-seconds of an inch. All other holes can be made with a No. 25 drill.

After the panel is drilled and counter-sunk wherever necessary it should be rubbed down with very fine emery to remove the glossy effect.

Then it should be rubbed with an oily rag to overcome the grayish effect and restore the panel to a smooth satin finish. If the panel is to be engraved it should be done at this point.

The Superheterodyne is one of the simplest sets to wire after the layout is determined. After completing the wiring check it carefully and connect the antenna, ground and batteries. Then try, one tube in all the sockets, turning on each rheostat slowly. By testing in this manner all the tubes will not blow if something is amiss.

Operation

It is usually more satisfactory, when getting accustomed to the set, to use the head phones and tune very slowly, keeping the dials in step. Turn the rheostat, R-3, about half way on, set the arm of the potentiometer on the negative side and increase R-5 until a rushing sound is heard. Then tune slowly until a station is brought in loud and clear.

Much has been written about matching tubes for the "super." This is easily done by interchanging the tubes until the potentiometer can be operated nearest the negative end without oscillation.

The best position for the rheostat and potentiometer will be found after a little experimenting, and these may be left set. The process of tuning then becomes rather a simple one with only two dials to manipulate. To get the best results these dials should be adjusted very slowly and carefully, because the "super" is a very selective and sensitive set.

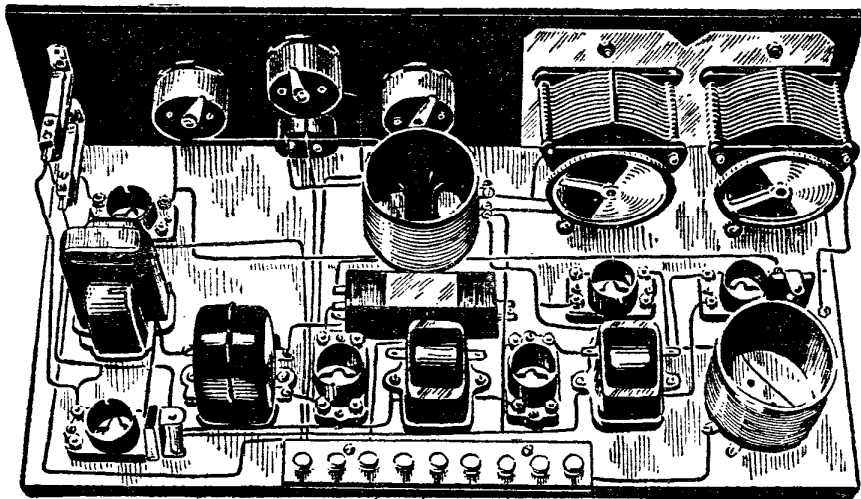

Rear view of the completed six-tube Superheterodyne assembled from standard parts.

widely both in price and quality of reproduction. They should be compared on signals which show up both high and low tones. It is best to actually compare them on the same signal. The new hornless cone types have proven very satisfactory with this receiver.

Constructing the Set

Wind one turn of No. 22 to No. 26 cotton or silk covered wire around the lower end of the coupling coil L-2. This furnishes the coupling between the first detector V-2 and the oscillator V-1. Be sure that this turn is at the ground end of the coil and wound in the same direction as the coil windings. The approximate location on the coil and in the circuit is indicated at "A" in the diagram. In laying out the panel place the condensers close enough to each other so that the tuning dials may be watched simultaneously when the set is being operated.

Place the hole for the shaft of condenser C-2 in the center of the height of the panel and three inches from the left edge as you face the front of the panel. Eight inches from the left edge of the panel center the shaft hole for the oscillator condenser C-1. Four inches in the right of the center of this (L1) shaft hole place rheostat R-3. Two and a half inches further to the right draw a vertical line perpendicular to the bottom edge of the panel and upon the line locate the centers for the shaft holes for potentiometer R-4 and battery switch S-1. The potentiometer may be one and a half inches below the center. Two and a half inches to the right of the above described vertical line drill the hole for the shaft of rheostat R-5. Two and one-half inches from the right edge of the panel draw another vertical line perpendicular to the lower edge of this panel and on this line place the two

Shielding the Baseboard

The next step is to knock out a baseboard 19 inches by 9 inches of ¾-inch stock, preferably soft white wood, since this is easily workable and free from knots. A thin shield of copper should be placed over the baseboard and behind the panel to shield the two condensers, as shown in the illustration. This does away with body capacity effects and serves as a common "A" connection which simplifies the wiring to a great degree.

Mount the apparatus on the panel and place the panel and baseboard together. Then the parts may be mounted on the baseboard without difficulty. The arrangement in the illustration seems to be most satisfactory from a standpoint of ease of assembly and efficiency of operation.

Now you are ready to wire. Probably the best material for this purpose is bus wire of a medium size and reasonably soft, so that if bends have to be straightened out and relocated the wire will not break or crack. The leads from grids and plates should be kept well separated. This actually adds to the efficiency of any multi-tube receiver.

Contrary to general custom, an open circuit jack is used at S-2. The primary impedance of the new General Radio audio transformer is so high that it does not appreciably affect the signal intensity when shunted across a pair of telephone receivers. Consequently the wiring is somewhat simplified by the use of the open circuit jack and the receiver may be used either with head phones, loud speaker or both.

No mention has been made so far of the fixed condenser indicated in the diagram at C-4. This condenser is built into the tuned filter transformer, T-3, and no external capacity is necessary here.

An Improved Laboratory Superheterodyne

(Continued from page 12)

Therefore, it may be well to do away with the regenerative first detector circuit temporarily by reconnecting the circuit as suggested in the circuit diagram. This will render the antenna tuning quite broad, with consequent ease of handling, but at the expense not only of selectivity, but of a considerable degree of sensitivity.

Single Control

Using the non-regenerative first detector connection, the antenna tuning will be broad enough so that if the two tuning condensers are geared together, one knob may be used for tuning, thus simplifying control. This is as practical an arrangement as can be used in any super. The antenna tuning being broad, it is possible to vary both condensers at once, keeping them a uniform number of degrees apart, and yet still obtain the best setting for all waves on both condensers.

In view of the single-control feature, the use of a loop has not been seriously considered. However, it may be used with perfect satisfaction as on any super, by removing the antenna coil and connecting the loop with its inside end to post 6 of the coil socket, its center tap to post 4 or 5, and its outside end to post 3. This assumes a spiral loop, of 18 turns, about 20 inches mean diameter with turns spaced one-half inch between centers. Stranded loop wire should be used—not Litz. For shorter waves, fewer turns will be required—say about eight for the 100- to 200-meter band and about four for the 50- to 100-meter band.

In the case of some standard loops, wound with few turns, it may be necessary to add a turn or two to cover the desired maximum range up to 550 meters.

Everyman's Receiver—The Fenway

By LEO FENWAY

The following article is the first installment of a complete description of this popular Superheterodyne receiver. Here are the instructions for constructing and testing a most important part of the circuit—the oscillator and first detector.

IN the greatest city in the world—New York—as in a myriad of towns and hamlets the comparatively new drama, "How to Build Your Own Radio Set," is being staged by the enthusiasts among radio listeners-in. In all radio dramas the principal characters—the coils, condensers, transformers, tubes—have practically the same roles; but the plot of the production—the circuit—is in a state of continual modification.

The dramatist sets his stage, introduces his characters, and the action goes on in the form of a beginning, a body, and an ending. The radio constructor-dramatist is under the same necessity of visualizing his receiver in successive scenes. If he keeps in mind that these scenes are the basis of his composition, he may feel that he has mastered the most difficult problem of assembly.

The beginning of the properly-constructed radio set-building drama has for its function the presentation of the conditions confronting the builder. What is that condition in the version entitled "Everyman's Receiver—The Fenway." We pause for a moment as the curtain rises on Fig. 1.

A glance shows us that the first act will have the "business" of making the first three tubes function. And immediately the problem confronts us: "How well can we make these three tubes perform—well enough to operate a loud speaker on locals?" We already know that the first rule is a stage of tuned radio frequency amplification with regeneration; the second tube a first detector; the third tube is the oscillator. We realize that if we try the set on all three tubes the oscillator is likely to—in fact, should—"mush" the signals of the other two tubes. Therefore we will build the first two tubes with the oscillator but when the set is tested we will keep the oscillator tube out of the socket.

Constructional Work

The first act of the drama is now under way: after the panel is bored for the arrangement shown in the illustrations (making sure that the center shafts of all instruments turn smoothly) it can be mounted upon the baseboard with nickel-plated wood screws. Two of the cans may now be put in place. The first and third will be held in position by the condensers, but the center can must be at-

tached to the panel with short machine screws, as its condenser (that is the plates) must not touch the can, since the rotor plates are not grounded.

The rest of the characters—or parts—seem to fall naturally into their proper places. It is now perfectly obvious that the main character in Act I is the two-circuit coupler. This should now be prepared, following the specifications given in Fig. 4. Be sure, in winding this coupler, to wind the first twenty-six turns spaced, and all on one side.

The purpose of spacing the first twenty-six turns is to cut down the distributed capacity. Ordinarily, spacing the turns means spacing the metal wire itself; this is usually accomplished by covering the wire with silk or cotton. But such spacing is not enough; as the distance between turns should be about equal to the diameter of wire used.

When the coupler is all wound, test it

all in—set the dials to read 100, then tighten the set screws to the shaft.

Remove the nuts from the binding posts on the sockets and put a soldering lug on every post. Put the nuts back and tighten firmly. Put all the binding posts on the sub-panel and then mount the fuse holder behind the first can. Now mount the A battery switch. The four copper cans must be connected together and grounded on the minus A. The minus of the voltmeter, and the plus of the milliammeter, should be connected to the cans as these two connections are grounded.

Wire Carefully

The first step of the assembly being completed, the parts are ready for wiring. If you use colored wiring you can easily trace the circuits if trouble comes. Solder all connections well; and if you use resin core solder watch out for

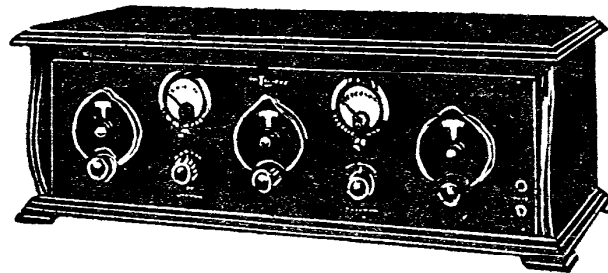

The panel of this Superheterodyne is symmetrical and the meters show the conditions which should be known

for continuity of circuit. It should now be ready for mounting upon the panel. The copper can, four inches square, is placed around this coupler, and the little insulating square (2½x2½ inches) should be attached to the back of this can. Upon this insulator are mounted the tap switch and the three taps. Place the knob of the coupler upon the shaft and the coupler is ready for wiring into the circuit.

The sub-panel, at the back of the set, should not be screwed to the baseboard. Upon this mount the 6-ohm rheostat and the binding posts. (Only the rheostat is to be mounted at this time; the other will come later.) Next mount the double-circuit jack in the top hole on the panel. Now come the three dials. With the three condensers all in mesh—the plates

"resin joints," where the wire is held by resin but no connection is actually made with solder. You really need a good hot electric iron for soldering. Make haste slowly and with all the care and patience at your command, as your wiring will reflect credit or discredit upon you in the form of results.

When the wiring is all completed put the first two tubes in the set, temporarily connect the plate of the first detector to one prong of the double-circuit jack, the B plus 45 volts to the other prong (meaning outside prongs, of course) and the set thus far is ready to be tested.

We are now very close to the end of the first act. The problem which confronted the builder at the beginning is about to be answered. It was, if you re-

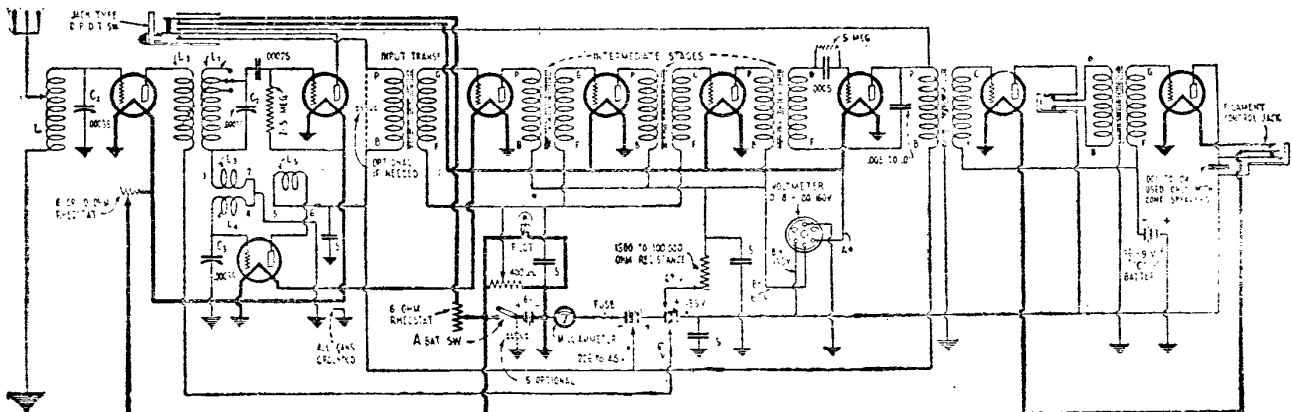

Fig. 1.—By the introduction of the jack switch, shown at the upper left side of the diagram, the receiver can be made to operate on either four or nine tubes.

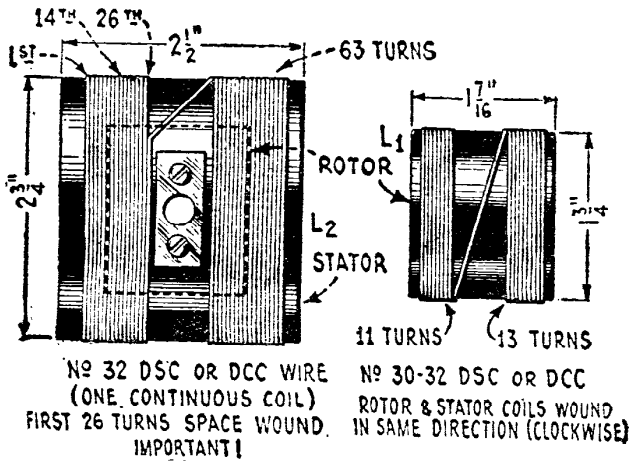
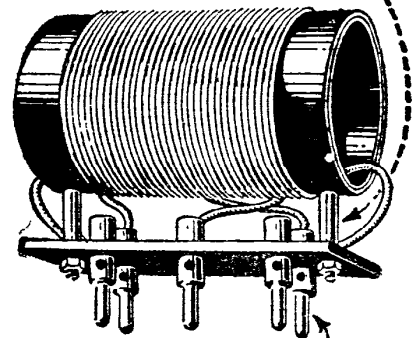

Fig. 4.—On the left are shown the constructional details for inductances, L1 and L2. This variable radio-frequency transformer is the means of connecting the radio-frequency tube to the first detector.

The sketch on the right indicates the manner in which the various coils of the Fenway Superheterodyne receiver are made interchangeable, in order that different wave-bands may be received.

BUSHINGS TO RAISE COIL FROM BASE



CONTACT PLUGS

Have you "hooked-up" a good ground on that first coil condenser?

"After making these tests, break the circuit between the coil and the socket and connect a grid condenser and leak between these two points. Connect a pair of phones to the plate of this socket and to the B battery +45 volts. If that first circuit is working you will be able to hear a local station. Now take the second circuit, and test it the same way. Next, the two circuits combined. Now test the oscillator as you have already tested the first two circuits. Forget that it is an oscillator circuit. Treat it as if it was the first can—the antenna circuit. Here's how you do it: Plug one tip of the phone cord under the plate binding post of the oscillator tube socket, con-

member: "How well can we make the first three tubes perform? Will they operate a speaker with fair volume on locals?" The problem is solved by connecting the batteries, antenna, ground and the speaker to the set. The filament switch is then closed, and the first act is completed—the set works!

Whys and Wherefores

The curtain falls on Act I. We pass out of the foreground and into the lobby—what we actually do is, leave the whole "mess" on the kitchen table and go to the movies—but that thought introduces the apple of short-circuits and hinders the drama in the construction of "Everyman's Receiver—The Fenway."

So we pass into the lobby and listen to the comments on the first part of the show.

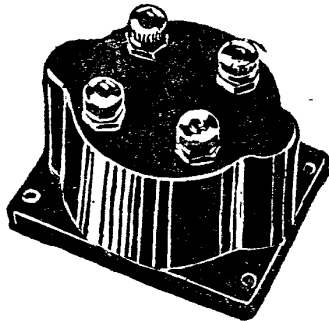

This long-wave transformer is excellently adapted for use in the Fenway.
 Photo, Courtesy Silter-Marshall

"Building the first three tubes," we hear someone saying, "is certainly a novel way of constructing a radio receiver. But it sounds like a sensible way. Instead of mounting all the apparatus for the nine tubes, and then trying to make the whole set work, it seems plausible that building it tube for tube is the better method. And that reminds me," he continues, "that when I built my first set it was a one-tube affair. I operated that set on one tube for over a year, then, when I added two more tubes—an audio amplifier—the whole set functioned beautifully. But later, when I attempted to build a three-tube set for a friend of mine, I ran into lots of trouble, simply because I didn't get the set working on one tube first."

"What I don't understand," another remarked "is why copper cans are used to shield the important circuits."

"That's just the point," said still another. "The important circuits are shielded in order to keep out interference, make the set more selective and improve the quality of reception. And shielding of that nature—where the con-

denser, coil and tube are completely isolated—is coming more and more into general practice. Did you notice that the wires coming out of those cans are at the very bottom, through a hole only large enough to accommodate the wire itself, and possibly a piece of spaghetti that is acting as a protection for the wire? And no attempt was made to pull two or three wires through one hole."

"What I was wondering," said the first speaker, "is what could be done if the thing failed to work?"

How to Check Up

"Well," said someone, "you saw how the set was constructed—tube for tube—then the easiest method of locating any trouble is to go back over the set, beginning with the first tube. If you were to call in a professional trouble shooter—assuming that there is such an animal—he would doubtless locate your trouble through the process of elimination. He would know that only through the systematic elimination of probable defects in the set can the real cause or seat of the trouble be found. Hasty here-and-there quick-search methods generally result in failure. There is always a "certain something" that one can put his finger on, which explains beyond any further speculating why a Fenway will not "percolate"—fails to bring home the bacon.

"Say you find the first condenser has no tuning effect; you turn it this way and that way, but nothing happens. What's wrong? Well, look inside the first copper can. You see there a coil, a condenser and a tube socket—perhaps a tube. Which one of those three or four things isn't functioning? Test the coil for shorts and continuity of circuit; test the condenser for a short circuit; test the tube socket—is it grounded, anywhere, to the can? How about the tube? Are the condenser, coil and socket properly connected into the electrical circuit?

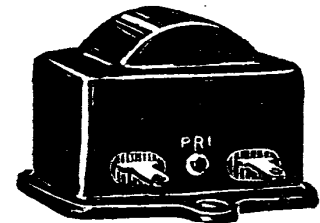

Another type of long-wave transformer that may be used in the Fenway.
 Photo, Courtesy of General Radio Co

nect 45 volts of B to the other; connect the antenna to the fixed plates of the oscillator condenser and the ground to the can. (Of course you must put a grid leak and condenser in series between the grid of the socket and the coil.) Forget the plate winding on the oscillator coil. Just imagine it isn't there. The oscillator now becomes an aerial circuit, and as such should enable you to hear broadcast programs, as before."

(Continued on page 31)

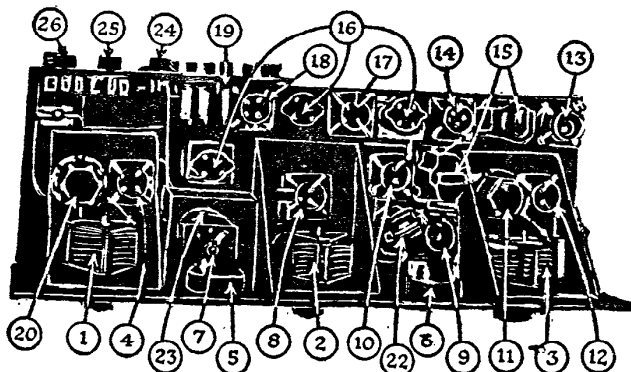

1 and 2 show tuning condensers; 3, oscillator condenser; 4, R.F. socket; 5 and 6, meters; 7, wave-change switch; 8, first detector; 9, second detector; 10, 17, 18, I.F. sockets; 11, oscillator coupler; 12, oscillator socket; 13 and 14, A.F. sockets; 15, A.F. transformers; 16, long-wave transformers; 19, jack switch; 20, antenna inductance; 22, grid leak and condenser; 23, R.F. transformer; 24, potentiometer; 25 and 26, rheostats.

Everyman's Receiver—The Fenway

By LEO FENWAY

This second installment contains directions for the construction of the intermediate-amplifier stages and the second detector of the Fenway Superheterodyne receiver. The first installment appeared on page 28.

ACT II

THE body of the drama, the dramatist tells us, is the story proper. It shows the principal characters doing their stuff, creating interest and suspense and making the playgoer wonder as to the final outcome. Whether one is building a drama or a radio set, once these structural essentials are clearly understood, the builder's progress ceases to be haphazard.

Let us now assume a comfortable posture while we permit the second act to unfold itself before our eyes.

The props—or, if you will, the parts—for these acts are:

- Three Medium-Frequency Transformers, 75- to 15-K.C.
- One Tuned-Stage Transformer, 30-K.C. to 60-K.C. preferred.
- Six Vacuum Tube Sockets.
- Six Standard Vacuum Tubes.
- One Potentiometer, 400-ohm.
- One High Resistance Unit, 1,500- to 100,000-ohm.
- One Filament Single-Control Jack.
- One Double-Pole, Double-Throw Switch.
- One Grid Condenser, .0005-mf. capacity. (Note capacity!)
- One By-Pass Condenser, .005-mf.
- Three By-Pass Condensers, 5-mf.
- One Grid Leak, 5-meg.
- Two Audio-Frequency Transformers.
- One Double-Circuit Jack.

The plot, or circuit, for Act II is indicated by that portion of the hook-up diagram from the "input transformer" to the input of the first grounded core radio transformer. The "business" of examining this diagram is on. The high resistance is shown connected into the circuit of the "B" battery + 67½ volts.

When the set is in operation this resistance will be advanced from one-half to three-quarter-way on, as will be indicated by the reading on the voltmeter—it is shown by the diagram that this resistance is connected to No. 2 on the voltmeter.

The oscillator circuit is now tested. If the oscillator is not working distant stations will be conspicuous by their absence. First of all, are you quite sure that you connected the oscillator coil into the electrical circuit correctly? Well, that's fine; because if you reversed any of the connections the chances are that your trouble lies right there.

The only other possible source of

trouble in the oscillator circuit are: (1) a short-circuited turn in any of the coils; (2) a short circuit or high resistance in the condenser C3; (3) grid and plate connections reversed; or (4) a "dud" tube.

Now place the oscillator tube in the socket, and with the temporary connections still attached to the jack (as explained in Act 1) put on your phones and listen again for a local station.

Tune the two dials, condensers C1 and C2, from 0 to 100. Somewhere on these dials, and at a certain setting of the oscillator dial, the signal will become "muffled." In fact, this oscillating condition will be apparent at both the upper and lower ends of the two tuning condensers, C1 and C2, and should be in effect over the entire tuning range. If the oscillator fails to "mush" the signal over the whole range it indicates that one or both of two things are wrong. Either the range of the oscillator coils

been figuring out how you can save one tube by reflexing the first two or the first and third, forget it. It takes a genuine radio engineer one year to make a second-harmonic-super work, and even then the results are far from satisfactory.

The Middle Section

You should now mount the parts for the intermediate-frequency amplifier. Directly behind the special coupler mount the input transformer. (Whether you use 30 K.C. or 60 K.C. the input must be tuned—not the output. Research work has proven that the proper place for the filter transformer is in the input circuit of the intermediate-frequency amplifier, not the output.)

Next mount the sockets and the intermediate transformers. (The primary side of each transformer should face the sub-panel.) Before mounting the last transformer the potentiometer should be screwed to the panel. If the wires that

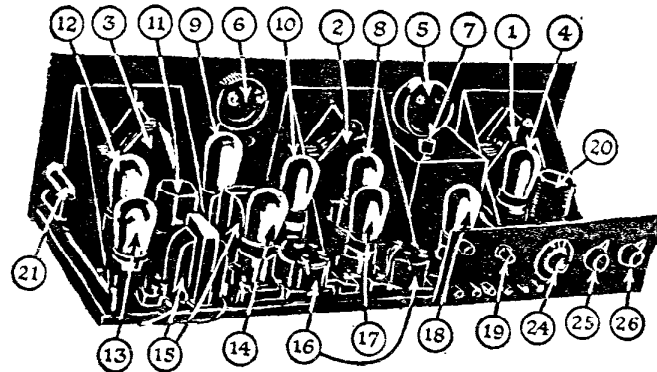

1 and 2 show tuning condensers; 3, oscillator condenser; 4, R.F. tube; 5 and 6, meters; 7, wave-change switch; 8, first detector; 9, second detector; 10, 17, 18, I.F. tubes; 11, oscillator coupler; 12, oscillator tube; 13 and 14, A.F. tubes; 15, A.F. transformers; 16, long-wave transformers; 19, jack switch; 20, antenna inductance; 21, phone jack; 24, potentiometer; 25 and 26, rheostats. Parts shielded by copper cans when in use are seen here.

and condenser does not agree with the other two units (L and C1 and L1 and C2), or the oscillator tube is not working satisfactorily. The remedy is to add or to take away turns of wire (only a few!) from the oscillator coils or put a new tube in the oscillator socket. You must get those first three tubes working before going farther. Otherwise you will likely be trying later on to amplify signals that the first tube does not receive, or that the oscillator does not heterodyne. The average super is a flop right at this early stage of the game. You who build this super can profit from the mistakes of others—get these first three tubes working! The rest of the set will almost take care of itself. If you have

must be attached to this instrument are put in place before mounting it will save time and trouble. After the potentiometer, a 0.5-mf. condenser should be soldered to the last can, either inside or outside; another should be placed in the center can and soldered.

The grid condenser, .0005-mf. capacity, should now be soldered with a short piece of bus to the grid terminals of the last transformer and the second detector tube socket. The filament-control jack comes next. Then, on the sub-panel, the 6-ohm rheostat and the resistance. Once these last two instruments have been set they will not need to be changed—that explains why they have been placed on the sub-panel instead of on the main panel. .005-mf. fixed by-pass condenser should now be mounted from the plate of the second detector to the "A+" battery. Insert the grid leak, which should be 5 megohms. Now mount the double-pole double-throw switch on the sub-panel. The connections for this switch are clearly shown.

Cabling and Connecting

The intermediate-frequency amplifier should now be ready for wiring. It is advisable to use round bus on the grid and plate leads; and these leads should be clear of all other wires and free from spaghetti or other covering. All the filament wires, and all the wires not connected to live grid leads, should be cabled or bunched together and tied very tightly with string. The plate lead that runs from the D.-P. D.-T. switch to the

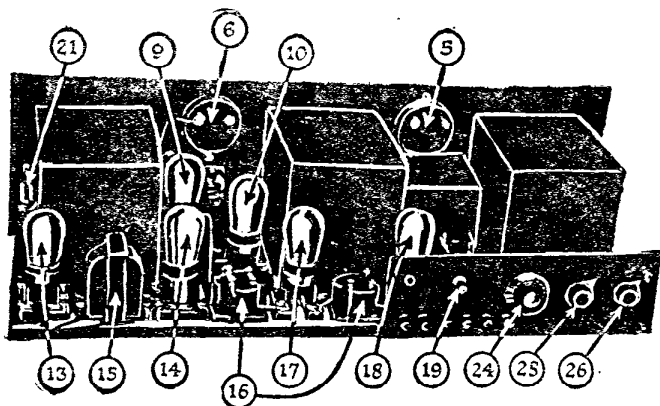

The shielding cans are shown in place. The numbers in this illustration correspond to those in the other on this page.

first audio transformer (for the four tubes), should be included in this cable.

If you "hate" the job of soldering, make an eyelet in the wire with round-nose pliers and trust it to a binding post. Most binding posts are capable of making perfectly good contact, and remember that contact is the thing desired. Mechanical strength and security are needed, of course; but, electrically, it makes no difference whether you use solder or a paperweight to hold two wires together.

For the most part the leads will be very short, with low interaction among the radio circuits.

The intermediate-frequency amplifier and the second detector are usually tested at the same time. If the intermediate-frequency amplifier is wired correctly and the tubes are O.K., there is very little likelihood of trouble, when the proper battery voltages have been applied. If there is trouble of any nature in the amplifier it can be located through the process of elimination.

Beginning with the input transformer, test the primaries and secondaries for continuity of circuit. The voltmeter on the panel can be utilized for this purpose. With the "A—" connected to the minus post on the voltmeter connect another wire to the "A+" through the part to be tested. It is possible, by noting the reading, if any, on the voltmeter, to tell the condition of all transformers. If a 6-volt battery is used the reading will be slightly less than 6 volts.

If there is no reading on the voltmeter either the primary or secondary windings are defective. Fixed condensers can also be tested with the voltmeter, only, of course, there will be no reading when the condenser is O. K. Large by-pass condensers tested in this way will give the voltmeter a slight kick as the condenser charges, but this does not indicate a defective condenser.

Test all the connections on the intermediate-frequency amplifier; see that those between the transformers and sockets are not reversed. The terminals marked "G" on the transformers must be connected to the grids of the tube sockets.) The plate leads can be connected to either of the primary terminals; it is customary to connect a plate to the terminal at the extreme opposite end of primary from grid. Test the intermediate-frequency amplifier together with the rest of the set, as before.

Reaching the Climax

Almost before we realize it the second act is over and we discover that the set not only operates a loud speaker on locals but that distance up to 1,500 miles is clearly brought in. We have a radio set thus far capable of great performance; if we were to walk out before the end of the show we would still have something worth while.

As you still retain your position in the audience, you will readily imagine that the last act will consist of three stages of resistance-coupled audio amplification; the fellow next to you believes that three stages of impedance-coupled will be used; but the man back stage knows that two stages of transformer-coupled audio is the thing. At any rate, you are now convinced that the construction of a super-heterodyne ought to be as simple as that of a three-circuit tuner. In fact it is simpler, only there is more of it. For example, a wire leaves a tube socket (plate) and goes to a transformer (plate), it leaves that same transformer (grid) and goes to a tube socket (grid), and so on to the next transformer and the next tube. Could anything be simpler than that? As often

as not the parts used are O. K., the circuit itself is efficient, but the trouble lies in the man who assembles the instruments. He hasn't learned to visualize his different circuits in scenes. He has entirely forgotten that when he built his first set he wired up one tube—then added more as his radio fever increased. Imagine a dramatist producing his play all in one act! Of course it has been done; and just like the radio that is constructed in one lump, it has lived for but a day, then flopped.

ACT III

And so we come to what the dramatist calls "The end of the play." And, being the last act, it is necessarily the shortest. As the final curtain rises we see the same props—or parts—that were used in creating the first setting, with the added parts of the second part. By tossing upon the stage—or baseboard—a couple of good low-ratio audio transformers, two sockets, two tubes, either power tubes or otherwise, the action for the close of the show is begun.

The instruments mentioned are connected into the circuit, as indicated in the right end of the diagram. Once again the batteries, the aerial and ground—or a loop—are connected, the speaker plugged in and—there you are!

What's that you say? There is no climax to my drama! Oh, yes, there is! It comes after you readers have constructed my set. It comes right in their own home, where all good climaxes should come. When the readers of RADIO NEWS discover that this set will function on either four tubes or nine, when they learn that it will cover wave-bands of from 50 to 600 meters, when they know that the quality of reception leaves not the slightest indication of the mechanical—when they hear 3,000-mile stations with the volume of locals—and "maybe" doesn't enter into the scheme of things—when all these events come to pass, that's the climax.

Everyman's Receiver The Fenway

(Continued on page 29)

"What I like about the first act of this drama," you can't help thinking, "is that, although the laboratory model must use certain makes of parts, the use of these parts is not entirely essential to the success of the set. The antenna and oscil-

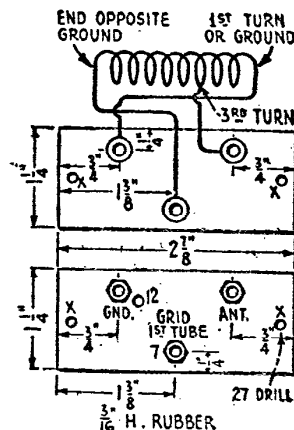

The working drawing for the construction of the antenna coil and its holder and sockets. This is coil L in the diagram on page 1656.

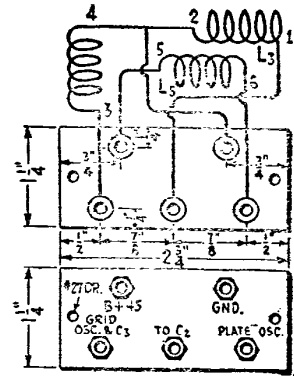

This sketch illustrates the mounting of the oscillator coil, L3, L4 and L5 in the diagram on page 1656.

LIST OF PARTS FOR FOUNDATION UNIT

- 1 Antenna coil (for waves from 35 to 550 meters) L. L.
- 1 R.F. coupler (details page 1657)
- 1 Oscillator coupler (L3-L4-L5)
- 2 Mounting bases for couplers
- 3 Variable condensers, S.-L.-W., .00035-mf (C1, C2, C3)
- 1 Panel, 8x28x3/16 inches
- 1 Rheostat, 6-ohm
- 3 Vacuum tubes, 201A type, and sockets
- 3 Vernier dials
- 1 Filament switch
- 1 D. C. Jack
- 1 Grid condenser, .00025mf., and grid leak, 1-megohm
- 1 Fixed condenser, 0.5-mf.
- 1 Sub-panel, 4x12 inches
- 1 Piece insulating material, 2 1/2 x 2 1/2 x 3/16 inches
- 1 Tap switch and 3 taps
- 1 Safety fuse and mounting
- 1 Milliammeter, 0-50
- 1 Voltmeter, 0-8-80-160 (special type)
- 8 Binding posts (A, G, -A, +A, -B, +B Det., two + B Amp.)
- 1 Baseboard, 9 1/2 x 27 1/2 x 1/2 inches
- 4 Copper cans (3 are 5x6x1/2; 1 is 4x4x4)
- 50 feet No. 14 or 15 rubber-covered flexible wire
- 3/4 pound No. 32 copper wire, D.S.C. or D.C.C.

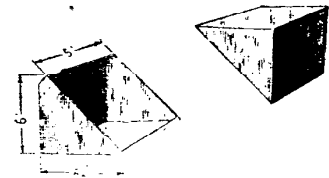

This diagram shows the type (can) and size of the copper shields used to isolate the different parts of the Fenway superheterodyne.

lator coils can be constructed at home, and all types of condensers of consistently high quality may be expected to approximate the results obtained by the laboratory model. So, as I consider this statement" you hear yourself saying, "I should commence work at once. Like most every radio enthusiast, I have enough spare parts on hand to form a foundation for the Fenway. I guess I'll build it now and own the outstanding—but, there goes the curtain on the second act!"

Second-Harmonic Superheterodyne

A Simple and Helpful Explanation of the Principles Underlying this Non-Interfering Circuit

By L. R. FELDER

SUPERHETERODYNE sets working on the "second harmonic" have been the cause of wonder as to what is the underlying mystery. The second harmonic Superheterodyne works on the same broad principle as all other Superheterodyne sets; the incoming low wave (high frequency) signal is transformed into a high wave (lower frequency) signal, which is then more easily amplified by efficient high wave amplifiers.

The method by which the frequency is changed from low wave to high wave, or from high frequency to low frequency, involves the use of a radio-frequency oscillator and the principle of beats. In Fig. 1 we have a typical loop circuit tuned to an incoming signal of high frequency, let us say 950,000 cycles, which corresponds to a wave-length slightly higher than 300 meters. There is also shown a radio-frequency oscillator which is tuned to a frequency of 1,000,000 cycles let us say, and these oscillations are coupled

a frequency of 950,000 cycles, while the locally-generated oscillations have frequency of 1,000,000 cycles, only 50,000 cycles apart. Some receivers are built so that the difference in frequency is even less, say about 30,000 cycles. It will be seen that this difference in frequency is perilously near the audio-frequency range and this introduces an audible sound from the receiver.

Interference due to receiver radiation is caused by so much regeneration that the receiver acts as an oscillator and radiates these generated oscillations. Nearby receivers working on approximately the same wave-length pick up these oscillations and beats are set up between the incoming signal and the oscillations due to the regenerating receiver. The squeals and other interfering noises are the beats set up between two oscillations.

In the Superheterodyne circuit we have a somewhat more aggravated case of

because frequencies would be so far apart that the beat note was well outside the audio-frequency range. This could be done by making use of the second harmonic of the generated oscillations.

A vacuum tube oscillator does not ordinarily generate a single frequency for a given setting of the circuit constants. Thus suppose that the constants are so fixed that the oscillating circuit tunes to 600 meters, 500,000 cycles per second. Then the vacuum tube oscillator will generate radio-frequency oscillations of this frequency, but at the same time it will generate oscillations of double this frequency; namely, 1,000,000 cycles; three times this frequency, 1,500,000 cycles, and so on. The lowest frequency which it generates is that to which the oscillating circuit is tuned, in this case 500,000 cycles, and this frequency is called the fundamental or first harmonic. The oscillation of double the fundamental frequency which it generates is the second harmonic. Inasmuch as the oscillating circuit is tuned to the fundamental it is to be expected that most of the energy of the oscillator is in this frequency. The succeeding harmonics generally have less energy in them. Thus a radio-frequency vacuum tube oscillator generates oscillations of various frequencies which bear a certain ratio to the fundamental frequency, and what is most important to this discussion, the second harmonic oscillation generated by such an oscillator has a frequency of twice the fundamental.

Consequently it is possible to make the Superheterodyne oscillator tune to a frequency far removed from the range of frequencies being received, and still secure our intermediate beat frequency of 30,000 to 50,000 cycles, and this without creating any interference. Let us consider the numerical illustration above. Suppose that we are receiving a broadcast signal of frequency of 950,000 cycles, which corresponds to a wave-length somewhat greater than 300 meters. And let us assume that we desire to transform this high frequency down to an intermediate frequency of 50,000 cycles. If we design the oscillator so that it tunes to a frequency of 500,000 cycles, corresponding to a wave-length of 600 meters, the oscillations will be sufficiently far removed from the broadcast range to avoid any interference due to direct radiation of these oscillations from the loop antenna or other antenna. However, 500,000 cycles cannot combine with the received 950,000-cycle signal to give us an intermediate beat frequency of 50,000 cycles which may be efficiently amplified. However, this is the fundamental frequency of the oscillations generated by the oscillator. The second harmonic of the oscillator has a frequency of two times the fundamental, or 1,000,000 cycles. The 1,000,000 cycles second harmonic can beat with the received signal of 950,000 cycles and form the required 50,000-cycle beat frequency. And this is exactly what the second-harmonic Superheterodyne accomplishes.

It should be observed that the fundamental of the oscillator also beats with the received 950,000-cycle signal. How-

(Continued on page 34)

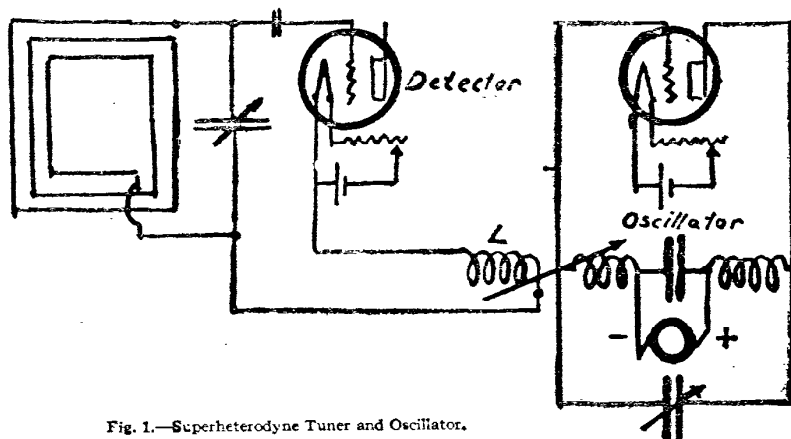

Fig. 1.—Superheterodyne Tuner and Oscillator.

to the loop circuit by means of the coupling coil L. The incoming signal oscillations and the locally-generated oscillations are therefore present in the same circuit and applied to the grid of the detector tube.

These two oscillations, according to the fundamental principle of beats, combine to form another oscillation having a frequency which is equal to the difference. Thus we have a resultant oscillation having a frequency equal to 1,000,000 minus 950,000, or 50,000 cycles. In place of a signal having a frequency of 950,000 cycles (which is very difficult to amplify due to impossibility of building a good low wave amplifier) we have a signal having a frequency of 50,000 cycles which is a simple matter to amplify efficiently. The frequency transformation does not itself involve any change in the characteristics of the original signal. That is, the resultant 50,000-cycle signal has all the characteristics of the original 950,000-cycle signal which it is desired to hear.

It is thus apparent that the radio-frequency oscillations generated by the local oscillator must have approximately the same frequency as the received signal. In the above case the received signal has

the same type. In place of the oscillating regenerative receiver we have a radio-frequency oscillator which is a miniature transmitter whose oscillations are radiated by the loop circuit.

The usual types of Superheterodynes oscillate at about the same frequency as the receiver signal. If anyone in the immediate vicinity of a Superheterodyne set is receiving signals of nearly the same frequency as the oscillator in the Superheterodyne sets generates, and the loop radiates these oscillations, the possibility of audible beats with consequent interference being developed is considerably enhanced. There is no doubt that such interference does take place. However, the Superheterodyne set is not sufficiently widely distributed for it to be noticed, and many supers use a radio-frequency blocking tube which helps cut down the interference.

To avoid possibility of such interference, the second harmonic principle was invoked. If a set could be made in which the radio-frequency oscillator generated frequencies far removed from the frequencies of incoming signals, then, even though the oscillations were radiated from the loop, no audible interference would be produced in other receivers

A Neatly Designed Superheterodyne

Care in the Design of this Set Is Not Overlooked

WE have presented in the foregoing pages of this book a representative selection of various types of Superheterodyne, all of which have proven very efficient. However, we do not assume the claim of any as being the "last word in radio receivers." What we like about this one is that it does not make any unreasonable claims for its distance-getting properties, and it does lay stress on neatness and compactness; but, best of all, the self-explanatory pictures given herewith, make this set easy to build by following the same layout with standard parts.

The description of the compact Superheterodyne shown in the accompanying pictures appeared in a recent issue of RADIO NEWS, New York, and is given below.

There is a widespread idea that a standard Superheterodyne, because it has eight tubes instead of five, is about eight-fifths as good a set as a standard five-tube receiver. Without attempting to say whether this is or is not a fair estimate of the general superiority of the super, it should be pointed out that there are quite important differences of a fundamental nature between the usual five- and eight-tube receivers which make it unfair to both types to judge by the number of tubes alone.

The Superheterodyne has no need of more than two main tuning controls, and at least one of these can be made practically as sharp as the builder desires to make it. The degree of selectivity secured in a properly designed Superheterodyne is a compromise between the desirability of extremely sharp tuning and the necessity of preserving tone quality.

Quality vs. Selectivity

A set which will separate stations a fraction of a meter apart may be an interesting plaything, but a set which will put into the

loud speaker actual musical tones from distant stations 2 or 3 meters apart is a much more useful piece of property. The set here described has sufficient selectivity, when operated at Chicago, to tune through the 16 local stations and pick up Los Angeles and other Pacific Coast stations whenever their signals are distinguishable from static in Chicago. With this degree of selectivity, there is preserved a quality of tone which differentiates the set at once from the "tuning-stunt" Superheterodyne. With the addition of laboratory-grade audio transfor-

mations to carry this same completeness of overtones into the loud speaker, we have a set which leaves little, indeed, to be desired in a musical way.

The set is built on a panel 7x18 inches and a sub-panel 7x17 inches. It can thus be slipped into any standard 18-inch cabinet,

tubes through reflexing and combining of oscillator and first detector. These are complications which have been properly avoided.

Assembling the Set

The sub-panel construction, employing the

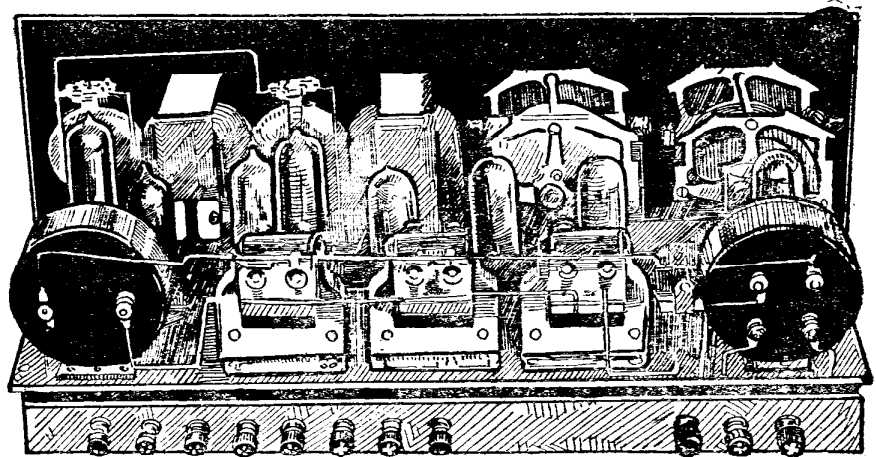

Rear view of the Superheterodyne receiver showing how, by this arrangement of apparatus, it is possible to build the set on a 7 x 18-inch panel.

and is also splendidly adapted for use as a portable set.

No attempt will be made here to outline the general theory of Superheterodyne operation. The circuit of the present set is practically standard. Some will object that it is not possible to get the last degree of amplifying power out of a super without potentiometers, numerous rheostats, adjustments of oscillator coupling and other com-

plexities, but this is not the case. The binding posts of the tube sockets very largely to carry connections from one side of the sub-panel to the other, enables the set to have a clean-cut appearance from above, which is almost never attained in supers.

Before any of the tube sockets are mounted they should be carefully prepared by reversing the necessary screws, as shown, in each socket; two or three are reversed in each case, and these serve to attach the sockets to the sub-panel, as well as to carry electrical connections through the sub-panel.

All of the reversed screws must be finally tightened, with nuts holding the contact springs, before being mounted on the sub-panel; then, before the nut is attached on the bottom of the sub-panel the lug should be attached there also, and turned in the proper direction. Lugs are to be bent up.

First, the set can be wired quickly and neatly without using "spaghetti" tubing, except in two or three places where specified.

Second, wires need never run over the ends of screws so as to prevent access with a socket wrench.

If wiring directions are followed exactly, it will be found possible to remove and disconnect any instrument in the entire set without disturbing any other—a feature which is too frequently lost sight of in the building of elaborate radio sets.

A difficulty which may be encountered with these inverted socket screws is that in giving the lower nut at the lower end a final tightening after soldering, the nut between socket base and sub-panel may come loose, and it is inaccessible to hold while tightening the screw. In this case, simply loosen the bottom nut and press it (or the screw) tightly upward; this pressure will hold the inaccessible nut still for tightening.

When the set is completed, it is best to try connecting the "A" battery to the "B" battery terminals of the set to make sure

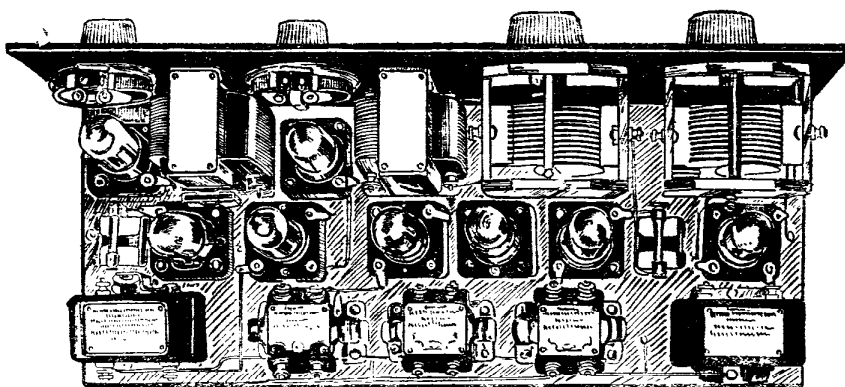

Top view of the Superheterodyne receiver which is remarkable for its compactness.

plexities. These claims may be admitted at once: it is generally found that when all such aids are utilized to best advantage even a seven-tube super will receive any signal down to the noise level. In the present design it has been considered better to get an added margin of sensitiveness by using the additional tube (which introduces no extra operations in using the set) rather than to adopt these extra sub-controls and assume that they will be used to their full effectiveness. Much the same applies to the possibilities of saving in the number of

loud speaker actual musical tones from distant stations 2 or 3 meters apart is a much more useful piece of property. The set here described has sufficient selectivity, when operated at Chicago, to tune through the 16 local stations and pick up Los Angeles and other Pacific Coast stations whenever their signals are distinguishable from static in Chicago. With this degree of selectivity, there is preserved a quality of tone which differentiates the set at once from the "tuning-stunt" Superheterodyne. With the addition of laboratory-grade audio transfor-

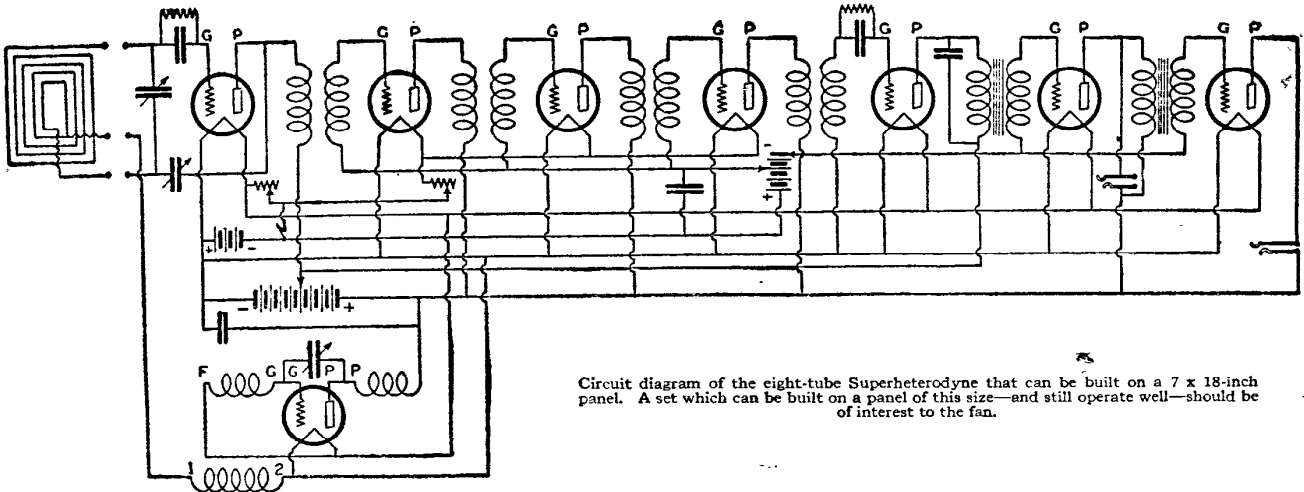

Circuit diagram of the eight-tube Superheterodyne that can be built on a 7 x 18-inch panel. A set which can be built on a panel of this size—and still operate well—should be of interest to the fan.

that the tubes do not light. If they do, it of course indicates the presence of a wiring error, which would blow the tubes if the "B" battery was connected. If this test shows no trouble, the batteries may be connected for regular operation.

The three "loop" binding posts are to be connected to any standard tapped loop, the center post going to the tap. Loops are commonly tapped at the center of the winding. It may be found with this super that slightly better results are obtained by tapping a little off center. The feed-back provided by this tapped loop is controlled through the .000045 variable condenser. Increasing this capacity up toward the point of oscillation will be found to sharpen the tuning and probably increase the voltage of signals.

The small variable condenser is for controlling the loop regeneration, and in operation it is simply left "out" entirely until the set is working satisfactorily on reasonably strong signals. Throwing this small con-

denser part way in then introduces a feedback which sharpens the tuning and materially increases the sensitiveness of the set for use in long-distance reception. It should,

of course, never be turned on enough to cause oscillation of the first detector tube.—which is indicated, when it occurs, by a click and mushy signals.

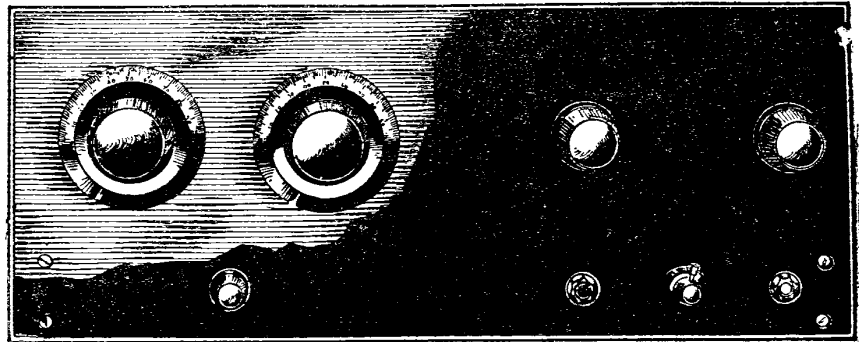

Panel view showing the small condenser knob below the two large dials.

A 3000-Mile Superheterodyne

(Continued from page 10)

tapped at the center and the rotor (for regeneration) of 30 turns of No. 26 D.S.C. If it is desired to use a small indoor aerial, a coil should be made up as follows:

Obtain a tube 3½ inches long and 3 inches in diameter and wind on it 36 turns of No. 20 D.S.C. wire. Over the center of this winding wind 8 turns of No. 16 D.S.C. wire. This is used for the aperiodic aerial coil.

The loop aerial consists of 12 turns of flexible wire, tapped every three turns.

The operation of this set is simple. After having plugged in a suitable radio frequency transformer before the detector, the tickler coil is at zero and a local station tuned in. This should be received without the aerial. (In fact, I have received a station a distance of 550 miles away without aerial, the signals being audible on the loud speaker.) The transformers are so tuned that the loudest signals are received. Now tune in a distant station and retune the transformers, which are very sharp in tuning. It will be noticed that there is a distortion due to the fact that the side bands are cut off. The iron cores are now inserted through the holes in the box. These cores consist of three pieces of silicon steel 2 inches long, ¼ inch wide and .003 of an inch thick. These cores are inserted until all the distortion has disappeared. The iron core is not inserted into the input or filter transformer. Once the transformers have

been tuned to the maximum signal strength, they need not be touched again. Now the regeneration coil is rotated until the maximum strength is obtained.

To change from one wave-length to another it is only necessary to insert a radio frequency transformer of a suitable wave-length into the tube socket before the detector.

It is also well to mention that tubes taking .06 of an ampere at three volts are used throughout this receiver.

You will find this set very stable, easy to handle, very sensitive and selective on weak and distant stations, and any reader who constructs this set will feel himself well repaid for the time and labor spent. He ought, under reasonable conditions, to be able to receive European stations.

Second-Harmonic Superheterodyne

(Continued from page 32)

ever, the beat frequency is so high that it is inaudible and so creates no interference. The whole idea is to make the oscillator so that, if it does radiate oscillations, their frequency is so far removed from received frequencies that no audible interference is created. At the same time provision must be made for enabling the intermediate beat frequency to be secured, and this is made possible by the presence of harmonics in the generated oscillations.

It is possible with a Superheterodyne to find two positions of the oscillator setting at which any given station may be received, because the oscillator may

be set 50,000 cycles above or below the received signal frequency and still a 50,000-cycle frequency will be obtained. Thus, suppose a 950,000-cycle signal is being received. If the oscillator is tuned to 1,000,000 cycles a beat frequency of 50,000 cycles will be secured, since it is the difference of 1,000,000 and 950,000. Also the same result will be secured if the oscillator is tuned to 900,000 cycles. It often happens that a station is heard at more than two settings of the oscillator dial, sometimes three, four or even more. The reason is that transmitting stations likewise may be radiating, not a pure wave, but one with harmonics. As a result, when the oscillator of the Superheterodyne is tuned over its range a number of settings may be found where the same station is picked up, for at each setting of the oscillator control a beat is produced between the new oscillator frequency and a harmonic frequency of the transmitting station. The writer has heard a given station on as many as six different points of the oscillator scale. This is not usual, but occurs with transmitters which radiate a very impure wave.

To work on the second harmonic principle the oscillator must be designed to oscillate at twice the wave-length of the received signal over the entire wave-length range of the tuner. Thus suppose that the receiver is intended to cover a wave-length range from 300 meters to 500 meters. The oscillator should then be designed to cover the range from about 600 meters to 1000 meters, the second harmonics of which will then cover the same range of frequencies and wave-lengths as is covered by the tuner itself. The circuit arrangements and connections are exactly the same as for the more standard type of Superheterodyne circuit.

The Most Novel Superheterodyne

By D. C. WILKERSON

Mr. Wilkerson presents an almost revolutionary principle in the Superheterodyne scheme detailed in the article below. Every experimenter, as well as layman, will be extremely interested in the possibilities it admits.

It is the ambition of every scientist and experimenter to produce the *ultra* in his line of work. That is natural, and it is the thing that makes experimentation and study in scientific work so fascinating.

Ever since Major Armstrong announced his Superheterodyne circuit, there has been a strong and continuous interest in it, and many novel variations of it have appeared before the public in these and other columns. One very notable variation of the principle is the circuit devised by R. E. Lacault, former associate editor of RADIO NEWS—the Ultra-dyne.

There have been others. Many different styles of oscillators and detectors, and varied types of radio frequency transformer cascades have been tried out. Some have been built for antennae and others have been made solely for loop aerial work.

The Standard Type

The customary style of Superheterodyne common among those who build their own, has eight tubes in straight amplification work. There is a first de-

In publishing Mr. Wilkerson's article, we must make it plain that this is as yet a theoretical circuit. Although Mr. Wilkerson has done quite a good deal of experimental work on the circuit, much remains to be done. Another article, giving more data on results, will be published in a forthcoming issue of RADIO NEWS, this article also being written by Mr. Wilkerson. We are publishing the article chiefly on account of its novelty. It embodies some good ideas and the readers are given much food for thought, particularly those readers who care to leave the beaten path. We are all apt to follow along somewhat the same lines, and it is most refreshing to stray afield once in a while.

detector and oscillator, a three-tube cascade of radio frequency, a second detector and two audio frequency amplifiers. This requires first of all a large panel and a long one, and a considerable amount of accessory instruments.

Coming into vogue today is the application of the reflex principle, and we are discovering that many ingenious designers are getting double work out of their tubes by clever handling of reflex ideas. The application of reflex to the Superheterodyne, however, is simply carrying out the old adage, "Every little bit added to what you've got," and the true meaning of reflex-plus-super is only to reduce the number of tubes required to run the set.

There are so many and varied adjuncts to the art of radio that one is always at a loss to know what principles or instruments to use when a certain result is desired.

This writer is one of the many who decry the "bloopers" and believe that legislation should be enforced to drive the radiating set out of existence for good and all. Carrying out these ideals practically, the writer must perforce own and operate a radio set which will not annoy the neighbors, and which will not radiate disturbing impulses of a radio character.

Like many others, also, this writer desires to own a most efficient radio set, one which will reach out to the nethermost parts of the world and drag in the distant stations. One, under these conditions, naturally turns to the Superheterodyne.

This writer is one of those, also, who desires to build his own set instead of getting a "boughten" receiver.

Summing up the requirements for a Superheterodyne which shall not radiate, which shall not be factory made and which shall incorporate something new in the way of contribution to the art, we are confronted with these things:

1. We will not fool with the reflex. Practically everyone else has, and we would not, therefore be traversing virgin ground.
2. We must consider deeply some way to avoid oscillation in the first detector. Here is where radiation can start.
3. We must prevent spilling over from the oscillator circuit which heterodynes into the master circuit.
4. We must stop all oscillating tendencies arising from faulty radio frequency construction, feed-back from second detector circuits and throw-overs from the audio end.

Crystal Detector

The first consideration then is to eliminate oscillation from the first detector. A bold stroke here would be to substitute for the customary tube at this point, a crystal, or else some other detector which would not and could not oscillate.

Right here and now, this writer is going to "start something." He is going to try out the much despised and little used electrolytic detector. Don't laugh at this. Just remember that the first real and reliable distance transmission and reception records in wireless were due to the success of this type of detector.

This writer remembers, many years ago, in 1910 and 1911, when the present editor of the RADIO NEWS magazine, Mr. Hugo Gernsback, was piloting his first radio publication, MODERN ELECTRICS, and how the introduction on the market of the old E. I. electrolytic detector made great distance records for the amateurs. This device had a small Wollaston wire (a very small diameter platinum wire) with adjusting means, to dip into a carbon cup filled with weak muriatic acid solution.

Electrolytic Detector

The wide prevalence of lead-sulphite ore, the purer parts of which could be used

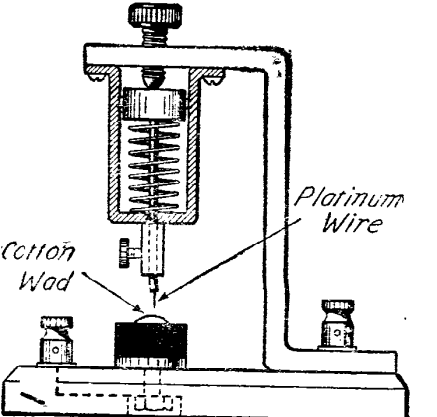

The most efficient form of electrolytic detector, using cotton soaked in electrolyte.

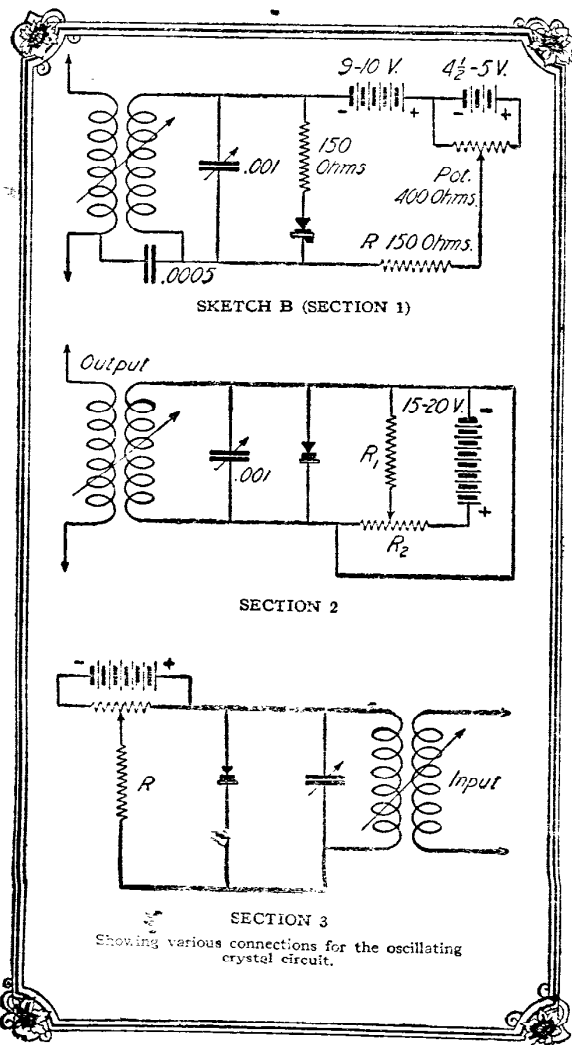

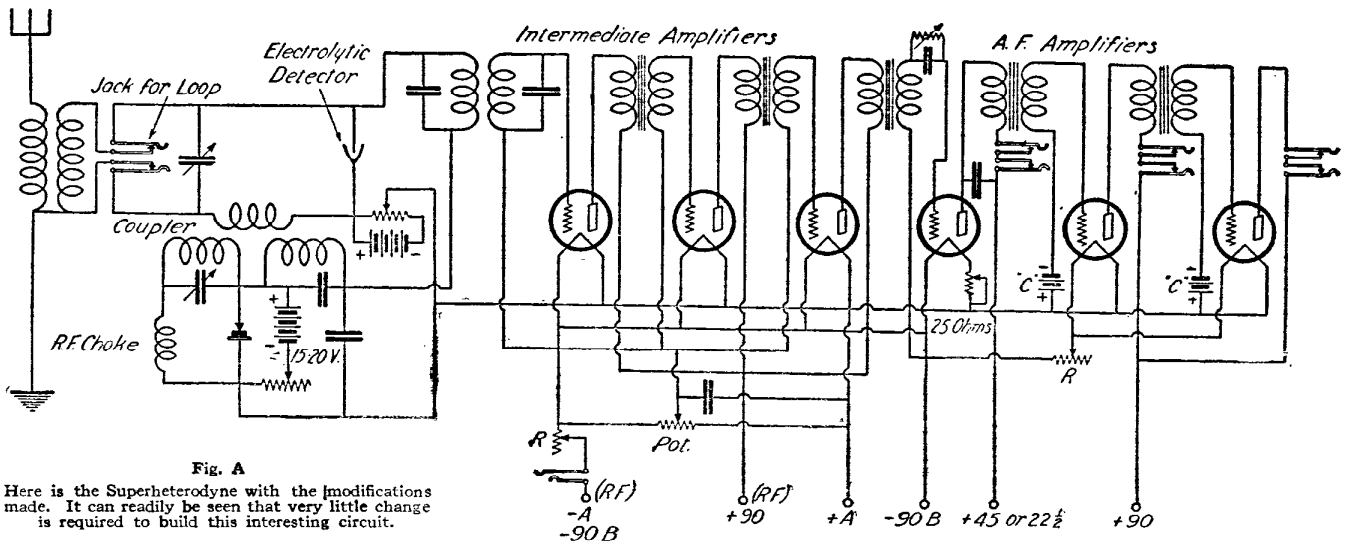

Fig. A

Here is the Superheterodyne with the modifications made. It can readily be seen that very little change is required to build this interesting circuit.

as detector crystals (galena) drove the unsteady electrolytic detector to an early and unjustified grave. This writer believes that the radio art would have been much farther advanced in the progress of the study of ion and electron movements if the electrolytic detector had been kept alive in the art at the time of its popularity.

Another reason for the early demise of the electrolytic detector was that it had to have a steady table, undisturbed by jolts, swings or jars, such as encountered at sea, to perform its best. Upon what tiny things does the fate of ideas rest! If these early electrolytic pioneers had only done what this writer had done, put a small ball of absorbent cotton soaked in the electrolyte in the carbon cup. No matter how much the ship rolled, we always had contact, and the old Wollaston wire brought in the message. The tiny fibres of cotton clung to the platinum wire and seemed to improve the character of reception.

Then, we are going to try out electrolytic means in a first detector. So far so good. How about the oscillator?

Surely we will have to eliminate for good and all any chance of undesirable oscillation from this source so we will also dispense with the oscillator tube. There's nothing like being original, anyway. What can we get to do oscillation work with? How about one of those fixed crystal quartz oscillators? This would give us a nice continuous frequency without variations. How would we vary this frequency, though? We'd have to devise some means of tuning which would bring the resultant oscillations within the super-audible frequency peak of the intermediate stages of radio frequency amplification.

A quartz crystal is not the only means by which we may obtain oscillations to heterodyne the incoming signal down to the proper frequency range.

There are many kinds of odd oscillating mediums, but few are adaptable to the reception of modulated signals. Let's look around. How about another relic of radio's forgotten graveyard? How about trying out the old piece of zincite and a steel needle contact? Lossev, the celebrated Russian scientist, has accomplished some remarkable results with different crystals, having produced amplification and many other radio phenomena, as told in the pages of RADIO NEWS from time to time.

We will not try to devise any further means for detecting and oscillating at this point. Just now we have enough new material to work with.

Heterodyne Theory

Let's review our theory a bit. The ordinary Superheterodyne works on the principle that the incoming signal is used to create a flux field in a circuit, which generates a current of feeble intensity in that circuit. This current is placed in phase or in resonance with a connected circuit, where it is led to a vacuum tube grid, the impulses being there detected, heterodyned through a separate coupled oscillator circuit and then fed into a cascade of super-audible frequency stages and amplified. The output end of this latter amplifier bank is led to the input side of a second detector where the impulses are chopped down again, but this time to audible frequency, to pass on through into audio frequency stages to the final output—phones and loud speaker.

Our immediate problem is to substitute for the first detector the electrolytic detector. How this is done is shown in Fig. A. So far so good.

Thus far no complications have arisen. Now we are confronted with the problem of substituting an oscillating medium for the first and only oscillating tube. The general scarcity of oscillating quartz crystals, and the rather easy access to zincite crystal supplies in most parts of the United States, leads us to try out this latter means in order to lay down a plan that most any radio experimenter can follow.

The zincite-steel combination is known as the *Crystodyne* detector, and it has been afforded considerable space and discussion in the columns of RADIO NEWS under the names of the editor and I. Podliasky, E. F. On page 294 of the September issue and on page 470, October issue, 1924, a clear understanding of the *Crystodyne* idea is given. It can be used for straight detection, for spark and arc detection, for regenerative action, for oscillation and for audio frequency amplification, as well as radio frequency amplification.

We are more interested here in the means for obtaining oscillation, and the impressing of it on the detector circuit, so that the incoming signals may be heterodyned into the intermediate radio frequency amplifier. The customary coupler is used, inductively connecting the oscillator into the detector circuit.

Fig. A shows a trial hook-up of the Superheterodyne equipped with a first detector of the electrolytic class, and an oscillator of the *Crystodyne* type. This hook-up will not be the ultimate one, as there has not been time before this publication goes to press to work out the different association values and the circuit constants best fitted to provide oscillation.

Several different methods of producing oscillations and the way to impress them on the electrolytic detector circuit are shown in Fig. B. Naturally, the coupler and tuning condenser values will depend upon the frequency at which it is desired to operate the radio frequency stages. The writer is equipped with 43,000- and 35,000-cycle R.F. transformers, and the variable condenser value of the tuner of .001 mfd. is the one to be used under these conditions.

Section 2 of Fig. B shows a variation allowing finer adjustment of the battery voltages across the crystal, which will be found to be very critical at best.

Adjustments

It has been found, thus far, that a sharp click will be noted if head-phones (Continued on page 41)

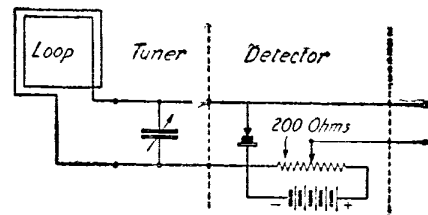

A loop antenna gives excellent results with this super.

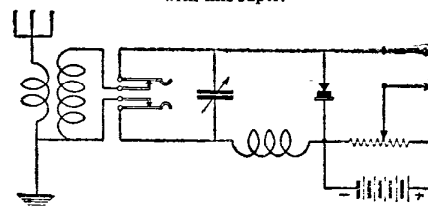

An inductively coupled antenna can be used with the zincite oscillator.

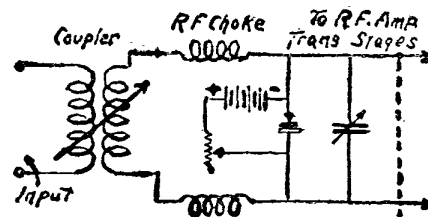

Another method of using the crystal oscillator as an autodyne, dispensing with a separate oscillator. The variable condenser readily governs the frequency.

Matching Intermediate-Wave Transformers for Superheterodynes

By PROFESSOR GROVER IRA MITCHELL

If maximum radio frequency amplification is to be obtained in a Superheterodyne receiver, it is necessary that each intermediate-wave transformer be tuned to the same frequency. Professor Mitchell has described in this article an excellent method of matching these transformers.

THE attention which the Superheterodyne circuit is receiving at this time has awakened a keen interest in the design of the intermediate-wave transformers used in its amplifying stages. These transformers are now made in two types, the first of which is able to respond to wide range in frequencies, ranging from 5,000 to 25,000 meters; and the second, to respond to but a very narrow band of frequencies, usually in the neighborhood of 10,000 meters.

The amplifying curves of the two types are shown in Fig. 1. A comparison of the curves shows that the broadly tuned transformer has a relatively low amplification factor, while the sharply peaked transformer has a very high amplification factor for the frequency to which it is able to respond. It is at once realized that the maximum amplification of the heterodyned signal wave will be obtained only when the transformers in the intermediate stages are of the sharply peaked type with the peaks of all the transformers occurring at the same frequency. In order to be sure of this condition, the builder of a Superheterodyne receiver must make certain that the transformers he is using do peak at the same frequency. The exact frequency at which the peak occurs is of no particular importance, so long as it is in the neighborhood of 10,000 meters—a frequency which most authorities have accepted.

The sharply peaked transformers have an air core, since the presence of an iron core tends to broaden tuning. Several sets of specifications for building such air-core transformers have appeared in RADIO NEWS, and the radio experimenter will have no difficulty in building and winding his own. After such transformers have been constructed, it is necessary to match them so they will respond to the same wave-length if the maximum amplification is to be secured. The author has found that in winding these units, even when the same sized forms are used

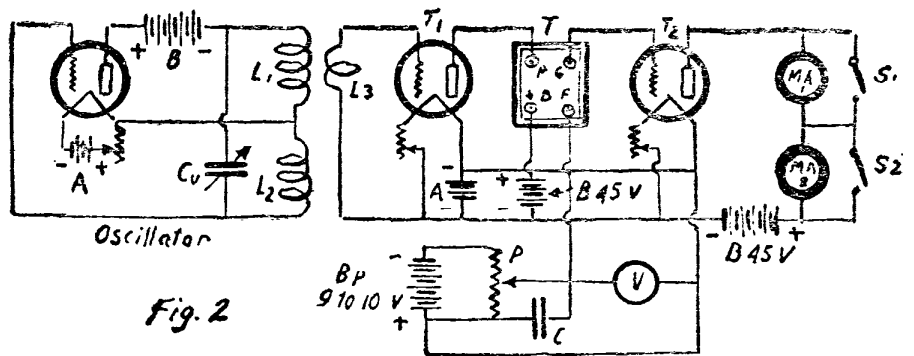

The transformer matching circuit is shown above. Coil L₂ may be shunted by a sensitive ammeter in order to check the amplitude of the oscillator so that it may be kept the same throughout a test.

Test Method

The author has used the method and apparatus, which will be described, to ascertain the point at which each of the several transformers peak and to select transformers for each set to be built which peak at the same point.

The first requirement is a vacuum-tube oscillator generator, the circuit of which is shown at the right of Fig. 2. This circuit must be capable of generating oscillations of a wave-length varying between 5,000 and 15,000 meters, or from 20,000 to 60,000 cycles per second. The author has found that if coils L₁ and L₂

The remainder of the circuit of Fig. 2 is a straight amplifier circuit, modified to suit the requirements of this particular type of work. The coil L₃ has but one turn. This coil is very loosely coupled to coils L₁ and L₂, the coupling being variable to permit adjustment of the amount of energy it picks up.

The transformer to be tested is inserted in the circuit as shown at T, its +B terminal being connected to 45-volt block of "B" battery and its F terminal is connected to the center terminal of a 400-ohm potentiometer P, placed across the Bp battery as shown. This battery should consist of about six standard dry cells. This battery is connected to the positive terminal of the "A" battery supplying the filaments of the amplifying tubes. The voltmeter V is connected between the center terminal of the potentiometer and the positive "A" battery terminal, as shown. The fixed condenser C should be of about .0005 mfd. capacity and is inserted as shown to serve as a by-pass to the potentiometer winding for the radio frequency.

The plate circuit of the tube to the right of Fig. 2 contains two milliammeters, MA1 and MA2, each of which can be short circuited by a switch. MA1

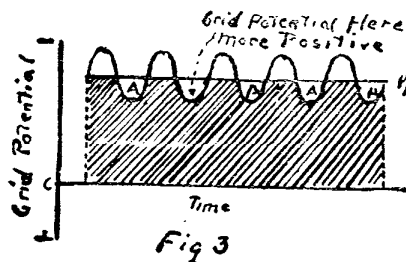

The effect of the oscillations produced by T₁ on the grid potential of tube T₁.

are of 500 turns each, of the honeycomb type, the two coils being mounted side by side with their axes coinciding, taking care that their magnetic fields are "boosting" and not opposing each other, and having the condenser C_v of the 43-plate type, the oscillating frequency of this circuit will be capable of variation within the mentioned limits.

The variable condenser C_v should have its settings carefully calibrated for the frequencies ranging from 8,000 to 12,000 meters, this being the range most apt to be used. The other frequencies between the lower and maximum limits may also be calibrated, but this is not so important. The calibration may be done by any one of the many methods described in past issues of RADIO NEWS, or the oscillator may be sent to the Bureau of Standards, or to the laboratories or many of our state colleges or universities, to be calibrated.

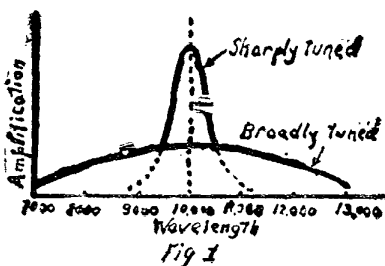

Amplification curves for a broadly tuned transformer and for a sharply tuned transformer.

and the same number of turns employed in each transformer, unless the turns have been very carefully wound into flat layers with the same number of turns in each layer—a very painful and laborious job—the inductance of the windings will vary sufficiently between the different transformers to make their peaks occur at widely different frequencies.

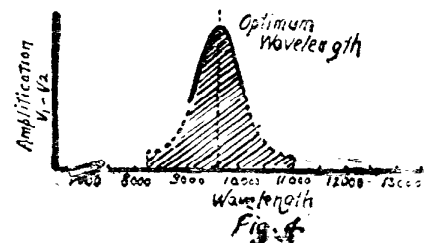

An amplification curve of a transformer which amplifies at maximum just below 10,000 meters.

should be capable of reading the maximum plate current, about 15 milliamperes, and MA2 should be a very low reading instrument capable of giving a large deflection for currents as low as 0.1 milliamperes.

The use of this apparatus for measuring the amplification of the transformers under test is as follows:

(Continued on page 41)

The Tropadyne Circuit

By CLYDE J. FITCH

There are constant improvements being made in the Superheterodyne receiver. The latest one is that developed by Mr. Clyde J. Fitch and detailed here. A saving of two tubes as well as an increase of selectivity is obtained with this new circuit called the Tropadyne.

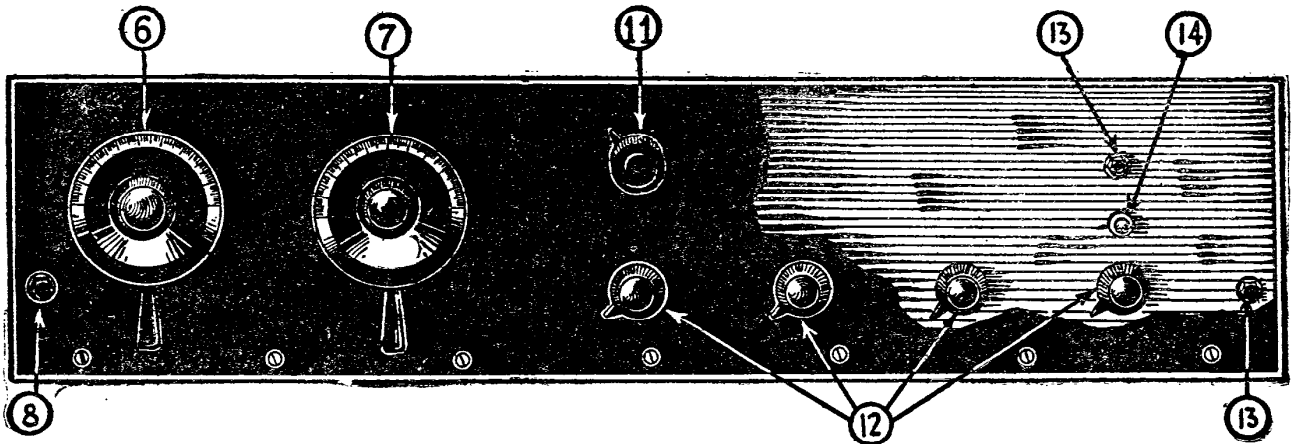

The front view of the completed Tropadyne receiver. The following numbers designate the different controls: 6 is the tuning dial; 7 is the oscillator dial; 8 is the loop jack; 11 is the potentiometer; 12 shows the rheostats; 13 is the detector and amplifier jacks; 14 is the filament switch.

SINCE the original appearance of the first Superheterodyne circuit there have been numerous improvements made in its design. Many of them have been along the line of increased selectivity, others have sought to combine tubes, but this latest one does both. It is well known that a properly constructed receiver involving the Superheterodyne principle will receive more stations with greater clarity and volume on a small indoor loop aerial than any other receiver, no matter what its refinements, using a large outdoor collecting agency. So there is little wonder at the constantly increasing popularity of the Superheterodyne.

Briefly, the Superheterodyne principle involves changing the wave-length of any incoming signal to a certain definite intermediate wave-length. This change in the period of the wave is effected very simply. The user of a regenerative receiving set well knows the squeals and whistling sounds which are heard in his head telephones the instant the receiver is set into oscillation. These squeals are caused by the superimposition of a radio frequency wave generated by the receiver and that of an incoming signal. The two meeting in the detector circuit cause the production of what is termed a beat note, the tone of which is determined by the difference in the two frequencies. The superimposition of the two frequencies is called heterodyning. The heterodyning note can be changed, by shifting the dial, from a very high pitched squeal to a note so low that it passes from the range of audibility. In the Superheterodyne this "squeal" is made above the range of audibility. Nevertheless, all of the audio frequency modulations placed on the carrier wave at the transmitting station are faithfully reproduced at the new radio frequency effected through heterodyning.

It has been found that while making the squeal very high so as to be inaudible, the detector circuit of a regenerative receiver is detuned from the signal, thus decreasing its efficiency and the squeal becomes weaker and weaker as the pitch of the squeal rises. For this reason the

HERE is a remarkable Superheterodyne receiver which we warmly recommend to our readers. It has several new and unusual features. In the first place only six tubes are used giving as much volume as the average eight tube Superhet. The selectivity of this set is unusual. Inequalities of the intermediate transformers have now been done away with by tuning each transformer. After the transformer has been tuned, it can be left this way, no further tuning being necessary.

This system makes for maximum sharpness and maximum volume. Another outstanding point of superiority of the Tropadyne circuit is that it practically does not radiate, thereby not interfering with other nearby receiving stations. Most Superheterodyne circuits, as is well known, are powerful radiators.

standard Superheterodyne employs a separate tube for the oscillator and a separate detector tube to detect the inaudible squeal, also called the beat note. This requires two tubes to do the work of one, which is objectionable. Experimenters have tried using two tuned circuits on the one detector tube, making it a self-heterodyning or autodyning detector. The object was to tune one of the circuits to the signal frequency and tune the other circuit to the oscillating current frequency; but tuning one circuit detunes the other and one finds himself first swinging one dial and then the other and getting nowhere. This disadvantage is entirely overcome in the Tropadyne circuit. The Tropadyne employs a self-heterodyning detector having two independently tuned circuits in the grid circuit of the tube so arranged that tuning one has no effect on the tuning of the other and stations are easily and quickly tuned in. This is the main advantage of the Tropadyne circuit, the elimination of one tube from the standard Superheterodyne circuit.

It was just pointed out that the oscillator and first detector in the Super-

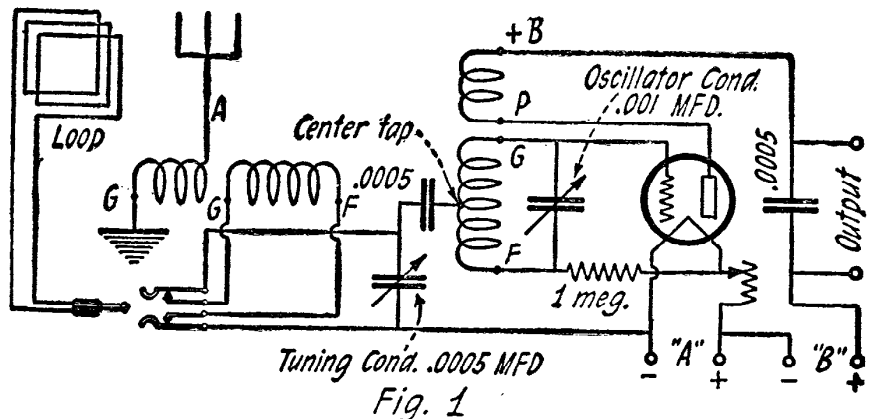

The principle of the Tropadyne circuit is shown here. Although only one tube is used for the detector and oscillator, it will not radiate and will cause no interference to other receiving sets.

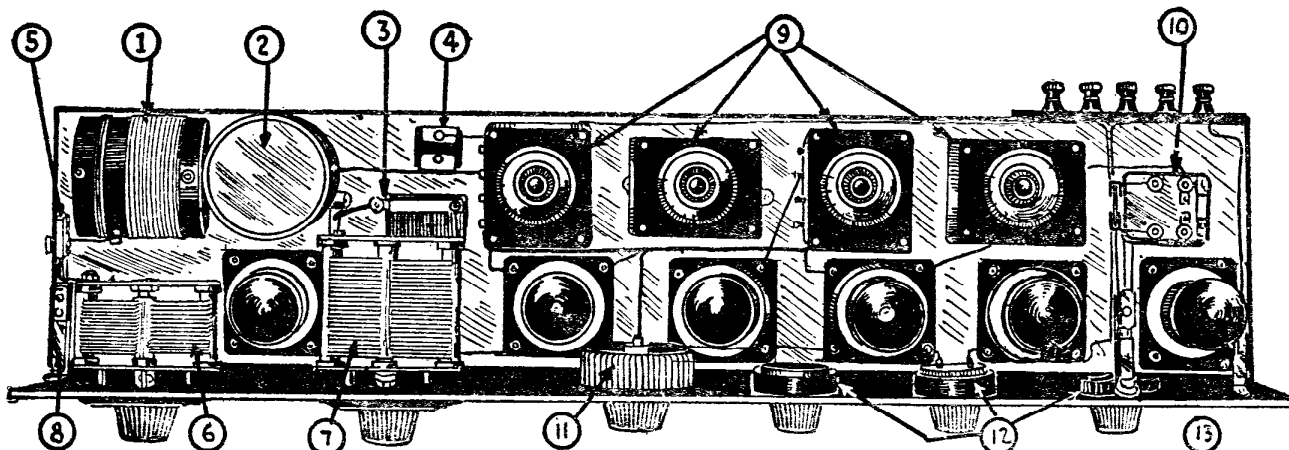

Top view of the Tropadyne showing the neat arrangement of the apparatus. The numbers designate the following instruments: 1, the tuner; 2, the oscillator coil; 3, the grid leak; 4 and 5, fixed .0005 condensers; 6, the tuning condenser; 7, oscillator condenser; 8, loop jack; 9, tuned I. F. transformers; 10, A. F. transformer; 11, potentiometer; 12, rheostats; 13, jacks for detector and loud speaker.

terodyne give a new wave-length or frequency to the signal by producing beats. The two tubes, therefore, act as a frequency changer. In the Tropadyne circuit one tube acts both as oscillator and detector, and is a frequency changer. This is where this circuit gets its name, *tropa* is from the Greek, meaning change, and *dyne* meaning force.

Fig. 1 shows the Tropadyne circuit. Only one tube is shown, which is merely a frequency changer when used in a Superheterodyne receiver, and may be used with any type of Superheterodyne now in existence. As shown in the diagram, it is arranged for both loop and outdoor aerial, the loop being connected in the circuit through a plug and jack. The plate coil, with terminals marked "+B" and "P," is coupled to the oscillator coil, "G," "F" and the tube is continually generating an oscillating current, the frequency of which depends upon the setting of the oscillator condenser. It will be noted that one side of the oscillator coil is connected to the grid of the tube and the other side is connected, through a one-megohm grid leak, to the filament of the tube. The tuning, or loop circuit, is connected between the electrical center, or nodal point, of the oscillator circuit, and the filament of the tube. The grid condenser is placed between the oscillator circuit and the tuner circuit. The electrical center of the oscillator circuit is approximately at the center turn of the coil. In practice, this connection is not critical. It may be two or three turns either side of the center, without seriously decreasing the efficiency.

Although radio frequency currents are flowing in the oscillator circuit, none of this current passes into the tuning circuit since the potential difference between the electrical center of the oscillating circuit and the filament of the tube always remains constant. Therefore, tuning the oscillator circuit has no effect on the tuning of the loop circuit.

The incoming signal current flowing in the loop or tuning coil circuit, is impressed on the filament of the tube and the center of the oscillator coil. The current divides equally at this point, part flowing through the upper half of the coil to the grid of the tube and the remainder flowing through the lower half of the coil to the grid leak. As the signal current divides equally through the oscillator coil, one half flowing in one direction and one-half flowing in the other prohibit current flowing in the oscillator circuit. Both the oscillator and tuning circuits may be tuned independently to the same or different wave-lengths. This is a condition that has never before been attained by a single tube.

There are many variations that may be made with this circuit, employing the same underlying principle, but the arrangement shown gives the best results.

By tuning the loop circuit to the frequency of the incoming signal, the signal current is impressed upon the grid and filament of the vacuum tube. By tuning the oscillator circuit to a different frequency from that of the incoming signal, which current is also impressed on the grid of the tube, a beat note is produced in the plate circuit. This beat note may be audible, depending upon the adjust-

ment of the oscillator condenser. If it is audible, it may be heard in telephones connected to the output terminals. In a Superheterodyne, however, the beat note is made inaudible and is amplified by the intermediate amplifier, which is connected to the output terminals.

It may be well to note that by tuning the antenna circuit to an incoming signal, this signal is impressed upon the grid and filament of the tube and is, therefore, repeated in the plate circuit. By means of the plate coil this amplified signal current is fed into the oscillator circuit and is further amplified by the phenomenon of regeneration. It is assumed in this case that the coupling between the plate and oscillator coils is variable and that the coupling is adjusted to a point just before the tube starts to oscillate. This makes a single tube regenerative receiver and the signals are heard in a telephone headset connected to the output. While adjusting this receiver the tube will sometimes generate an oscillating current in the oscillator circuit. But, as stated before, none of this current passes into the antenna circuit and hence this one-tube regenerative receiver is non-radiating. Some engineers have proven mathematically that if it is possible to transfer a radio frequency current from a primary circuit to a secondary circuit, the action is also reversed and a radio frequency current flowing in the secondary circuit will be transferred to the primary circuit. They have, therefore, stated that the only possible way to prevent an oscillating regenerative receiver from radiating into the antenna is by the use of a blocking tube a

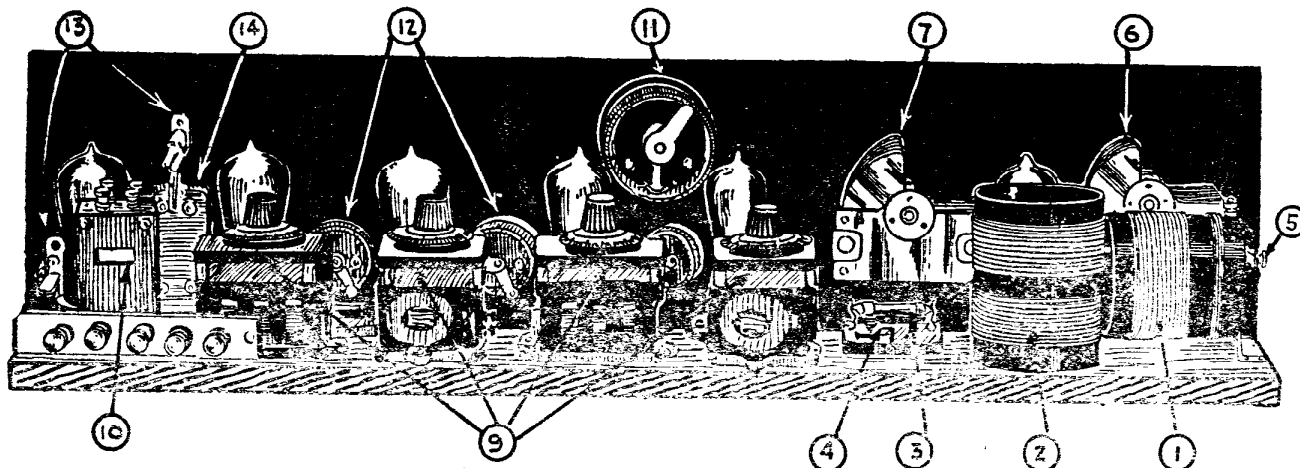

Rear view of the Tropadyne receiver. The spacing of the I. F. transformer coils can be clearly seen. The numbers and instruments correspond to those shown in the upper illustration.

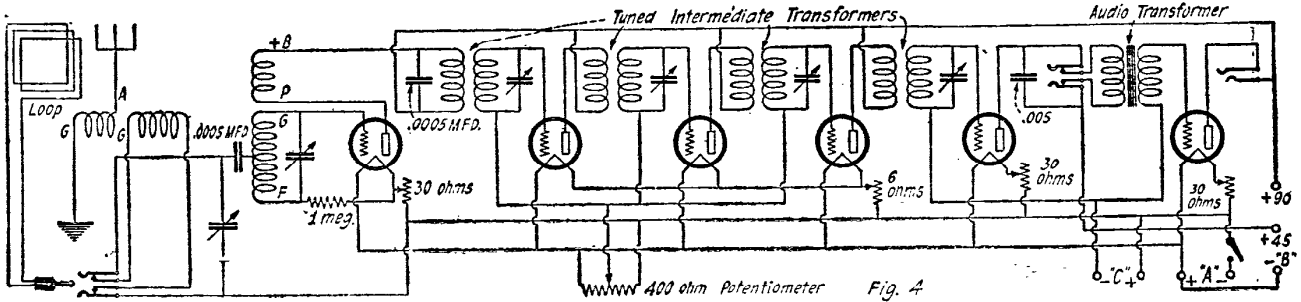

Schematic diagram of the Tropadyne circuit. Although only six tubes are employed, it compares favorably in volume with the ordinary Superheterodyne using eight tubes.

hypothesis disproved by the Tropadyne. Since the object of regenerating in a receiving set is to apparently nullify the resistance of the antenna circuit, if the set does not regenerate into the antenna the efficiency, as far as DX reception is concerned, is greatly impaired. Therefore, it is doubtful if the one-tube non-radiating regenerative set will become very popular. Of course the sensitivity can be increased by employing one or two stages of radio frequency amplification before the regenerative detector tube.

Figs. 2 and 3 show the complete details of the antenna coupler and the oscillator.

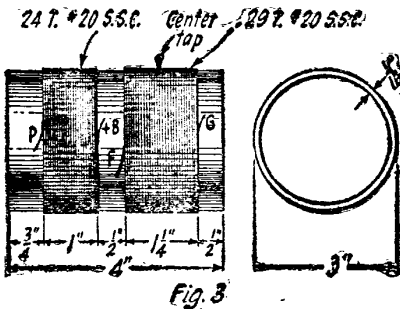

Details of the oscillator coil. The plate and grid coils have 24 and 29 turns respectively.

coil. The drawings are self-explanatory and need not be described here. The end connections of the windings are lettered according to the lettering on the diagram, Fig. 1. In the diagram the coils are shown reversed in order to simplify the diagram; that is, the terminals "P," "G" of the oscillator coil are shown adjacent to each other in the diagram, whereas actually they are at opposite ends of the insulating tube. The object of bringing these leads out at opposite ends of the tube is to decrease the electrostatic capacity between the plate circuit and the grid circuit of the tube.

These two coils should be constructed according to the drawings and mounted as shown in the illustrations. At the right of the (rear) picture are shown the tuning condenser, oscillator condenser and antenna and oscillator coils. The frequency changer tube, which is the one shown in Fig. 1, is placed between the two condensers. This arrangement makes the connections very short.

The accompanying illustrations also show the intermediate amplifier and the audio amplifier. The set shown has six tubes, the first of which is the frequency changer, and the next three the three-stage intermediate amplifier. The fifth tube is detector and the sixth is a one-stage audio frequency amplifier. For most purposes one stage of audio frequency amplification is sufficient, although for volume on DX stations, two stages are recommended.

The set shown has a 7 x 30-inch panel.

This allows ample room for wiring. Although it is not advisable to crowd the instruments of a Superheterodyne, it is possible to mount a seven-tube set on a 30-inch panel. The two condensers, one potentiometer, four rheostats, three telephone jacks and a filament switch are mounted on the panels. The illustrated layout may be changed to suit individual requirements.

The Tropadyne principle, described above, is shown in Fig. 4 as incorporated in the complete six-tube Superheterodyne circuit. This circuit, with the exception of the connections of the first tube, is similar to the standard circuit. It will be noted, however, that no grid condenser and grid leak are used for the second detector. It has been found that a vacuum tube detector distorts signals, especially if they are very strong. This distortion has been practically eliminated from the second detector by operating the tube on the lower bend of its characteristic curve. This is accomplished by connecting the grid return lead to the negative side of the "C" battery, which acts as a grid bias for the audio amplifier tube. This applies a negative potential to the grid of the detector and, therefore, very little or no current is absorbed by the detector, and the selectivity of the intermediate amplifier is considerably improved. With a "C" battery of nine volts and a plate voltage of 45, the selectivity is so great that powerful local stations, otherwise broad in tuning, are tuned in and out with the vernier alone. This battery does not decrease the volume and the quality of reproduction is remarkable.

The question of air core or iron core intermediate frequency transformers is a much mooted one. While the air core type is very selective, it requires condensers for tuning each stage of amplification to the same wave-length. Usually fixed condensers are employed for this purpose, but it is difficult to obtain fixed condensers of uniform capacity and the result is that the amplifier operates at two or more wave-lengths. When this occurs, the same station is received at several settings of the dials. Iron core

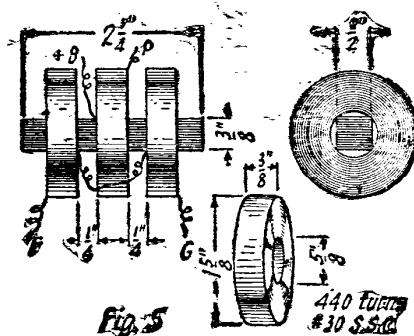

The construction of the iron core intermediate transformers. Note spacing of coils.

transformers, on the other hand, are very broadly tuned and give higher amplification than air core transformers. These transformers are so broad in tuning, however, that it is difficult to receive DX stations while local stations are operating. Manufacturers of iron core transformers usually supply one air core transformer, tuned by fixed condensers, for use in either the first or last stage of amplification. This air core transformer (often called a coupling, or filter transformer) is supposed to make the amplifier more selective, a situation not always obtained in practice. These disadvantages have been overcome by using the semi-iron core intermediate frequency transformers which are shown in Fig. 5.

The complete details of this transformer are shown in the illustrations. It will be noted that a variable condenser is permanently mounted on each transformer. This condenser is connected across the secondary winding and in this way each transformer may be accurately

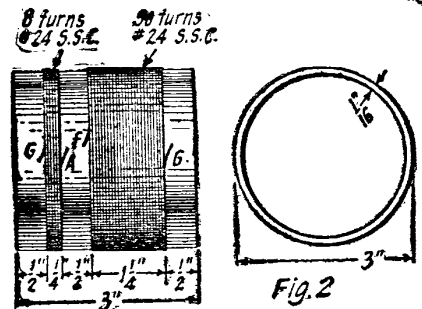

A coupler having an untuned primary is used. Both primary and secondary are wound on the same tube.

tuned, making the intermediate frequency amplifier very selective and efficient. "Rico" mica insulated variable condensers are used because they occupy less space than those employing air dielectric. These condensers have a maximum capacity of .0005 mfd. and, in connection with the coils used, the transformers may be tuned to any wave-length ranging from 2,000 to 7,000 meters. Although the coils used in these transformers were wound by machine, they may easily be wound by hand, haphazardly, on a suitable form, or spool. The number of turns, which in this case was 440 in each coil, is not critical. Two coils connected in series form a secondary and one coil forms a primary. It is important to separate the coils at least 1/4 inch. The core iron used is exceptionally thin, japanned silicon steel. This steel may be obtained from manufacturers of iron core radio frequency transformers and is not the same as that used in the construction of audio frequency transformers. When constructing these transformers, it is important that all coils be wound in the same direction and placed

on the core, as shown in the illustrations. The leads are lettered to correspond to the vacuum tube connections.

As stated before, the Tropadyne principle may be incorporated in any Superheterodyne receiver. Those who already have a seven or eight-tube Superheterodyne may take but one tube by changing over to the Tropadyne circuit and in doing so may improve the efficiency and decrease the operating expense of the set. Some experimenters have reported phenomenal results by converting this tube into a one-stage short wave radio frequency amplifier before the first detector instead of removing it entirely. For ordinary purposes, such extreme amplification is not recommended.

If the six-tube Tropadyne receiver has been built according to the specifications given, little trouble should be experienced in operating and tuning distant stations. After the construction of the set has been completed the tuned inter-

mediate transformers should be adjusted for maximum efficiency. This is accomplished by tuning in a nearby station that comes in loudly. The dials of the transformers should all be set at about 80 degrees. After the station is tuned in with the oscillator and tuning condenser, the potentiometer should be turned towards the positive side of the filament until the amplifier does not oscillate. Leave the last transformer set and slowly turn the dials of the others, one at a time, and leave them set at the positions in which the station is received at its loudest. It may be necessary to change the setting of the oscillator dial slightly after adjusting the transformers. It will be noticed that the adjustment of the transformers is not very critical when receiving loud local stations, but is very critical when receiving distant stations. It is well to adjust the transformers again after tuning in a DX station. Once the transformers are adjusted they need

not be changed. Should the oscillator squeal when the dial is turned toward the minimum, the oscillator filament rheostat should be turned down slightly. 201A tubes are recommended.

Practically as good results may be obtained from this set when using a loop aerial as when using an outdoor aerial, but as many already have outdoor aerials, it is well to build the antenna coupler into the set. A 15- or 20-foot indoor aerial gives excellent results with this circuit and occupies less room than a loop. In regard to the sensitivity of this set, it has been compared side by side with other Superheterodyne sets employing more tubes and the Tropadyne was not only more selective, but received the distant stations just as loudly and clearly as the other sets. The sensitivity of the six-tube Tropadyne set was found to be practically the same as that of other seven tube Superheterodyne receivers.

Matching Intermediate-Wave Transformers For Superheterodynes

(Continued from page 37)

Method of Measurement

The oscillator is set for the frequency desired by means of the calibrated dial of Cv. Its filament switch should then be opened to render it inactive. The tubes T1 and T2 should then be lighted with the transformer T in place. The potentiometer arm should be placed over to the positive side as far as it will go. The switch S1, which short-circuits the high-range milliammeter, should then be opened. MA1 will indicate several milliamperes of current flowing through the plate circuit of T2. The movable contact of the potentiometer should then be moved toward its negative terminal, thus placing increasing negative bias on the grid of T2. The reading of MA1 will gradually fall off as the potentiometer arm is moved, since a negative bias on the grid reduces the plate current of the vacuum tube. When the plate current is reduced to the safe limit of MA2, the switch S2 should be opened to place this instrument in the circuit. Adjustment of the potentiometer should then be continued until the reading of MA2 is reduced practically to zero. The reading of the voltmeter V should then be noted, calling this reading V1.

The adjustment already made should now be left as they are and the filament of the oscillator tube lighted to the point where oscillations begin. This will cause an oscillating potential to be impressed on the grid of tube T1, and will cause an oscillation ripple to be impressed on the plate current to that tube. The transformer windings transfer this oscillation to tube T2. This oscillating ripple in the grid circuit of tube T2 is superimposed on the steady grid potential maintained by the battery Bp and the potentiometer P, as indicated in Fig. 3. It is now seen that the potential of the grid tube T2 is not maintained at the point V1 required to block the action of the tube, but rises above this value part of the time as at A, Fig. 3. This causes some plate cur-

rent to again flow through the milliammeters and a further adjustment of the potentiometer will now be needed to again reduce the plate current of tube T2 to zero. The reading of the voltmeter V should now be noted, calling this reading V2.

The quantity, V1-V2, is an indication of the amplification constant of the transformer under test at the frequency for which the oscillator was set. The amplification curve plotted from these determinations will have the general appearance of Fig. 4. By an inspection of this curve, the best frequency for use with this transformer will be learned. In Fig. 4, this optimum frequency is 9,600 meters, or 31,300 cycles per second.

The amplification curves for the other transformers to be used in the set should now be plotted in the same way. It will usually be found that, even with transformers made to the same specifications, the peaks will not occur at exactly the same frequency. The different transformers may often be made to peak at the same frequency by removing or adding turns to both the primary and secondary windings. This adjustment should be made by trial, adding or removing turns until the desired peak is obtained.

The results secured by this test are sufficiently close to secure a high efficiency in the selection of a set of matched transformers. The increased efficiency in reception will more than pay for the efforts required for testing and matching the transformers. Many manufacturers are now offering sets of matched transformers which have been matched by a method very similar to that described.

The test outlined may be improved by placing a buzzer in the grid circuit of the oscillator and using a headset in connection with an audibility meter to replace the milliammeters. The modulated continuous waves from the oscillator will cause the sound of the buzzer to be heard in the headset. The audibility

meter should then be adjusted so that the sound is reduced to the proper standard. The data so obtained will permit the optimum frequency for the transformer under test to be more closely determined thus improving the efficiency of the test.

The Most Novel Superheterodyne

(Continued from page 36)

are bridged across the output of the oscillator when it is on the job as such. When it is not oscillating, the click will not be noticed.

The potentiometer adjustment allows considerable leeway in changing the oscillation frequency of the zincite-steel combination. A Victrola needle pressed tightly against a zincite crystal gave the best preliminary result.

Filing off the crystal or digging out a small pit in which to seat the steel point gets better and more positive results.

The theoretical considerations involved in the operation of this type of oscillator are too broad to be gone into in a short article such as this. The solution of the practical side can only be accomplished by continued changes, and cut-and-try methods.

Zincite as a crystal is subject to widely fluctuating conditions. One piece will respond without any battery excitation at all. Another will be sluggish until it is jolted by a short circuiting across an "A" battery. Some will have to be baked in an oven and the blackish impurities scraped off, such as zinc sulphide. Zincite itself is ZnO, or zinc oxide, an orange-red colored mineral in a granular form, sometimes showing layers and strata.

How to Build the Popular Mechanics' Superheterodyne Eight

An Ultra-Sensitive Radio Receiving Set

REPRESENTING the closest approach to perfection yet attained, the Superheterodyne circuit well deserves its widespread popularity. It is the general opinion of radio experts that any advancement will not come until some discovery is made that will upset present methods of radio communication.

The Superheterodyne receiver described herewith by F. L. Britain in *Popular Mechanics Magazine* embodies all the most advanced ideas pertaining to this circuit. Nothing has been overlooked that would add to the efficiency of the instrument. Every piece of apparatus used in its construction has been carefully selected and thoroughly tested by the author, and the completed instrument

seemingly leaves little to be desired in selectivity, range and clarity of tone. All body-capacity effects have been eliminated by simple shielding, and the instrument is easily tuned, even by a novice, after a few minutes of instruction. The receiver can be built at a fraction of the cost of similar manufactured instruments, and has many refinements not yet included in the Superheterodyne receivers on the market.

Any radio fan can build this instrument, with a few simple tools, if the directions are closely followed. All parts are standard, and easily obtained from any dealer in radio supplies. There are many good instrument kits on the market for the construction of Superhetero-

dyne receivers, but the instruments in such kits are intended for operation in a circuit especially designed by the manufacturer. Such kits should not be purchased with a view to using the instruments in the circuit described here, as any departure from those specified herein will result in loss of the perfect balance that is absolutely necessary in this type of receiver. The Superheterodyne circuit employs a force that is extremely sensitive, and at the same time powerful, and cannot be compared to any other type of circuit.

Before attempting to build the set, read this article carefully. Obtain all the parts, even to the smallest items, such as screws, wire, lugs, etc., before starting actual construction. (See Page 44.) By doing this, you will find every step described much easier to follow. Equip yourself with a good small electric soldering iron, a small tin of non-acid soldering paste, and a coil of solid-wire solder. It is essential that all connections be soldered, using lugs under all binding posts, and also under all terminal posts of sockets, rheostats, voltmeters, and transformers. Screw these lugs down tightly and solder the connecting wires of the circuit to them; use very little soldering paste, and wipe it on carefully before applying the solder; the paste is used more to clean the surface than to act as a flux, and a very thin film is sufficient. The paste has a tendency to run under the terminal posts and make poor connections unless this precaution is taken. This advice is given in advance of all other construction details because poorly soldered connections will cause failure, even if every other detail is followed exactly.

Some of the tools necessary are as follows: A pair of long-nosed pliers; blunt-nosed pliers; small side-cutting pliers; a small screwdriver; a heavy screwdriver; a small hacksaw; a hand drill; a center punch and a scriber. An ice-pick makes a good and easily obtained tool for this purpose. Do not make marks on the panel with a lead pencil.

Refer now to the drawing of the front-panel template. Obtain some heavy cardboard, such as bristol board, to make this. It is always best to make a template of the front panel so that the holes for mounting the various instruments can be properly located. The panel is of hard rubber or Bakelite, 7 by 26 by 3/16 in. in dimensions. Lay the panel on the bristol board and carefully outline it; then cut the bristol board to the exact size of the panel. On the template thus made locate the position of the holes for mounting the various instruments. Lay out this template exactly as shown in the drawing. In the template drawing the oscillator condenser is shown at the left of the panel, and the wave-length condenser to its right.

Be sure that the panel template is laid out exactly in accordance with the drawing as any departure from it will result in trouble later on.

After the template is completed, lay it on the panel and clamp it at the edges with small C-clamps, so that the template cannot shift on the panel while locating the holes for the instruments. Now, with the center punch or icepick,

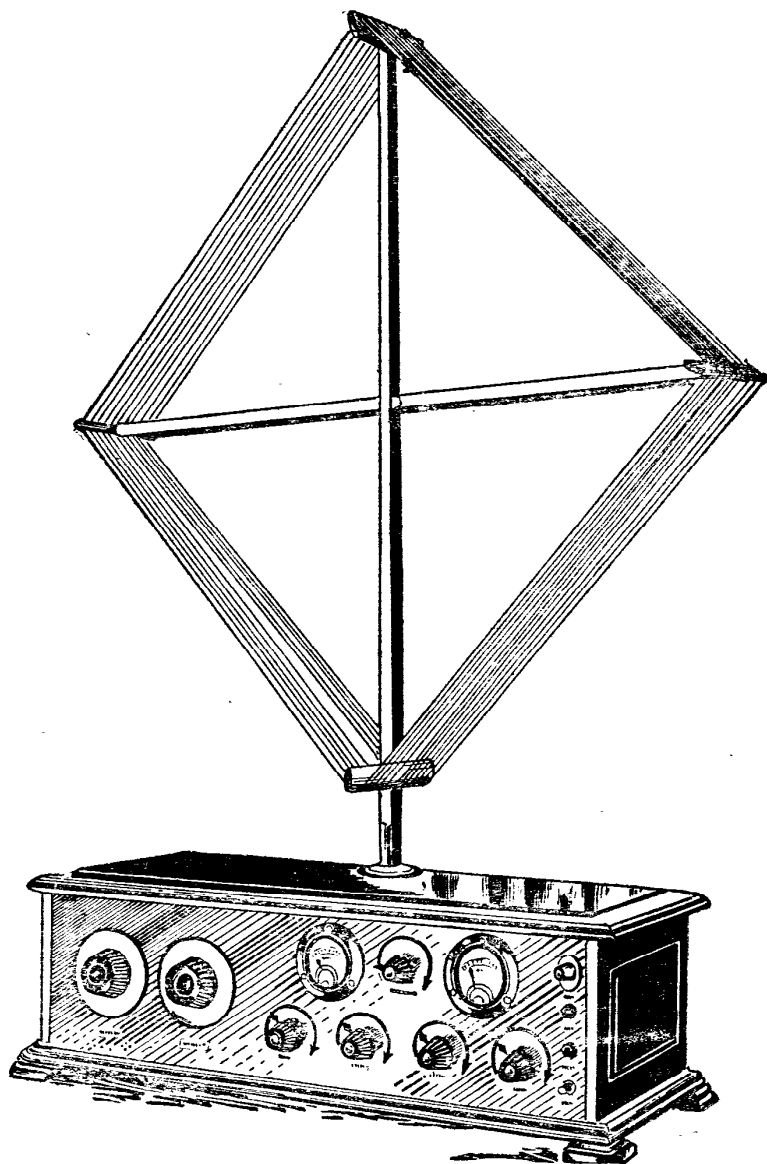

Illustrations by Courtesy of
Popular Mechanics (Chicago, Ill.)

A view of the completed Superheterodyne Receiver, with collapsible loop extended and plugged into the jack in the cabinet lid.

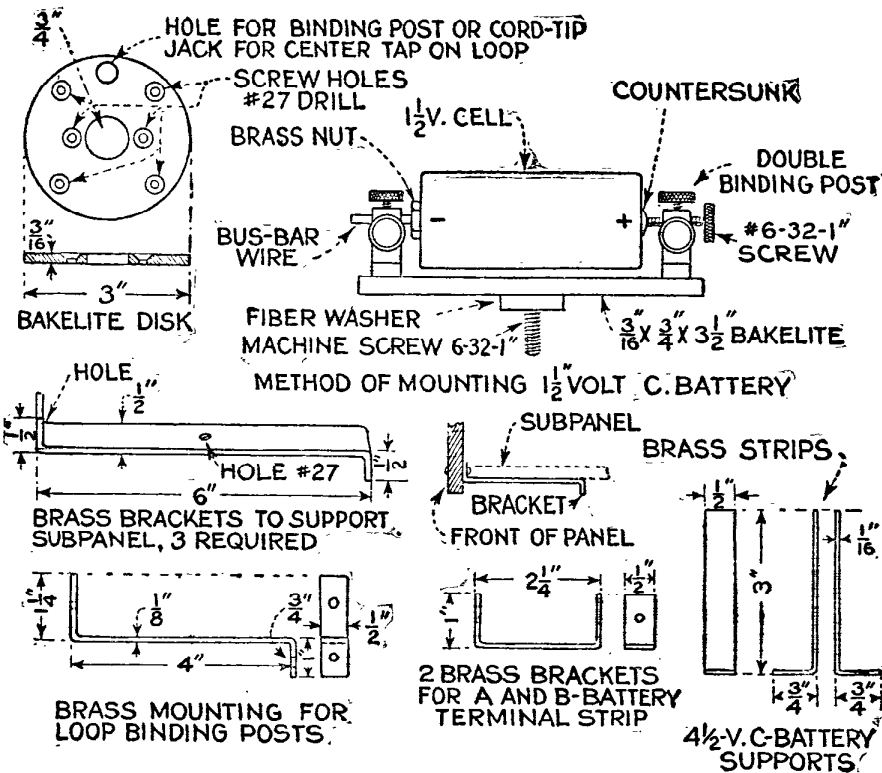

Various constructional details; method of mounting flashlight cells, disk for loop mounting, binding posts, C-battery and subpanel brackets.

carefully mark the center of each hole through the template into the panel; make each mark in the panel deep enough so that no errors will be made when drilling, then remove the template from the panel. Always drill the panel from front to back, never from back to front. It will be noted that the oscillator and the wavelength condenser holes, shown with the double circle, are to be countersunk for machine screws. A No. 27 drill is used for all screw holes, and an 11/32-in. drill for the shafts of the condensers and rheostats. The rheostats are of the new single-hole mounting type, and have a little projection at the outer edge, on the side that goes next to the panel. This point is for the purpose of preventing the rheostat from turning out of position; drill a small hole part way into the rear of the panel to fit it, being careful not to drill the

hole any deeper into the panel than is necessary to take the point and permit the rheostat to lie flat against the panel. The rheostats are mounted with the terminals up, to facilitate the wiring of the circuit. The potentiometer is mounted in the same manner as the rheostats, except that the terminals are turned down. After the rheostats are fitted to the panel, remove them. Now drill the holes for the voltmeters; this will not be easy unless one is equipped with an expanding or wing bit. It will be best to have these holes drilled in the local machine shop. It is necessary first to make the the 3/16-in. cut-out at the lower edge of the hole for the voltmeter; this is done with a 3/8-in. drill, right on the line of the larger hole, and the latter, 2-9/16 in. in diameter, is then drilled. The 3/16 in. cut-outs are to take the shafts of the little pointers and switches on the volt-

eters. Place the voltmeters in the holes and mark off the mounting-screw holes. The exact location of these holes will be found when the voltmeters are fitted into place on the panel; care should be taken in marking and drilling them so that the voltmeters will be lined up correctly when the screws are placed in position. Use a No. 27 drill for the holes and nickel-plated screws for mounting the voltmeters. They provide a check on the condition of the A- and B-batteries at all times and prevent using excessive filament voltage.

In the upper right-hand corner of the panel will be found the 3/4-in. hole for mounting the red pilot light; the socket for this is of a standard nickel-plated auto dash-light type and mounted on the front of the panel. The lamp is a 2-cp. 6-volt double-contact bulb, and can be had in colors; this lamp is lighted whenever the instrument is in operation and reminds the operator not to leave the instrument without first cutting off the A-battery from the tubes; this feature will be appreciated by anyone who has inadvertently left his tubes lighted, and returned later to find his A-battery run down. The screw holes above and below the 3/4-in. hole are for the nickel-plated machine screws used to mount the pilot lamp-socket.

Directly below the pilot lamp are the holes for mounting the horn jack, and lower down, the hole for the phone jack; these holes are 7/16 in. in diameter. The horn jack is of the filament-control type, and the second audio-frequency amplifying tube remains unlighted until the plug from the horn or loud speaker is pushed into the jack. The author has found it unnecessary to use the loud speaker in the horn jack on many stations, even some 500 or more miles away, because the volume obtained when the loud speaker is plugged into the phone jack is more than sufficient; there is really more amplification than one knows what to do with, unless the instrument is detuned. For extremely distant stations however, the second step in audio-frequency amplification can be used to good advantage. The phone jack is of the open-circuit type. The hole for mounting the push-pull filament switch is located directly below the phone jack; this hole is drilled with the 11/32-in. drill. Use the No. 27 drill for the holes at the lower edge of the panel, to mount the brass brackets that support the bakelite sub-panel. The drilling of the front panel is now finished. If there are any instruments mounted on this panel, re-

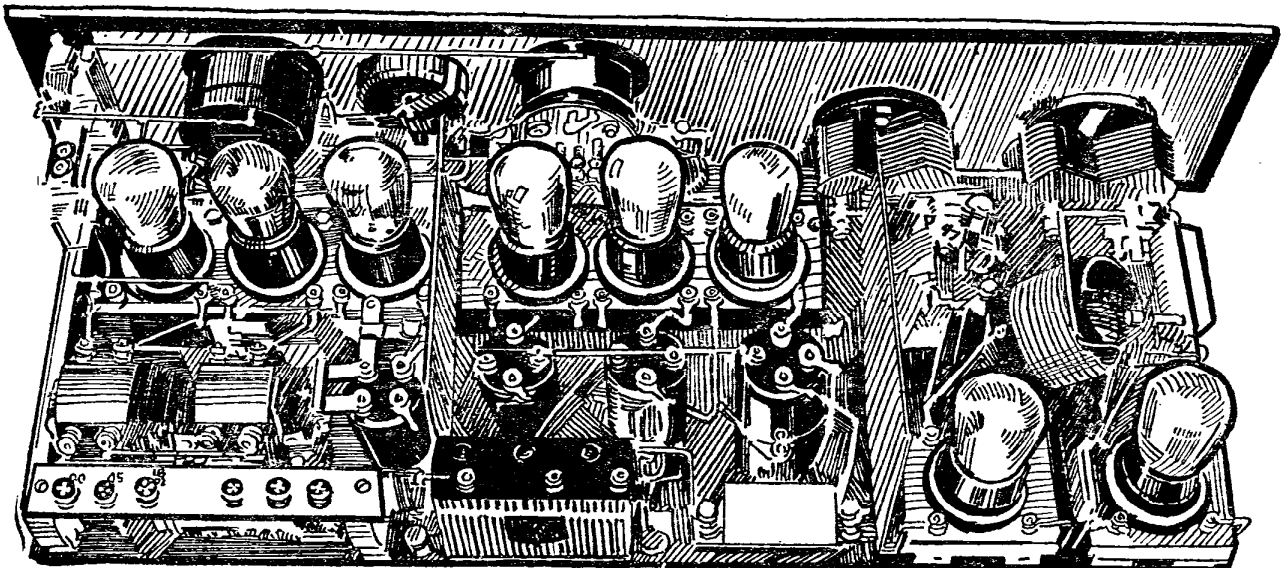

Rear view of the Superheterodyne Eight. Notice how compact the layout is arranged and the method of shielding with brass plates.

move them, and the panel is ready for engraving; this can be dispensed with, if desired, and transfers or other markers used; however, engraving adds much to the appearance of the completed instrument, and good work can be obtained in most any city for from 3 to 5 cents a letter; for the arrows around the rheostat knobs the cost is from 12 to 15 cents each.

The next step after the panel has been engraved, and the builder has made sure that all holes have been drilled, and that those so marked have been countersunk, is to fit the sheet of tinfoil on the back of the panel. This tinfoil sheet is 6 by 24 in. in size; coat one side of the foil with a good grade of orange shellac and stick it on the back of the panel. The foil should be placed on the panel $\frac{1}{4}$ in.

from the end where the oscillator and wave length condensers are to be mounted, and $\frac{1}{2}$ in. from the top and bottom of the panel; it will now reach across the panel to a point about $1\frac{3}{4}$ in. from the other end; this is clearly seen in the picture of the rear panel assembly. The front panel is then completed.

The brass brackets for supporting the sub-panel are then screwed to the lower

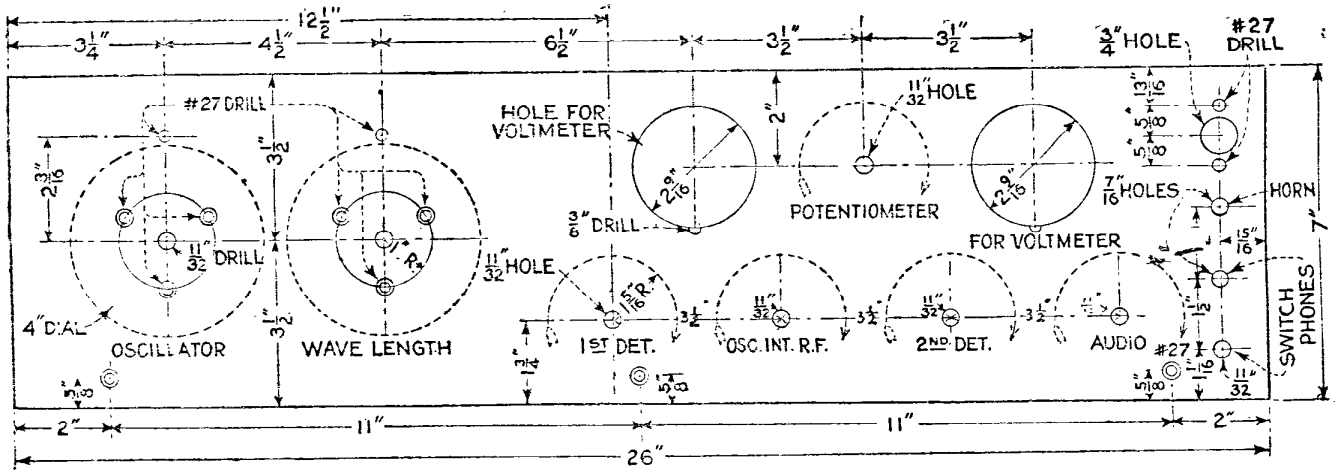

Layout template for drilling the front panel. This can be measured off on a sheet of bristol board to the given dimensions.

LIST OF PARTS AND MATERIALS REQUIRED

1 3 16 by 7 by 26 in. radion panel mahoganized (or black)	\$ 4.00	1 No. 601 Dubilier micadon condenser .0005-mf., with grid-leak clips	.45
1 $\frac{7}{8}$ by 9 by 25 in. formica or bakelite sub-panel	3.38	1 No. 601 Dubilier micadon condenser .00025-mf., plain	.35
3 No. 600 Remler intermediate-frequency transformers	18.00	1 Dubilier by-pass condenser .5-mf.	.90
1 No. 610 Remler tuned-stage transformer	6.00	1 Dubilier by-pass condenser 1-mf.	1.25
2 No. 631 Remler .0005-mf. capacity units (variable condensers), complete with dials	10.00	1 Daven grid leak, 2 meg.	.50
1 No. 620 Remler coupling unit	3.00	2 $1\frac{1}{2}$ -volt flashlight cells	.40
2 No. 619 Frost shock-absorber sockets, 3-gang type, standard base	6.50	1 bakelite disk $\frac{3}{16}$ by 3 in. in diameter	.15
2 No. 618 Frost shock-absorber sockets, single, standard base	2.50	1 auto dash-light socket, nickel, flush-mounting type	.35
1 No. 651 Frost vernier rheostat, 6-ohm, single-hole mounting type	1.25	1 auto lamp, 2 cp., 6-volt (red if possible)	.30
2 No. 650 Frost rheostats, 6-ohm, single-hole mounting type	2.20	1 strip of bakelite, $\frac{3}{16}$ by 1 by 7 in.	.14
1 No. 657 Frost rheostat, 25-ohm, single-hole mounting type	1.25	2 strips of bakelite $\frac{3}{16}$ by $\frac{3}{4}$ by $3\frac{1}{2}$ in.	.16
1 No. 654 Frost potentiometer, 400-ohm, single-hole mounting type	1.25	6 binding posts, Eby type, with engraved tops for A and B-batteries	1.20
1 No. 233 Frost jack, open-circuit type	.70	5 binding posts, plain	.50
1 No. 235 Frost jack, filament-control type	.95	20 2-foot lengths of tinned-copper bus-bar wire	.75
1 No. 608 Frost push-pull filament switch	.30	15 3-foot lengths of good-grade black spaghetti tubing	1.80
1 No. 250 Frost loop jack and plug complete	1.50	7 doz. tinned-copper lugs, long type, round hole	.70
1 No. 850 Chelton midget variable condenser .000045-mf., table-mounting type	1.75	1 strip of bakelite, $\frac{3}{16}$ by $\frac{5}{8}$ by $2\frac{1}{2}$ in.	.06
2 R-12 All-American audio-frequency transformers, ratio 3 to 1	9.00	4 double binding posts	.40
1 No. 55 Jewell voltmeter 0-8 volts, d.c., three-circuit type	10.00	1 sheet tinfoil, 6 by 24 in.	.10
1 No. 55 Jewell voltmeter, combination A and B, 0-10 and 0-100	10.00	2 brass sheets .016 in. thick, $6\frac{3}{4}$ by $6\frac{1}{2}$ in.	.40
1 Mathieson collapsible loop, three-terminal type	12.50	3 brass brackets $\frac{1}{8}$ by $\frac{1}{2}$ by 7 in.	.45
1 No. 601 Dubilier micadon condenser .006-mf.	.75	1 brass bracket $\frac{1}{8}$ by $\frac{1}{2}$ by 6 in.	.10
3 No. 601 Dubilier micadon condensers .0025-mf.	1.20	2 brass brackets $1/16$ by $1/2$ by $4\frac{1}{2}$ in.	.15
		1 $4\frac{1}{2}$ -volt Burgess C-battery	.40
		8 $6/32$ brass machine screws, $1\frac{1}{2}$ in. long, with nuts	.10
		2 $6/32$ brass machine screws, 1 in. long, with nuts	.05
		15 $6/32$ brass machine screws, $3/4$ in. long, with nuts	.15
		26 $6/32$ brass machine screws, $1/2$ in. long, with nuts	.30
		6 wood screws, nickelplated, oval head, 1 in. long	.10

part of the panel and make contact at this point with the foil, for grounding the shield; these brackets are made from $\frac{1}{8}$ -in. brass strip, $\frac{1}{2}$ in. wide and 7 in. long. A $\frac{1}{2}$ -in. bend is made at each end in the manner shown in the detail drawing. There are three of these brackets, and holes for the machine screws used to mount the panel on the brackets are drilled through the upturned end of each, using a No. 27 drill. A hole is also drilled through the center of each bracket for the short $\frac{1}{2}$ -in. machine screws used to mount the subpanel on the brackets. The turned-down ends of the brackets then form supports for the subpanel and rest on the bottom of the cabinet; the brackets hold the subpanel $\frac{1}{2}$ -in. above the bottom of the cabinet and permit wiring under the subpanel. Remember that the subpanel is not yet mounted on the brackets; the latter are supporting the front panel by means of machine screws through the upturned ends; the screws used have flat black-japanned heads, and are counter-sunk flush with the front of the panel. The brackets act as a support for the front panel and all the instruments of the latter can now be mounted in their proper positions, after soldering lugs have been placed under all the instrument terminals. The foil will stick tightly to the panel and effectually shield the instrument from any hand capacity when tuning. Before the shellac has had time to dry hard, cut away the foil from around the instrument-mounting holes (a safety-razor blade is handy for this purpose); be sure that the foil does not touch any of the instruments when they are mounted on the panel. The writer used a 3-in. square of mica between each of the rheostats and the panel, and also between the potentiometer and the panel. Thin mica sheet was used, and a hole sufficiently large for the shafts of the instruments cut with the points of a pair of dividers. This is an extra precaution, but insures that no metal on the rheostats or potentiometer will come in contact with the foil. Use a little alcohol for removing any traces of shellac remaining on the panel.

The subpanel can be either formica or bakelite, $\frac{7}{8}$ by 9 by 25 in. in dimensions;

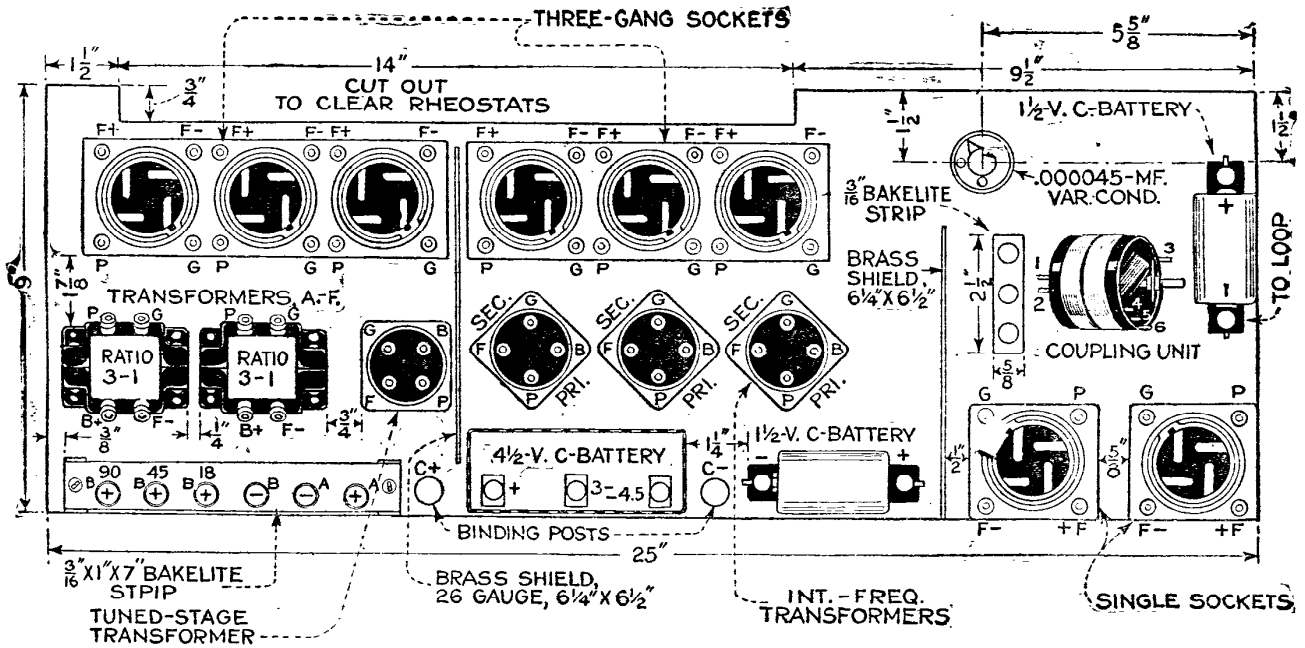

Layout of the subpanel, showing the location of the various parts, giving dimensions for placement.

refer to the subpanel layout and note the cut-out, $\frac{3}{4}$ -in. deep and 14 in. long; this is to clear the lower part of the rheostats mounted on the front panel. A small cut-out will also be necessary at the left front end of the subpanel, to clear the back of the push-pull switch; the size of this can readily be determined upon assembly. Assemble the various instruments on the subpanel and use a scriber to locate the mounting holes. All holes in the subpanel can be drilled with a No. 27 drill. Be careful to locate the various instruments on the subpanel exactly as shown in the layout. Note that two three-gang sockets are used. The first socket unit at the left is for the second detector and the two audio-frequency amplifying tubes; the two audio-frequency amplifying transformers are placed directly back of their respective tubes. These transformers have a ratio of 3 to 1 and are so placed that the grid and plate terminals are as close as possible to the respective grid- and plate-terminals of the tube sockets, which allows short and direct leads. This precaution should be taken with all the transformers in regard to the plate and grid leads. The tuned-stage transformer is placed next to the first audio-frequency transformer. On this transformer will be found three little mounting brackets placed under the terminals; the .00025 mfd. fixed condenser is connected against the grid and filament posts on two of these brackets; the third bracket is also placed under the grid terminal and provides a mounting for one side of the .0005-mfd. grid condenser and the 2-meg. grid leak, which is mounted on clips attached to the grid condenser. This assembly is clearly shown in the wiring diagram. Place soldering lugs under every terminal on transformers and sockets, and also put lugs on all fixed condensers not furnished with them. These lugs can be attached to the condensers by means of short brass machine screws. Never solder directly to any condenser of this type, as the heat from the iron will destroy the efficiency of the condenser.

The .5-mfd. by-pass condenser is placed flat under the second detector-tube socket, with the terminals toward the front panel, making connection easy to the lever of the potentiometer and the

negative-A line. Directly back of the audio-frequency transformers, at the back edge of the subpanel, mount the brackets for supporting the terminal strip. These are made of $\frac{1}{16}$ by $\frac{3}{4}$ by $4\frac{1}{4}$ -in. brass strips, turned up 1 in. at each end and drilled as shown in the accompanying illustration of the detailed bracket pieces. Fasten them to the subpanel with brass machine screws. The terminal strip consists of a piece of $\frac{3}{16}$ by 1 by 7-in. bakelite. Drill this strip for the binding posts and engrave the various B-battery voltages as indicated on the strip. Place soldering lugs under these posts and mount the strip on top of the brackets with short brass machine screws. The 1-mfd. by-pass condenser is connected across the B-battery from the A negative to B 90-volt posts. At the right of the terminal strip is a binding post on the subpanel; this post is for the positive lead of the $4\frac{1}{2}$ -volt C-battery. A lead from the negative A-battery line is also run to the base of this post under the subpanel. This binding post is for the convenience in wiring; the lead from the negative-A line to the positive of the C-battery can be taken direct, eliminating the binding post if so desired. This completes the assembly of this section on the subpanel. A brass shield is then placed between this section and the next, as shown in the subpanel layout and rear view of the set. The shield is made of 26-gauge sheet brass, $6\frac{1}{4}$ by $6\frac{1}{2}$ in. in size. The long side is bent at right angles $\frac{1}{4}$ in. from the end, to form a mounting base for the shield; two holes are drilled through the flange, and the shield is secured to the subpanel with short machine screws. A soldering lug is placed under one of the machine screws on the underside of the subpanel for the purpose of grounding the shield. This applies to both shields and the tinfoil shield on the back of the front panel is grounded by means of lugs under the brass supporting brackets that go under the subpanel. The lugs are all connected together with one wire which runs to the negative binding post of the A-battery. This is done after all circuit wiring has been completed.

We will now consider the middle section; this embraces the three intermediate-frequency transformers and their respective tube sockets, also the $4\frac{1}{2}$ -volt

C-battery, the $1\frac{1}{2}$ -volt C-battery for the potentiometer and the negative lead to the filament posts of the intermediate-frequency transformers. The filament posts of these transformers are all connected together with one bus bar, and this lead is taken to the negative post of the $1\frac{1}{2}$ -volt battery. The binding post shown between the two C-batteries in this section is for the negative lead from the $4\frac{1}{2}$ -volt C-battery, which goes to the filament posts of the two audio-frequency amplifying transformers. The $1\frac{1}{2}$ -volt C-battery consists of a cell from a flashlight battery, and is mounted on a $\frac{3}{16}$ by $\frac{3}{4}$ by $3\frac{1}{2}$ -in. strip of bakelite. Holes are drilled at each end of the strip for mounting double binding posts, of which the lower screws secure the leads from the circuit, and the upper ones hold two short lengths of bus bar or two

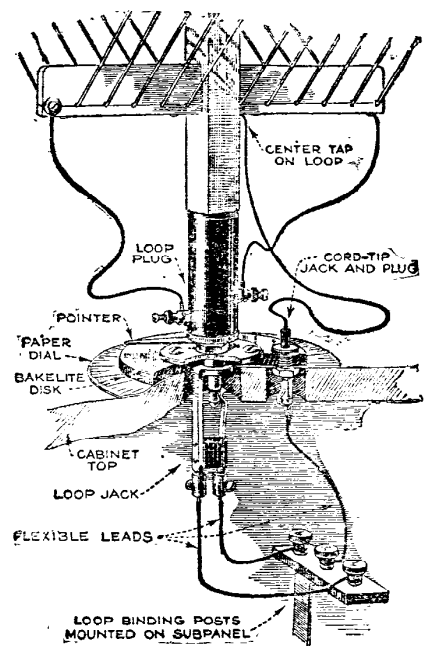

Details of the mounting of the loop on the top of the cabinet, showing the connections to the binding posts.

No. 6-32 machine screws to support the dry cell and also make the positive and negative connections; a small brass nut is soldered to the zinc shell at the base of the cell, holding the cell in place by means of the bus bar. The positive contact is made at the other end of the cell by countersinking a very small hole in the brass positive terminal just deep enough to allow the bus bar or screw to support this end of the cell and make

the second shield; this is exactly like the preceding one, and is mounted in the same manner, except that it is placed far enough back to clear the wave-length condenser. This completes the assembly of the middle or intermediate-frequency section.

The third, and last, section to the right contains the coupling unit mounted on the subpanel, and it will be noted that the soldering lugs on this unit are num-

form a 1¼-in. base, and also bent for ¾ in. at the top. This binding-post assembly is for the purpose of connecting the three flexible leads from the loop jack and cord-tip jack mounted in the top of the cabinet to their respective leads, as shown in the loop-connection drawing. Green silk-covered lampcord is very good for these leads; they should be just long enough to allow the lid of the cabinet to be opened, and can be

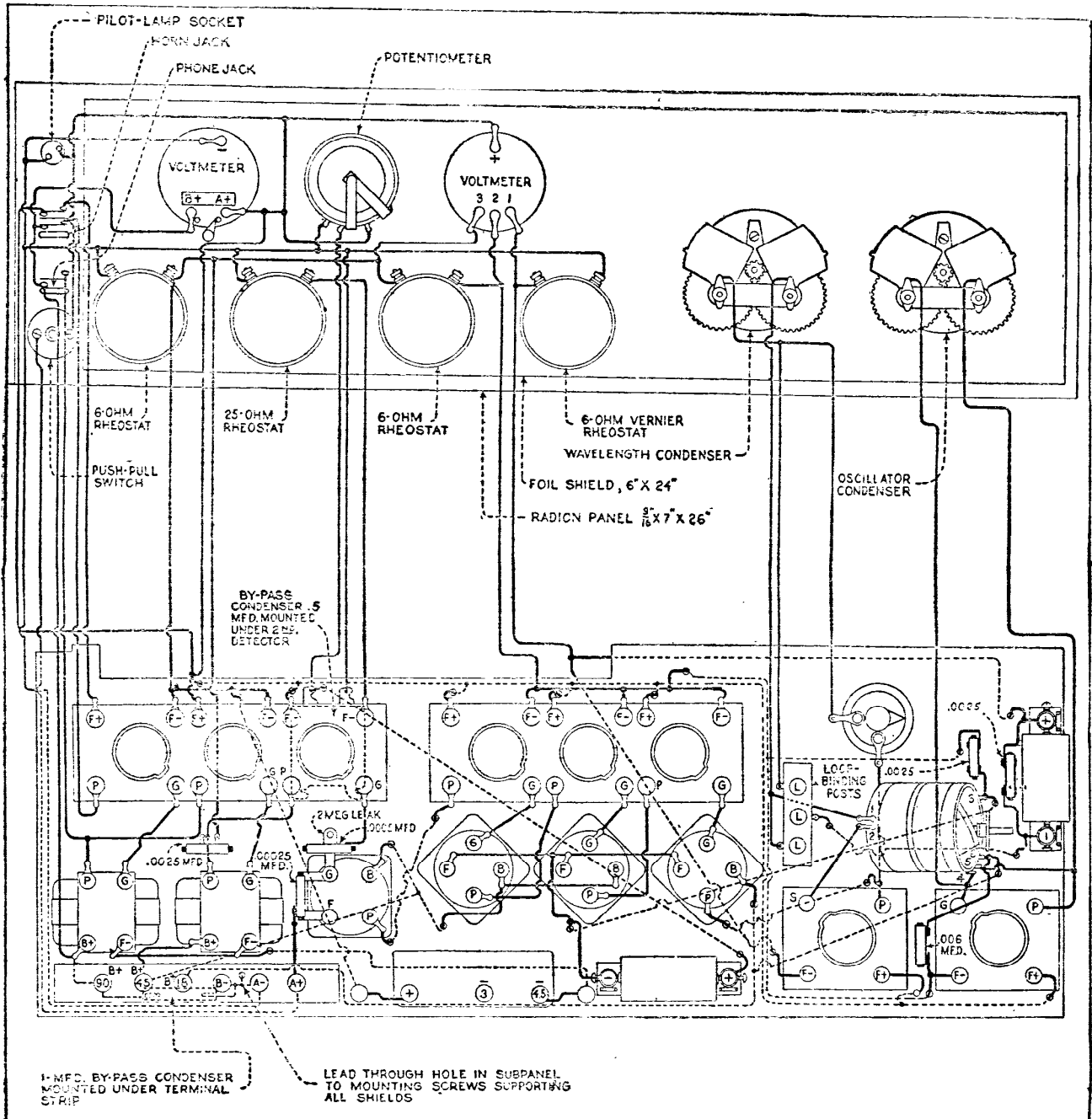

Complete wiring diagram for the Superheterodyne Eight, showing every wire in its proper position. Care should be taken to run every wire exactly as shown, not only to save time in wiring the instrument, but to avoid induction loops. Wires under subpanel are shown dotted, wires above in full lines.

a good contact. A hole is drilled through the center of the bakelite strip for a 1-in. brass machine screw, and a fiber washer is used to support the entire unit above the subpanel. The unit is then mounted in the position indicated. The intermediate-frequency transformers are mounted on the panel in the position shown, to allow the grid and plate leads to be made as short as possible. Next comes

bered as shown in the diagram. Care should be taken when soldering the wire to these small terminals; do not hold the soldering iron to them any longer than sufficient to make a good connection. At the left of the coupling unit is a 3/16 by 5/8 by 2½-in. strip of bakelite, on which is mounted three binding posts. This strip is mounted on a ¼ by ½ by 6-in. bracket bent as shown so as to

bunched through a small screw-eye near the hinge of the cabinet.

The midjet variable condenser is of the table-mounting type and is placed on the subpanel at a point directly between the oscillator condenser and the wave-length condensers on the front panel. When soldering the leads to this condenser, substitute lugs for the copper tabs and solder the wire to the lugs. At

the right of the coupling unit is another of the 1½-volt batteries; this is mounted in the same manner as the 1½-volt C-battery previously described. There is a .0025 mfd. fixed condenser across this battery; this condenser is mounted on the battery unit with bus bar looped under the double binding posts.

At the rear of the subpanel in this section are the sockets for the first detector tube and the oscillator tube; these are of the single type and are mounted on the subpanel with brass machine screws, 1¼ in. long. The oscillator socket is mounted at the extreme right of the subpanel and the first detector socket at the left of the oscillator. This detector tube is of the C-300 or UV-200 soft type; all the other tubes used in the instrument are of the UV-201A or C-301A type. This completes the assembly of the oscillator and first detector section.

Complete all the wiring possible on the subpanel before attaching the front panel, then screw down the subpanel to the brackets already mounted on the front panel, and complete the wiring. Use tinned-copper bus bar for the entire circuit, and cover with a good grade of black "spaghetti" tubing. The leads from the switch points on the voltmeters can be made with smaller flexible rubber-covered wire if desired.

Keep the negative and positive A-battery leads underneath the subpanel and close together, so as not to form any induction loops in the circuits. This also applies to all other leads. Avoid forming loops; keep all grid and plate leads as short and direct as possible, and do not parallel grid and plate leads. All wiring under the subpanel is run direct from point to point. See that the machine screws that go through the subpanel do not touch the wood bottom of the cabinet. The brass brackets elevate the subpanel ¼ in. above the cabinet base, and this allows plenty of room for all screws and wiring to clear the cabinet base. The instrument is now completed and ready to place in the cabinet.

Prepare the lid of the cabinet for mounting the loop jack by drilling a ¾-in. hole through the lid at a point just back of the center, then cut a disk of 3/16 in. bakelite, 3 in. in diameter, for mounting the loop jack; drill this for the oval-head nickel-plated wood screws as shown in the diagram, and also drill a hole at the back of the center in this disk to mount a phone-tip jack for the center tap on the loop. This hole must be drilled so that the cord-tip jack clears the loop-jack flange. Drill another ¾-in. hole through the lid to clear the cord-tip jack. When the loop jack is mounted, no metal should come in contact with the lid. If the reader desires to log the loop there are extra paper-dial charts furnished with the oscillator and wave-length condensers, and one of these dials can be fastened under the bakelite disk that forms the mounting for the loop jack. A disk of celluloid covers the dial and prevents soiling, and at the same

time tends to hold the paper dial flat on the cabinet; the loop aerial can then be rotated and logged. When making the station log, enter the call letters of the station, then the wave length, then the reading on the oscillator condenser, next the reading on the wave-length condenser, and last the position of the loop. The loop is directional and helps materially in cutting out interference. To mount the loop on the loop-jack plug, cut off 1 in. of the fiber shell of the plug and make a wooden plug, 11/16 in. in diameter and long enough to come flush with the top of the loop plug when driven into the latter; then drill a hole through it from end to end to take a 5/16 in. brass dowel pin, 2¾ in. long, which is fitted snugly into the wooden plug and the latter is then pushed into the loop plug. This will then allow about 2 in. of the brass pin to stick up above the top of the loop plug, and as the end of the loop is already drilled to take a pin of this size all that is necessary is to place the loop on the pin and push the wooden plug into the loop jack. For those who would rather not mount their loop on the lid of the cabinet, but prefer to have the loop separate, a mounting base comes with the loop and this is provided with three double binding posts to take the three loop leads. If this is used, the three leads from the binding posts mounted on the subpanel must be brought out through holes drilled in the rear of the cabinet. This completes the loop installation. If desired, a pointer taken from an old rheostat can be soldered to the bottom of the loop-jack plug to work over the paper dial on the cabinet top. This will assist in logging the loop.

Remove the loop, and drill holes through the rear of the cabinet in line with the binding posts for the A and B batteries. Small hard-rubber bushings, such as are used in the bases of electric table lamps, are shellacked into the holes. These are not essential, but add much to the appearance of the cabinet. Use flexible rubber-covered fixture wire for connecting the A and B batteries to the binding posts. The A-battery consists of a 6-volt 80-amp.-hr. storage battery, and the B-battery of either four 22½-volt heavy-duty B-battery units, or two 45-volt units. These are connected in series and tapped off at the first 18-volt positive tap for the plate of the first detector tube and the plate of the oscillator tube; this will be seen by referring to the wiring diagram. The 45-volt positive B-battery tap is for the plate of the second detector tube and the plates of the three intermediate-frequency amplifying tubes. The 90-volt positive tap is for the plates of the two audio frequency amplifying tubes. The instrument is then ready for the tubes.

Take one tube and place it successively in each socket, after pushing in the push-pull filament switch and turning up the rheostats; this will show if there is any error in the filament wiring and eliminates the possibility of burning out all eight tubes. If the tube lights correctly, all the tubes can now be placed in their sockets, being careful to put the C-300 or UV-200 detector tube in the first-detector socket. Set the rotor of the coupling unit at the loosest coupling; see the picture for the approximate position. We are now ready to adjust the instrument under operating conditions.

Take the plug off the end of the loop and place the loop on the extra base that comes with it; take three flexible leads from the loop binding posts in the instrument out to the loop. This will permit the cabinet lid to be raised so that the midget variable condenser and the rotor of the coupling unit can be adjusted for best results under operating conditions. When these have once been set for maximum clarity and volume there will only be two variable adjustments to make in tuning; these are made with the oscillator condenser and the wave-length condenser, and, of course, the position of the loop in regard to the location of the station being received. The rotor of the coupling unit and the midget variable condenser will only require the first adjustment and need not be touched again.

To pick up a broadcasting station:

1. Set the potentiometer about one-quarter of the way up from the lower-left side.

2. Turn up the four rheostats gradually, keeping all four pointers at approximately the same position, and continue until you can hear a soft hum from the tubes.

3. Set the wave-length condenser at any point, say 30°.

4. Rotate the dial of the oscillator condenser 10 to 15° on each side of this mark, moving it slowly and listening for a sound.

5. If a click or whistle, indicating the presence of waves from a station, is heard, but no words or music can be brought in, turn up the third rheostat from the right-hand end, marked oscillator and intermediate-frequency, and also turn up the first rheostat at the extreme right-hand end of the panel, marked audio.

6. When the point is found at which the broadcast comes in the strongest, it may be that the volume is still insufficient. Then turn up the left-hand rheostat, marked first detector, until the volume is sufficient. If a whistle is heard, turn up the audio rheostat until the whistle is gone.

7. If nothing is picked up at the first setting of the condensers move the wave-length condenser up to 10°, and again rotate the dial of the oscillator condenser from 10 to 15° on either side of the corresponding mark. Continue this process over the entire range of the dial.

8. If nothing is heard when the two dials have been moved over the whole range it may be that the oscillator tube is not oscillating. Turning up the two rheostats as described in No. 5 should remedy the trouble. Another way of determining whether the oscillator tube is oscillating is to touch its grid terminal with the finger. If it is oscillating, a click will be heard when the terminal is touched and again when the finger is removed.

If the instrument has been built according to the construction details outlined in this article one will not have long to wait for a station. Rotate the loop from time to time, as this will often enable stations to be picked up that otherwise may be unheard, as the loop is directional. After the instrument has been checked and properly adjusted for maximum results, take off the temporary loop leads and replace the loop plug on the loop. Close the cabinet and push the plug into the loop jack, and plug the center loop lead into the phone-tip jack. See that the loop plug makes proper connection in the jack; if it does not, the wave-length condenser will have no tuning value and it will be noticed at once. If the loop plug goes too far down in the jack, use washers between plug and jack.

Best's 45,000-Cycle Superheterodyne

By G. M. BEST

The features of this set include its use of dry battery tubes and "C" batteries to minimize current consumption, the use of but two operating controls or station selectors, the doing away with loss-causing stabilizers, and the employment of 45,000 cycles as the intermediate frequency. Furthermore, it provides a simple and effective means for volume control. The directions for construction are unusually complete and thoroughly dependable.

THE Superheterodyne circuit is universally recognized as the closest approximation to perfection in radio receivers yet developed commercially. It has extreme selectivity and sensitiveness combined with simplicity of operation.

But, unlike many forms of detector and audio-frequency circuits which give stable operation and good quality of reproduction, the Superheterodyne requires careful attention to engineering details in the selection of parts and in the circuit layout. These features of design have been so perfected in the set here described that the amateur constructor can be assured of a most satisfactory receiver by following the instructions given. They are based upon several years of experimenting and on the construction of a number of sets that are giving at least as good results as any on the market.

While this set can be made without any greater understanding of the theory of the Superheterodyne than is briefly brought out in this constructional article, the reader is advised to study the theory so as to better understand the operation of the set. Articles published in this book clearly outline and explain the principles involved.

Great sensitiveness, or range, of a receiver is dependent upon the use of radio-frequency amplification. At relatively long wave-lengths this is comparatively simple, but at the short broadcast wave lengths there is a tendency to oscillate due to internal capacity and circuit coupling. To overcome this tendency most radio frequency circuits use a "stabilizer" which has very properly been called a "losser." Such a stabilizer takes either the form of a resistance in the tuning circuit, introducing a loss to overcome oscillation and thereby decreasing the signal strength as well as broadening the tuning, or a potentiometer to apply a positive voltage to the grid of the radio-frequency amplifier tubes. This not only increases the drain on the plate battery but also cuts down the gain from the tubes and results in distortion. The stabilizer not only introduces an extra unnecessary control but is a makeshift to compensate for errors in engineering design. Some of the popular descriptions of Superheterodyne circuits specify a stabilizer, with all its disadvantages, to compensate for errors in layout, in transformer design, or in the selection of

the intermediate frequency. This loss in efficiency is then partially offset by the use of high mutual conductance tubes such as C-301A or UV-201A. In multi-tube sets the dry battery tube C-299 or UV-199 gives more than sufficient amplification when operated at full efficiency.

The Superheterodyne circuit overcomes the difficulties of radio-frequency amplification at broadcast wave-lengths by heterodyning or transferring the voice modulation from the incoming carrier wave to a new carrier wave of a frequency at which the effect of inter-electrode and wiring capacities disappears. The proper selection of this intermediate frequency is important. A careful analysis shows 45,000 cycles to be the best frequency. If a frequency higher than 50,000 to 60,000 is selected, internal capacity effects will tend to shunt the energy being amplified, reducing the overall gain as well as introducing instability. If the intermediate frequency is below 40,000 cycles the two settings on the oscillator condenser scale will be too close together, especially at the lower wave-lengths, and poor musical quality may result.

In the Superheterodyne all radio frequency amplification is obtained at a fixed frequency, irrespective of the incoming wave-length. This eliminates all controls on the radio frequency amplifiers and thus reduces the actual number of controls to two.

Maximum amplification, however, is obtained only when the intermediate frequency transformers are designed to operate at the selected frequency and their in-put impedances match the output impedance of the tube. This design is incorporated in the transformers specified or can be duplicated by following the directions for winding as given in this article.

Another advantage of this set is that it employs dry battery tubes, C-299 or UV-199, thus being extremely economical in current consumption, the filament current being less than $\frac{1}{4}$ ampere for the eight tubes. Due to the use of three C batteries the plate current drain on the B batteries is only 10 to 12 milliamperes.

Circuit Analysis

Fig. 3 shows the circuit. It is readily analyzed in four sections: (1) The local oscillator for generating the heterodyne

frequency and the preliminary detector in which the incoming wave and the locally generated oscillations are mixed (tubes marked OSC and 1st Det. with associated circuits); (2) three stages of 45,000 cycle intermediate frequency amplification (tubes IF1, IF2, IF3 and associated transformers, T1, T2, T3, T4); (3) the final detector (marked 2nd Det.); and (4) two stages of audio frequency amplification (tubes AF1 and AF2 and associated transformers T5, T6).

The three stages of intermediate frequency amplification require four 45,000 cycle transformers, the last stage, T4, being of the tuned type, T1, T2 and T3 are iron core transformers, whereas, T4, with air core, has a secondary circuit turned to 45,000 cycles by the fixed condenser, C7, of .00025 mfd. capacity. The value of this condenser must be fairly accurate so that the frequency of transformer T4 will closely approximate 45,000 cycles, the frequency at which transformers T1, T2, T3 are designed to operate with maximum gain.

Two stages of audio frequency amplification, transformers T5 and T6, are connected in accordance with standard practice.

Instead of the conventional grid-condenser-grid-leak method, detection in the preliminary detector is obtained by biasing the grid to operate at the bend in the plate current-grid voltage characteristic. The negative voltage of 4½ is fed through the loop and not only reduces the plate current almost to zero, but by increasing the impedance of the tube increases the selectivity of the loop circuit.

The final detector tube uses the customary grid condenser C8 and grid leak for obtaining detector action. Note particularly that this grid condenser has a capacity of .0005 mfd. due to the comparatively low frequency of 45,000 cycles at which it operates. The value of the grid leak, although not critical, should be between 2 and 3 megohms.

L1, L2, L3 is the oscillator coil system, Remler Type 620 being used in the sets made by the author. For those desiring to construct their own coils the following dimensions are given: Oscillator coil 70 turns of No. 26 D. C. C. wire in two sections of 35 turns each, wound on a 2¼-in. tube. Grid coil, 20 turns of No. 26 D. C. C. wire wound on a 1½-in. tube and arranged to rotate within the oscillator coil in a manner

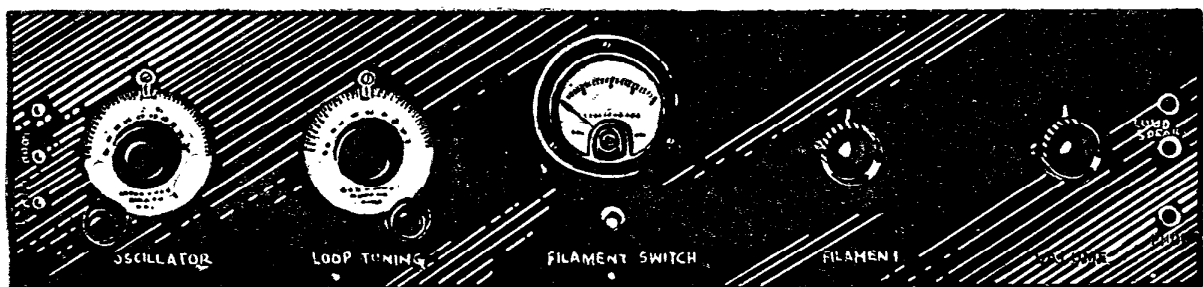

Fig. 1. Superheterodyne Panel Front.

Illustrations by Courtesy of Radio

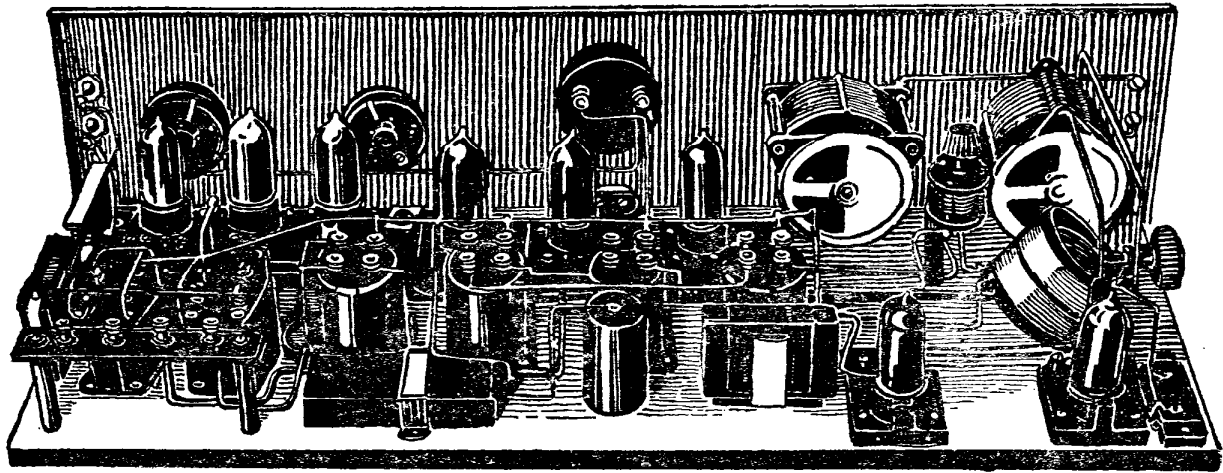

Fig 2. Rear View of Completed Set.

similar to the rotor in a 180-degree variocoupler. Pigtail leads should be used for the rotor connections.

C1 and C2 are variable air condensers for tuning the loop and the heterodyne oscillator respectively.

By-pass condensers for radio frequency currents play a very important part in the successful operation of this circuit. C4 by-passes radio frequency current across the 4½ volt C battery on the 1st detector tube. C5 by-passes the radio frequency currents in the oscillator and three intermediate frequency circuits across the 1½ volt C battery. C6 forms a direct filament return for the high frequency current in the plate circuit of the oscillator tube.

These last two condensers are extremely important as they confine the radio frequency currents from the local oscillator within its own circuit and prevent their flow through batteries or other parts of the circuit where their presence would tend to cause instability.

Condenser C9 shunted across the primary of the first audio frequency transformer by-passes the 45,000 cycle current in the plate circuit of the final detector. Its value is very important and should be .0025 mfd. If its value is too low it will offer a high impedance to the 45,000 cycle currents; if too high it will distort the audio frequency currents.

Condenser C10 is not critical in value but should be at least 1 mfd. It by-passes the alternating current component in the plate circuit of all tubes supplied by the 45 volt section of the B battery.

A plate voltage of 45 is used on all tubes except the two audio frequency amplifiers. On these tubes 90 volts is used.

Note that the negative terminal of the B battery is common to the negative terminal of the A battery instead of to

the positive A battery terminal as is general practice in most radio circuits. This eliminates the danger of filament burnout by the B battery in the case of an accidental short in the variable condensers, the by-pass condensers or other parts of the circuit.

The rheostat R1, 6 ohms resistance, regulates the voltage supply to the filaments of all the tubes. This voltage is indicated by a voltmeter, the use of which is recommended to insure maximum life of the tubes.

The rheostat R2, 6 ohms resistance, is connected into the filament of the first detector and the three intermediate amplifiers and serves as a volume control.

It will be noted that no shielding is shown in the illustration of either the panel or the apparatus. Some shielding may be necessary if the receiver is close to a high power broadcast station. The best material is either sheet copper or tin plate of sufficient thickness to stay in place when tacked to the interior of the cabinet. If the tuning appears broad for the local station it would be well to place a metal partition between the oscillator tube and the intermediate frequency amplifier. This shield should extend from the back of the panel to the rear of the baseboard. In extreme cases it may also be necessary to shield the back of the panel.

The loop circuit differs from the conventional type in that a center tap is employed. This is an application of the Armstrong circuit, by which a sufficient amount of energy is fed back from the first detector to the loop circuit, through a small condenser C3, ranging in value from 1 to 20 micro micro-farads, so that the loop resistance is considerably lowered, thereby increasing the selectivity

and signal strength. One side of the loop goes to the grid of the 1st detector, and the other side is connected to the plate through the feedback condenser, while the center tap is connected to the filament.

Selection of Parts

In selecting the parts used in the building of this set, consideration was given: first, to parts that would combine to perform most efficiently; second, to parts having the lowest price consistent with good quality; and third, to parts of standard manufacture that are well known and readily available at radio stores.

The accompanying table lists the parts used and recommended by the writer. (See Part List.)

Substitution may be necessary, but the reader is advised to adhere to the above suggestions to prevent unknown factors entering into the construction of the set. This is particularly true of the vacuum tubes, which should be either CX-299 or UX-199.

If any of the parts in the list are not obtainable or if parts of similar design are on hand, substitutions can be made. The panel drillings shown in Fig. 5 and the baseboard layout, Fig. 6, only apply to the exact list of parts given.

The list of parts calls for a Jewell voltmeter and the drilling shown in Fig. 5 is for that instrument, although a Weston is shown in the picture. Any standard voltmeter with range of 0 to 5 volts may be used. Its current consumption should not exceed 10 milli-amperes at 3 volts. Beware of cheap voltmeters.

General Radio condensers have been recommended for the two station selectors C1 and C2. One of the advantages of the Superheterodyne is the permanent calibration of these condenser set-

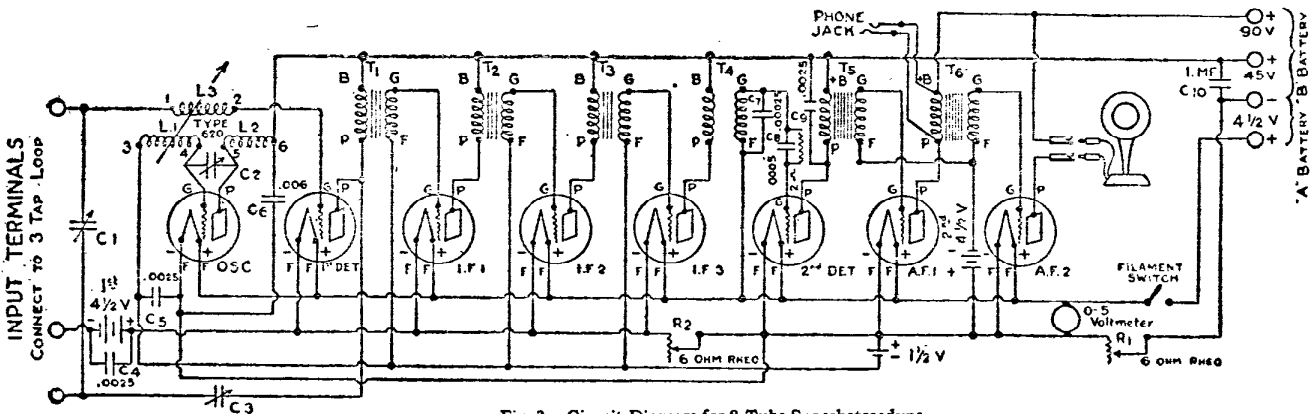

Fig. 3. Circuit Diagram for 8-Tube Superheterodyne.

tings. To insure accuracy the bearing construction must be excellent, pigtail connection should be made from the rotor plates to eliminate possibility of noise due to loose or friction contacts, and some form of geared drive (at least 4 to 1 ratio) to facilitate close tuning. Do not use condensers with vernier plates. The capacity of these condensers should be about .0005 mfd. (approximately 21 plates).

Remler intermediate frequency transformers were used in the original model. Laboratory measurements show these transformers to have a smooth and uniform frequency characteristic between 40,000 and 50,000 cycles. The impedance values throughout this range of frequency are uniform and of the proper value for use with C-299 or U-199 tubes. The iron core construction limits the stray field and permits of close spacing, without shielding (which always introduces a loss) and without circuit instability due to linking of the stray fields between transformers. Air core transformers cannot be used in this set without appreciable changes in the entire layout.

A Remler tuned stage transformer is recommended as it is designed to operate with the intermediate frequency transformer, and is uniform in appearance.

The Stromberg-Carlson audio-frequency transformers shown in the layout are compact in design, have a convenient terminal arrangement, a good voice characteristic and correct impedance values. There are, however, many good standard makes of audio-frequency transformers available, such as the Federal No. 65, Kellogg 3½:1, General Radio, or Amertran. For voice quality do not use a transformer with a turn ratio greater than 3½:1.

The various fixed by-pass condensers should be of standard manufacture to insure capacity values closely agreeing with their rated values.

A picture of the loop is shown in Fig. 4, and all dimensions are given in Fig. 11. It is not necessary that the exact form of loop shown to be used as long as the general dimensions and spacing between turns and the number of turns are complied with. In the operation of the set it is necessary to change the direction of the loop for the reception of different stations. For this reason it will be convenient, although not absolutely necessary, to have a swivel base. The loop is wound with a total of 12 turns of single strand No. 18 silk covered lamp cord.

The Assembly

First decide on the parts to be used, making changes in the panel and baseboard layout to provide for any substitutions. Study Fig. 1, 2, 3, 5 and 6 carefully. Figs. 1 and 2 will give an excellent idea of what is to be accomplished in the mounting and wiring of the set and how it will look when completed. In

SUGGESTED LIST OF PARTS

Number Required	MANUFACTURER TYPE NUMBER	ARTICLE	CIRCUIT DESIGNATION
3	Remler Type 600	Intermediate Frequency Trans-	T ₁ , T ₂ , T ₃
1	Remler Type 610	formers	T ₁ , T ₂ , T ₃
1	Remler Type 620	Tuned Circuit Transformer	T ₁
8	Remler Type 399	Coupling Unit	L ₁ , L ₂ , L ₃
2	(See text)	Sockets	Sockets for Tubes
2	General Radio 247A	A.F. Transformers	T ₁ , T ₂
1	Chelton	Condensers	C ₁ , C ₂
1	Jewell or Weston	Midget Condenser	C ₃
1	Cutler-Hammer	Voltmeter	0-5 V. Voltmeter
2	Federal 18	Radio Switch	Filament Switch
1	Frost No. 133 or Federal	Rheostats	R ₁ , R ₂
1	Federal No. 133	Open Circuit Jack	Phone Jack
1	Dubilier No. 600	1 mf. Fixed Condenser	C ₄
1	Dubilier No. 601	.006 mf. Fixed Condenser	C ₅
1	Dubilier	.0005 mf. Grid Condenser with	C ₆
3	Dubilier	Grid Leak Mounting	C ₇
1	Dubilier	00025 mf. Fixed Condensers	C ₇
1	Radiotron 2-3 Megohm Grid Leak	0025 mf. Fixed Condensers	C ₄ , C ₅ , C ₆
2	Union	Grid Leak	2 Megohms
7	Any Standard Type	Phone Tip Jacks	For Loud Speaker
1	Eveready 950	Binding Posts	For Loop and Battery Terminals
2	Eveready 751	C Battery	1½ V.
1		C Battery	1st—4½ V., 2nd—4½ V.
30 ft.		Bakelite Panel, 26" x 6" x 1/8"	Fig. 5
20 ft.		30 ft. No. 16 or 14 Tinned Copper Wire	
		Spaghetti Tubing	

Material for details of special mountings, Figs. 7, 8, 9 and 10.
Material for Loop—Wood frame and bakelite winding supports
110 ft. No. 18 or 20 Standard Lamp Cord.

the actual construction, the base board and panel assembly can be started in two separate units.

After the panel is drilled two variable condensers C1 and C2, voltmeter, filament switch, two 6-ohm rheostats, jacks and the binding posts may all be mounted. All of the wiring between instruments on the panel may next be run.

The tube sockets, transformers and other apparatus are next mounted on the baseboard in accordance with the layout in Fig. 6. Follow these dimensions closely, because this set has been built in the most compact manner possible without internal shielding; arrangements of the apparatus other than shown may result in instability of the entire circuit. Most of the apparatus is screwed direct to the baseboard.

However, a few special fittings were found necessary for mounting the battery terminals (Fig. 7), condenser C10 (Fig. 8) and two of the C batteries and the Chelton midget condenser C3 (Fig. 9).

It was also found desirable to mount the sockets for the final detector tube and the two audio-frequency amplifiers on a small strip of bakelite, supported at the ends by sponge rubber (see Fig. 10). This eliminates microphonic tube noises and any tendency for the circuit to howl at an audio-frequency when a loud speaker is used. All of the leads run-

ning from these three sockets should be flexible wire.

Fixed condensers C4, C5 and C6 are screwed to the baseboard. Condenser C7 is mounted on the tuned stage transformer with the clips provided with the transformer for that purpose. Condenser C8 has one terminal common with C7 and is therefore supported by the transformer clips. Condenser C9 is soldered to and supported by the wiring and rests on the top of the first audio-frequency transformer.

To facilitate wiring, the lettering on the parts in Fig. 6 agrees with that in the schematic wiring diagram, Fig. 3. For Example, Fig. 3 shows a lead from terminal P of the I. F. transformer T3 direct to the plate P to tube I. F.2. Referring to Fig. 6, a wire is run direct from terminal P to T3 to terminal P of socket 1F2.

Except for the flexible leads mentioned above use No. 14 or 16 tinned copper wire formed to shape and protected with spaghetti tubing. All connections should be carefully soldered or the binding posts thoroughly tightened with a pair of pliers, in case the apparatus is not provided with lugs.

The wiring of the instruments on the baseboard may be done in any convenient order. However it would be preferable to wire the filament circuit first,

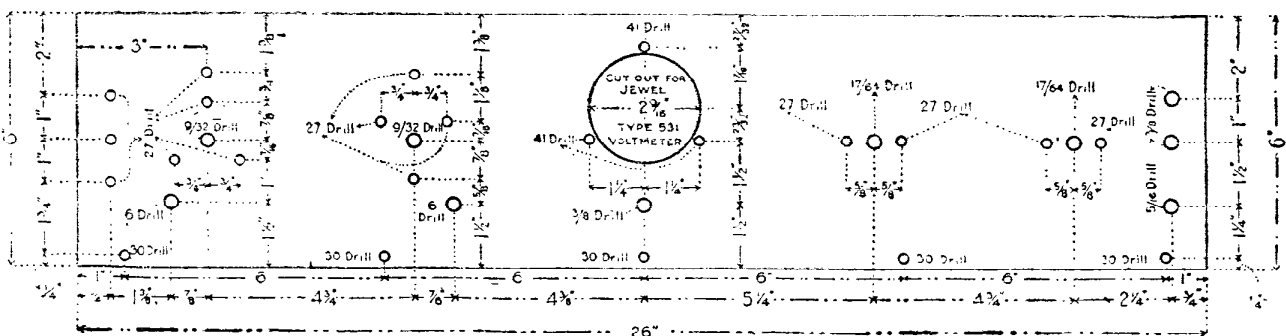

Fig. 5. Panel Drillings

with the exception of the connections that run to the instruments on the panel. Then wire the complete oscillator circuit and the first detector circuit, omitting wires running to terminals on the panel. Proceed next with the entire intermediate frequency amplifier circuit, final detector and the audio-frequency ampli-

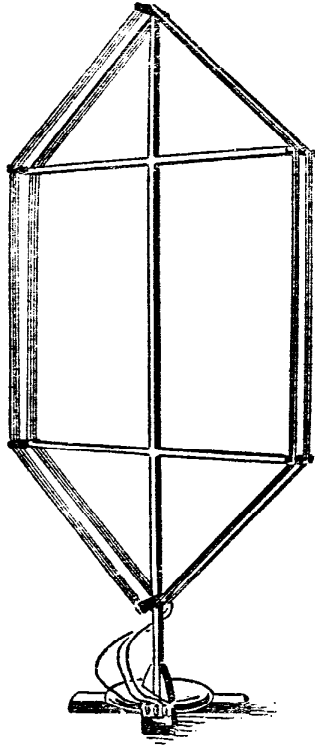

Fig. 4. Three-Tap Loop.

fier unit, in the sequence mentioned. When the baseboard wiring is completed the bakelite panel can be screwed to the front edge of the board and the wiring between the instruments on the panel and those on the baseboard completed.

Preparing the Set for Operation

With all wiring completed it is advisable to finally check your work with the wiring diagram. Do not insert the tubes until the following instructions have been carried out:

Connect the loop to the three binding posts on the left end of the panel. The center tap of the loop must be connected to the center binding post. One of the outside loop terminals should be con-

nected to the top binding post and the other to the lower binding post. These two connections may be reversed without affecting the operation of the set.

The B battery unit should consist of two 767 Eveready 45 volt batteries connected in series. Connect the negative terminal of this unit to the binding post marked - AB Fig. 6, the positive 90 volt terminal to the binding post marked 90B and the 45 volt terminal where the two batteries are connected in series to the binding post marked +45B.

After this has been done and before the A battery has been connected, plug in the phones and the loud speaker in the jacks provided. Close the filament switch, located on the panel under the voltmeter, and turn the rheostat up a few degrees. Any deflection of the voltmeter indicates an error in the wiring of the filament or B battery circuit. If such an error exists the trouble must be located and eliminated at once. If the voltmeter is not deflected the A battery can next be connected to the terminals marked +4 1/2 A and -AB, Fig. 6.

Again turn on the filament switch and note the voltmeter reading, which should be 4 1/2 volts. If this reading is obtained the wiring of the A and B battery circuit is correct. If the meter should fail to read it is because the filament circuit is open. If the needle is deflected to the end of the scale, the B battery voltage is shorted through the filament circuit.

The tubes can now be inserted. First see that the filament rheostat is turned to the off position and that the volume control rheostat on the right hand end of the panel is turned clear to the right; also that the filament circuit switch is

open and that the terminals of all the tubes and the contacts in the sockets are clean. Close the filament switch and

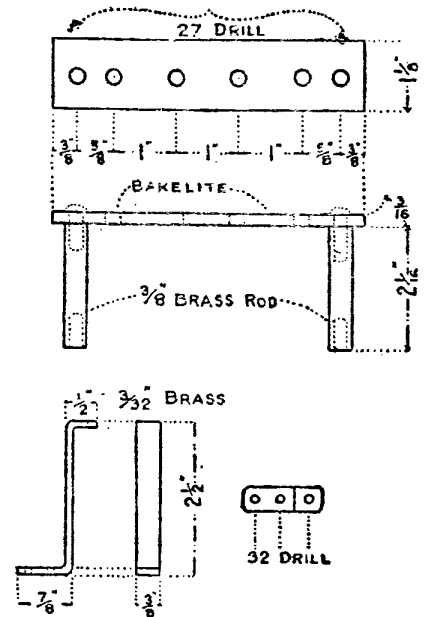

Fig. 7. Special Mounting for Battery Terminals

turn the filament rheostat until the voltmeter indicates a filament potential of exactly 3 volts. This value should never

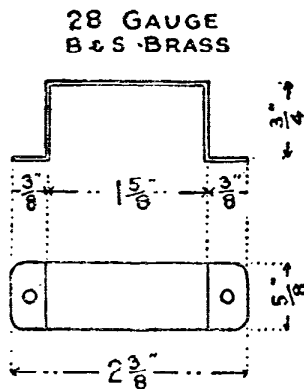

Fig. 8. Mounting for C₁₀

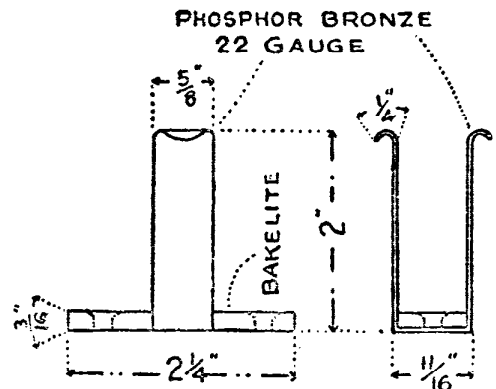

Fig. 9. Mounting for Midget Condenser and "C" Battery

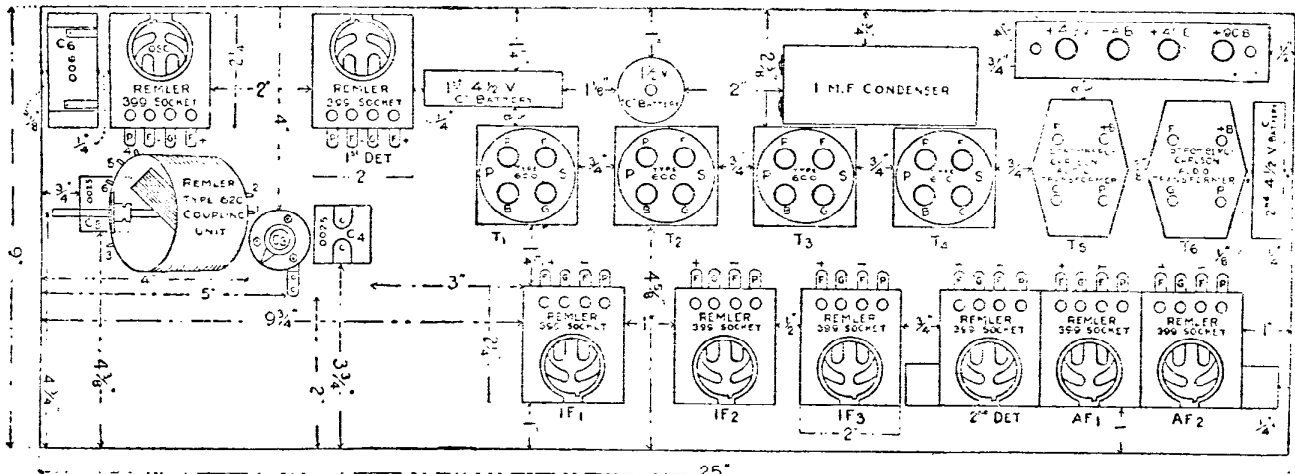

Fig. 6. Baseboard Layout

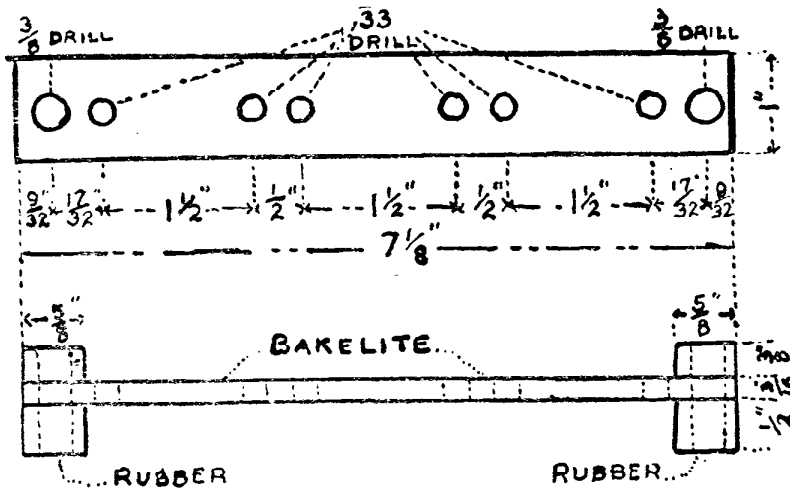

Fig. 10. Mounting for Detector and A. F. Amplifier Tubes.

be exceeded, as doing so will shorten the life of the tubes and may cause permanent injury to their filaments.

Adjusting and Operating the Set

The set is now ready for an actual operating test. This should be done at a time when it is known that a broadcasting station of medium or high power is operating within a range of 100 miles. In normal operation there are only two variables to adjust, condensers C1 and C2. Volume control R2 cannot be classified as a variable. The rotor of the coupling unit and value of condenser C3 require initial adjustment but, once set, will probably not need further attention. Set condenser C3 at the position for minimum capacity; that is, so stator and rotor plates are not interspaced. Its final adjustment follows later.

Set the rotor coil of the coupling unit half way between the maximum and minimum coupling positions.

To locate a broadcasting station with the tuning controls set the loop condenser, which is the one at the extreme left end of the panel, to the 5-degree position, then slowly turn the oscillator condenser from zero to 15 degrees. If no signal is intercepted change the loop condenser setting to 10 degrees and again slowly turn the oscillator condenser from 0 to 20 degrees. This process should be continued until a station is intercepted, changing the setting of the loop condenser about 5 degrees each time and slowly turning the oscillator condenser from a point at least 10 degrees below the loop setting to 10 degrees above the loop setting. When tuning distant stations the same procedure applies, only it will be necessary to make loop settings every two degrees or even every degree if the signal strength of the station to be received is weak.

When a station is picked up it will be noted that it can be received at two settings of the oscillator condenser, the lowest one on the dial being the adjustment of the oscillator that gives a frequency 45,000 cycles higher than the frequency of the incoming wave. The setting highest on the dial is for the fre-

quency of the oscillator that is 45,000 cycles below the frequency of the incoming wave. Signals should be received with about the same intensity at either of these settings, but sometimes under conditions of interference from other broadcasting stations or spark transmitters it will often be found that one gives better results and less interference than the other.

If the station received is within a radius of four or five hundred miles the amplification obtained in the intermediate frequency amplifier will probably be so great that the audio-frequency amplifier tubes will be overloaded. This undesirable condition can be corrected by turning the volume control rheostat to the left until the volume is sufficiently reduced and distortion eliminated.

After one station has been received it will be fairly easy to pick up additional stations. Each time a station is tuned in its location on both the loop condenser and the oscillator condenser should be noted. This is important not only for tuning in the same station at another time but to facilitate the location of stations whose wave-lengths are known to be slightly above or below the station for which settings were recorded.

When a station at least 1,000 miles distant has been tuned in the rotor of the coupling unit should be adjusted to as near the minimum coupling position as is possible without causing a decrease in signal strength. Once this adjustment has been made the rotor may be locked in place with the set screw provided for that purpose and need never be changed again throughout the life of the oscillator tube. When a new oscillator tube is inserted in the socket it will be well to readjust the setting of the rotor.

The adjustment of condenser C3 should be made while a station of low wave-length, between 300 and 350 meters if possible and located at a distance of several hundred miles, is being received. Under these conditions increasing the capacity of the condenser will cause a considerable increase in signal strength. This capacity may be increased as far as possible without causing the first de-

terior tube to oscillate or cause distortion of the received signal. When this adjustment is once made it can remain fixed for the reception of all stations on any wave-length.

If, after carefully following these instructions for tuning the circuit, no signals can be received and at a time when it is known that a local broadcasting station is operating, a test should be made to determine whether or not the oscillator tube is oscillating. A good method of doing this is to touch the grid terminal of the oscillator tube socket. If the tube is oscillating a click will be heard in the phones when the finger touches the terminal and again when it is withdrawn. If it is not oscillating a click will only be heard when the terminal is touched and not when the finger is withdrawn. Failure of the tube to oscillate may be due to incorrect wiring of the oscillator circuit; tube terminals may not be making contact with the socket prongs; or to the use of an old tube that is inoperative. Remedies for such conditions are obvious.

The range of reception depends largely upon the power of the broadcasting station. When the operator has become familiar with the tuning of this set little difficulty will be experienced in receiving 500 watt stations up to a distance of 2,000 miles. Under favorable atmospheric conditions the set is capable of reception across the continent.

If an audio-frequency amplifier of at least two stages is available, tubes AF1 and AF2 with transformers T5 and T6 may readily be omitted. This will also eliminate the 90 volt B battery terminal. The terminals from the final detector, shunted by condenser C9, should then be connected direct to a phone jack or other output terminal.

One intermediate frequency stage may be omitted with corresponding loss in amplification by eliminating transformer T3 and tube IF3. This would result, without the audio-frequency amplifier, in a 5 tube set of remarkable capabilities.

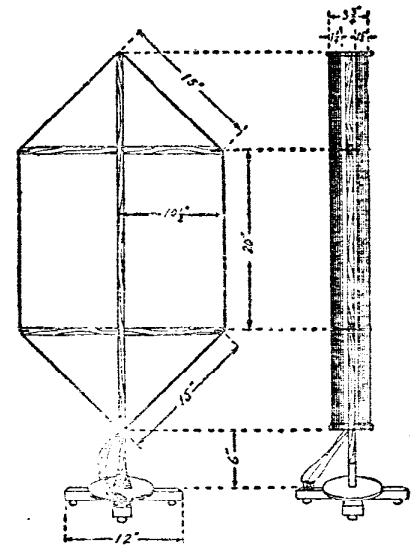

Fig. 11. Loop Dimensions.

The Modified Best Superheterodyne

By GERALD M. BEST

PART I—SHIELDED MODEL

An All-wave, Panel-mounted Set Using Seven Small Tubes and Adapted to an Outdoor Antenna

THE increasing number of broadcast stations operating on wave-lengths below 250 meters together with the greater amateur use of the band from 40 to 100 meters, has created a demand for radio receivers capable of efficiently covering these shorter wave-lengths as well as the higher waves from 250 to 550 meters. In previous models of the 45,000 cycle Superheterodyne having a range from 200 to 580 meters, stations below 250 meters were crowded into a small space at the lower end of the oscillator condenser dial, especially where condensers of the semi-circular type were employed. Consequently the set has been re-designed so as to use different coils for different bands. This involves an improved oscillator system and new apparatus in other parts of the circuit.

In order to include the desirable features of several types of construction, two models employing the same basic circuit will be described, one model being completely shielded, with all the apparatus mounted on the back of the panel, and using dry cell tubes and the other model comprising a baseboard layout, with storage battery tubes similar to the one described in the previous article, so that those who have already constructed that receiver may rearrange their equipment, and with a few additions may incorporate all the advantages of the new design. The shielded model described herein will particularly appeal to the advanced constructor. If the building of the shielded panel appears to be difficult for the novice, it would be advisable for him to construct the baseboard model, which will be described on pages 58 to 62.

From the illustrations, it will be seen that the apparatus is mounted on the

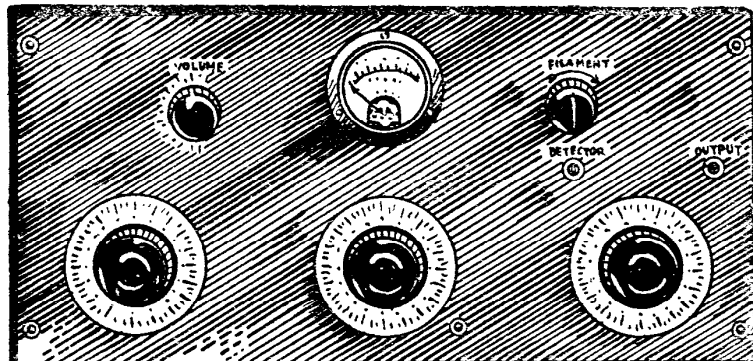

Front Panel View.

back of the panel and on a brass shelf supported by the panel. The shielding is made in one piece by soldering the various parts together, or fastening with machine screws, and is held to the back of the panel by the mounting screws provided for holding the panel apparatus in place.

From the picture of the front panel layout, it is evident that there are three controls for tuning, the receiver being designed to operate with an outdoor antenna. By carefully shielding the antenna tuned circuit, and arranging the coil system so that critical coupling is obtained between the antenna and secondary tuned circuits, a degree of selectivity comparable favorably with an ordinary loop antenna is obtained, with greater signal strength and no radiation.

Fig. 1 shows the schematic circuit diagram, on which are plainly marked the

values of the various pieces of apparatus. The vacuum tubes are arranged in the following order: heterodyne oscillator, frequency changer (commonly called the 1st detector), three stages of intermediate frequency amplification, detector and one stage of transformer coupled audio frequency amplification. Seven dry cell tubes of the C-299 or UV-199 variety are required, the tubes being controlled by a filament rheostat, R1 of 6 ohm resistance, mounted at the upper right-hand end of the panel. A voltmeter having a scale of 0-5 volts is provided for adjustment to the proper filament voltage. Storage battery tubes should not be used in this model due to almost insuperable trouble from coupling in the amplifier.

Beginning at the antenna end of the receiver, the antenna system consists of a variable condenser C1 of .0005 mfd.

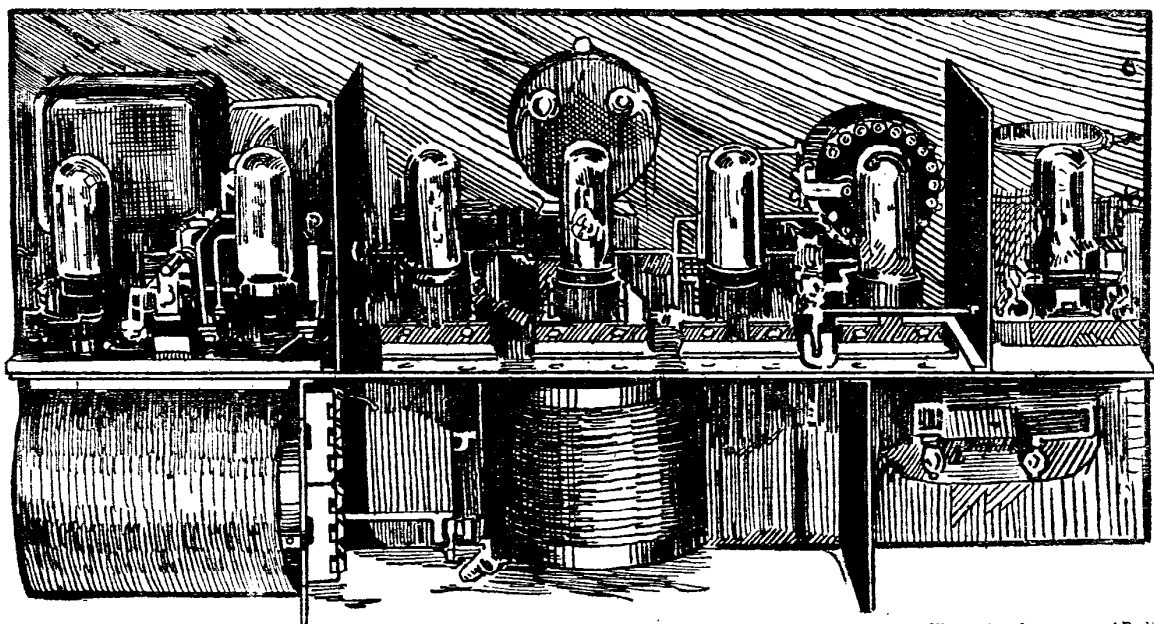

Rear View Showing Arrangement of Apparatus on Shelf.

Illustrations by courtesy of Radio

capacity, a primary loading coil, and a coupling coil, placed in series between the antenna and ground terminals. The loading coil is wound on a 4-in. fibre tube, and consists of 94 turns of No. 20 bare copper wire, wound 20 turns to the inch in a groove cut in the tubing. This groove is best made by placing the tubing in a lathe and cutting with a sharp pointed Armstrong tool, using the screw cutting attachment of the lathe.

The coupling coil is the rotor of a conventional type of 180 degree variocoupler, on which are wound 8 turns of No. 20 bare wire, with the same spacing as for the loading coil. The latter is provided with a tap at the 15th turn, for use on the short waves. The secondary winding consists of 46 turns of No. 20 bare copper wire wound on the stator of the variocoupler, which is of 4 in. diameter and is tuned by condenser C2, .0005 mfd. Taps are taken off at the 10th and 22nd turns, to provide adjustment for the short waves. These taps are brought up through holes in the brass shelf to a set of terminals so that the wave-length range of the secondary can be easily changed. In the experimental set, a coil mounting such as was used for the oscillator coil was mounted on the back of the shelf, and a flexible cord with a phone cord tip was employed for changing taps. The tap for the load coil was brought out in the same manner, since it was not desirable to have switches mounted on the panel for changing the connections.

From the picture of the under side of the shelf it can be seen that brass partitions are mounted so that the antenna series condenser and load coil are in one compartment, the secondary coil and condenser in another, and at the opposite end of the panel the oscillator condenser is provided with a compartment of its own. These partitions are necessary in order to prevent coupling between the antenna load coil and the secondary coil, and also any possible coupling between the oscillator circuit and the antenna system. Energy from the antenna tuned circuit is fed into the frequency changer by means of C3, a grid condenser of .00005 mfd., shunted by a 3 megohm grid leak. R2 the grid return being to the negative end of the filament in order that the entire negative filament circuit of the receiver may be grounded.

The oscillator system consists of an inductance coil having two windings of equal size wound on a 2 3/4 in. Bakelite tube, a variable condenser C4 of .0005 mfd. capacity in series with a fixed mica condenser C5 having a capacity of .006 mfd., a grid leak, R3 of approximately .1 megohm, and a mica condenser C6 of .006 mfd. The oscillator coil is arranged so that it can be removed from the set and coils of other inductance inserted in the same mounting. Four plugs are mounted on the bottom of the coil in such a manner that they will fit into a four plug mounting placed on the metal shelf. This coil can be seen in the picture of the back panel layout, at the extreme right-hand end. The oscillator tube, grid leak and mica condenser C6 are mounted to the rear of the oscillator coil, and the by-pass condenser C11 is placed underneath the shelf, a brass partition shielding the intermediate amplifier from the oscillator coil.

The method of feeding oscillator energy into the frequency changer is similar to that described in another article in this book, the grids of the oscillator and frequency changer tubes being connected together by means of a .1 megohm resistance, condenser C6 being provided to prevent the grid of the frequency changer from becoming negative with respect to its filament and being large

enough to have no effect in the circuit. If the condenser were omitted, the C potential provided for the oscillator grid would be effective on the grid of the frequency changer and would force it to operate on an inefficient point of its detector characteristic curve. If .1 megohm admits too much energy to the frequency changer, a grid leak of higher resistance should be used, the maximum being about .5 megohms.

The grid coupling coil used in former Superheterodynes is abandoned and permits the substitution of different oscillator coils without the complicated connections required when a grid coil was used. The set radiates practically no energy into the antenna, due to the fact that the oscillator is well shielded, and high frequency currents generated by it must first pass through a .1 megohm resistance, then through the 50 micro-microfarad grid condenser in shunt with the 3 megohm leak, and through the very selective tuned circuit. As the output taken from the grid of the oscillator tube is very small, it is obvious that radiation would be negligible.

The intermediate amplifier and frequency changer tubes are mounted in the center compartment, with the volume control rheostat R4, intermediate frequency transformers and voltmeter. It is absolutely necessary to use intermediate transformers having shielded cases, such as the Jefferson No. 150, as unshielded coils will introduce complications which will be very difficult to remedy. The transformers are mounted be-

on its center and bringing out the two ends to some form of tapped switch, such as the Carter inductance switch. No. 36 or No. 38 double silk resistance wire, or copper wire smaller than No. 40, such as is used for the coils in headphones, can be used to wind the resistances below 5000 ohms. The 12,000 ohm resistance can be a standard lavite resistance, and the 6000 ohm resistance can be made by placing two 12,000 ohm lavites in parallel.

The detector and audio amplifier are mounted in a separate compartment, but it has been found since the picture was taken that the partition between the intermediate amplifier and the detector was unnecessary and may be omitted. The tuned transformer was home-made and is tuned by means of condenser C8, a fixed mica condenser of .0075 mfd. shunted across the primary winding. Any good filter transformer suitable for use with the particular intermediate frequency transformers selected will be satisfactory.

The battery terminals are mounted on the partition between the antenna loading coil and the coupler, but could be mounted on the back of the panel above the audio transformer if desired. By-pass condenser C7 is mounted underneath the shelf in the secondary condenser compartment, the additional condenser shown in the illustration being C12, in shunt across the 45 volt B battery line. C9 is a grid condenser of .00025 mfd., R5 a 3 megohm gridleak and C10 is a by-pass condenser of .002 mfd.

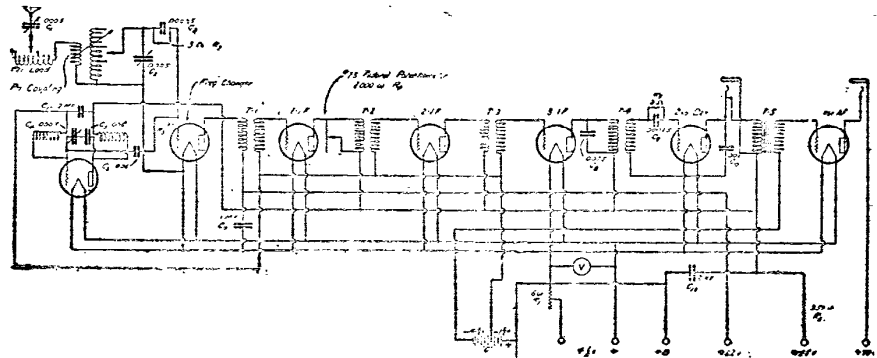

Fig. 1. Circuit Diagram.

tween the panel and the tube sockets, so that the wiring will be as short as possible.

The volume control may be either a set of non-inductive resistances connected to an inductance switch, as is shown in the picture, or a high resistance potentiometer wound to at least 2000 ohms. The use of the latter presents the easiest method of volume control and the least expensive to install. Due to the fact that with the 2000 ohm potentiometer set at maximum resistance, the total amplification will still be below normal, one end of the potentiometer winding should be cut at the point where it is connected to the binding post terminal, so that when the potentiometer knob is set at the extreme clockwise position, the potentiometer will be open circuited.

For those who wish to construct their own potentiometer, the following values of fixed resistances will enable the assembling of a 15-step resistance giving approximately the same change in volume for each step: 12,000, 6000, 2600, 1900, 1120, 680, 420, 270, 170, 108, 68, 24, 27, 17 and 11 ohms. As such resistances cannot be purchased ready made, they should be wound by hand, by measuring the wire off in lengths according to its resistance, doubling the wire back

shunted across both the primary of the audio transformer and the B battery, providing a short path for the high frequency from the plate to the filament in the detector tube.

Jacks are provided for the detector and audio amplifier, it being necessary to insulate the jacks from the metal shield on the back of the panel in order that no short circuit between the positive B battery and the shield be incurred. Three B battery voltages are employed, 22, 45 and 90 volts, the negative end of the B battery being connected to the negative end of the filament circuit, between the vacuum tubes and the filament rheostat.

Protective resistance R6, 350 ohms is installed to prevent burning out the tubes due to short circuits in the 45 volt lead and condenser C12 is a by-pass around this resistance. Instead of including a second audio amplifier tube in the set, a separate power amplifier should be used, operated either from the 110 volt power line, or from a set of batteries. The Western Electric 25-A amplifier was used with the set illustrated.

For those who wish to operate a loud speaker from the Superheterodyne without the use of the power amplifier, an audio frequency transformer having a 6 to 1 turns ratio should be installed, selecting a transformer which has a good

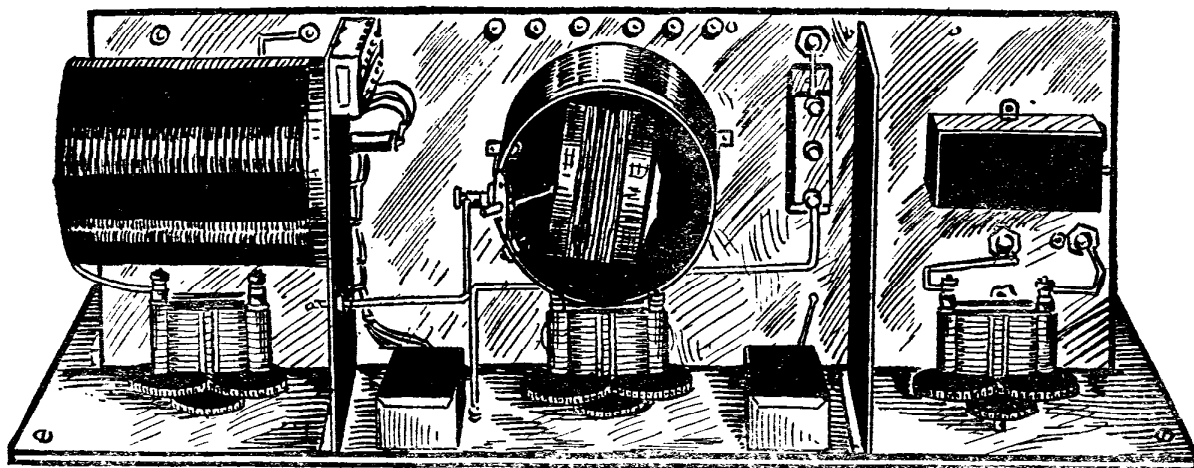

View of Antenna Tuning Equipment on Under Side of Shelf

low frequency characteristic. In Fig. 5 is shown the circuit of a single stage amplifier using a C-301-A tube, the filament being lighted from alternating current, by means of a small bell ringing transformer, so that the amplifier may be used as an adjunct to the main set.

Description of Parts
The accompanying list of parts includes those which were used in the construction of the set and others which will be appropriate substitutes, as the use of the particular equipment shown in the pictures is not essential to the

construction of the receiver. No specific recommendations of any of these parts is implied, much of the apparatus being selected because of the ease in obtaining it at the average radio store.

The panel template shown in Fig. 2 is given for the parts actually used and should be modified to meet the dimensions of any alternative parts which are selected in place of those used in the original set. Generally templates are furnished with air condensers or other panel type apparatus, so that it will be a simple matter to change the panel layout to suit the material at hand. With the most expensive material listed, the total cost of the receiver, without batteries or vacuum tubes, will be about \$85.

After the panel is drilled, a piece of 16 gauge or 1/16 in. brass should be cut to the same size as the panel, to provide the back panel shield, holes being cut in the shield exactly as for the panel, except that in case air condensers having non-grounded end plates are used, the holes in the brass shield should be made sufficiently large to clear the metal supports of the condensers. The holes for the phone jacks should be 1/16 in. larger than those drilled through the panel, in order to prevent short circuiting the jacks to the shield, which is grounded.

The shelf is also made of 16 gauge brass, and is 7x19 in. The three partitions required are all the same size, of 16 gauge brass, cut 4 5/8 x 7 1/4 in., so that a flange 3/4 in. wide can be bent at one end and on one side, for mounting to the shelf and back panel shield.

The simplest method of fastening the shelf, partitions and back panel shield into one solid piece, as shown in Fig. 3, is to drill and tap the flanges of the partitions at several points for 6-32 machine screws, so that the partitions are made to act as the supporting medium for the shelf. If a blow torch is handy, the brass can be heated at strategic points and soldered securely in place with a little non-corrosive soldering paste and a liberal application of rosin-core solder. After the shielding is all in one piece, it can be painted with insulating varnish or other non-conducting paint, or sprayed with Duco enamel such as is used in automobile finishing. This will cover up the scratches, spots of solder and other defects which would otherwise detract from the appearance of the set.

The oscillator coils are three in number, all wound on 2 3/4 in. tubing, 2 1/4 in. long. The coil for the wave band from 50 to 150 meters consists of two sections of 8 turns each of No. 22 double silk wire, the turns being spaced at least 1/16 in. apart. For 100 to 300 meters

PARTS FOR THE MODIFIED BEST SUPERHETERODYNE SHIELDED MODEL

No. Required	Part	Circuit Designation	Makes That May Be Used
3	I. F. Transformer	T ₁ , T ₂ , T ₃	General Radio No. 271, Jefferson No-150, Silver 60 KC, Baldwin-Pacific Shielded.
1	Tuned Transformer	T ₄	See Text.
1	Audio Freq. Transf.	T ₅	All-American, Dongan, General Radio, Jefferson, Karas-Harmonik, Pacent, Premier, Rauland Lyric, Stromberg-Carlson, Supertran, Thordarson 2;1.
2	Jack		Carter, Erla, Federal, Frost, Marco, Pacent.
3	Oscillator Coils		General Radio No. 277-A, B and C.
2	Oscillator Coil Mtgs.		General Radio No. 274-B.
1	Rheostat	R ₁	Amsco, Bradleystat, Carter, Federal, Frost, General Instrument, General Radio, Pacent.
3	Variable Condensers	C ₁ , C ₂ , C ₃	Acme, Bremer-Tully, Cardwell, Ensign, General Instrument, General Radio, Marco, National, N. Y. Coil, Phoenix, Remler, Signal, Silver-Marshall, U. S. Tool.
5	Tube Sockets, Flain		Amsco, Benjamin, Erla, Frost, General Radio, Kellogg, Marco, Remler, Silver-Marshall.
5	Tube Sockets, Cushioned		Benjamin, Frost.
1	Voltmeter		Hoyt Model 17, Jewell Pattern 53, Western Model 301.
2	2 mfd. Fixed Cond.	C ₄ , C ₅	Dubilier, Kellogg, N. Y. Coil.
1	1 mfd. Fixed Cond.	C ₇	Dubilier, Electrad, Kellogg, N. Y. Coil, Federal.
1	.0075 mfd. Fixed Cond.	C ₆	Dubilier, Electrad, Federal, Kellogg, N. Y. Coil.
2	.006 mfd. Fixed Cond.	C ₁ , C ₂	Dubilier, Electrad, Federal, Hilco, Kellogg, N. Y. Coil.
1	.002 mfd. Fixed Cond.	C ₃	Dubilier, Electrad, Federal, Hilco, Kellogg, N. Y. Coil.
1	.00025 mfd. Fixed Cond. with G-L mtg.	C ₈	Dubilier, Electrad, Federal, Hilco, Kellogg, N. Y. Coil, XL.
1	.00005 mfd. Fixed Cond.	C ₉	Amplex, Continental, X-L Model G, Chelton.
2	Grid Leak-3 megohm	R ₂ , R ₃	Aerovox, Amsco, Daven, Durham, Electrad, Filko, Freshman, Rogers.
1	Grid Leak-.1 megohm with mounting	R ₄	Aerovox, Amsco, Daven, Durham, Electrad, Filko, Freshman, Rogers.
1	Potentiometer, 2000 ohms	P ₁	Centralab, Federal.
1	Variocoupler		Atwater-Kent, Hilco, Kellogg.
1	Protective Resistance	P ₂	General Radio No. 283, Don Mac Protecto-tube.
7	Binding Posts		Amsco, Eby, General Insulate, General Radio.

the coil should have two sections of 15 turns each and for 200 to 600 meters the coil consists of two sections of 30 turns each. These coils may be obtained already wound and provided with four plugs for connection to the coil mounting, which is fastened to the shelf. If the coils are home-made, phone tips can be used and four phone tip jacks mounted on a small strip of Bakelite for the coil mounting.

The intermediate frequency transformers should be such as to give good amplification at some point between 40 and 50 kilocycles, for tuned transformers having a peak at 45 kilocycles. If transformers operating at frequencies above or below the above limits are used, care must be taken in selecting the tuned transformer so that the latter will match the intermediate transformers at least approximately. The metal cases of the transformers should be grounded to the shield in order to prevent oscillation in the intermediate amplifier.

The tuned transformer used in the experimental layout is home-made, of the following dimensions: Support consists of spool made from a block of wood $2\frac{1}{4}$ in. square and $\frac{7}{8}$ in. thick, a slot $\frac{3}{8}$ in. wide being cut in the center, leaving $\frac{1}{4}$ in. flanges on the sides. A hub of 1 in. provides a base on which is wound 260 turns of No. 30 D. C. C. wire in a haphazard fashion. After placing a layer of insulating paper over the primary, 1500 turns of No. 36 D. S. C. wire is wound over the paper, for the secondary, the ends of the windings being brought out to terminals on the edge of the flanges. The inside winding of the primary should go to the plate of the last intermediate stage and the outside winding of the secondary to the grid of the detector tube.

The primary is tuned by a fixed mica condenser, C8, .0075 mfd. which should preferably be of the guaranteed 5 per cent accuracy type, such as the Dubilier No. 640 Micadon. If this condenser is very much in error, a double hump will be noted for each side band setting of the oscillator condenser, with resultant loss of selectivity. Other tuned transformers can be used in place of the above coil in case it is not desired to construct it, in which case the tuning condenser specified by the manufacturer should be

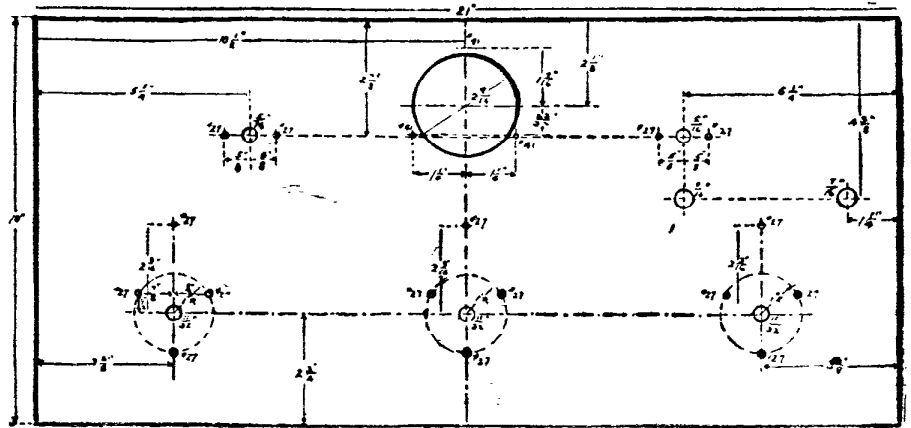

Fig. 2. Drilling Template for Panel.

used. For providing C potential, a No. 751 Eveready Flashlight battery was mounted in the compartment with the audio amplifier, the $1\frac{1}{2}$ volt tap being obtained by scraping away a small amount of the cardboard covering of the battery, on the end towards the positive terminal, thus exposing the zinc case of the last dry cell and permitting a tap to be soldered on the negative of the $1\frac{1}{2}$ volt unit. The entire battery provides $-4\frac{1}{2}$ volts for the audio amplifier, the oscillator and intermediate stages requiring $-1\frac{1}{2}$ volts for best operation. No C battery is used on the frequency changer or detector tube, both employing grid condensers and leaks instead of a high negative grid potential. The reason for abandoning the high negative C potential on the grid of the frequency changer is because the new oscillator system will not permit the use of a C potential on the grid of the frequency changer, and in order to obtain the benefits of being able to change wavelengths at will, the slightly less desirable grid condenser was employed.

Assembly, Wiring and Testing

The three variable condensers, voltmeter, volume control rheostat, filament rheostat and phone jacks should be fastened to the panel, the screws holding the shielding in place without difficulty.

A small fiber insulating washer should be cut out for each jack, to prevent the frame of the jack from touching the metal shield at any point.

The sockets are mounted on small strips of scrap 3/16 in. bakelite, to keep the terminals and socket springs from accidentally touching the shelf. The detector and audio amplifier sockets should be of the cushioned type, as otherwise mechanical vibration of the vacuum tube elements may cause howling in the loud speaker.

The intermediate transformers are fastened to the brass shield on the back of the panel, as close to the shelf as is permissible. The tuned transformer should be mounted an inch or more away from the back panel shield, a small block of wood furnishing a convenient form of mounting. If desired, condenser C8 and the grid condenser C9 with grid leak mounting can be fastened to the sides of the tuned transformer, thus insuring short leads.

The audio transformer is mounted on the back panel shield adjacent to the audio amplifier tube. The battery terminals may be either a binding post strip with 7 binding posts, as conveniently made by several manufacturers, or a set of connecting blocks such as are obtainable at any telephone supply house may be selected. Practically all the ma-

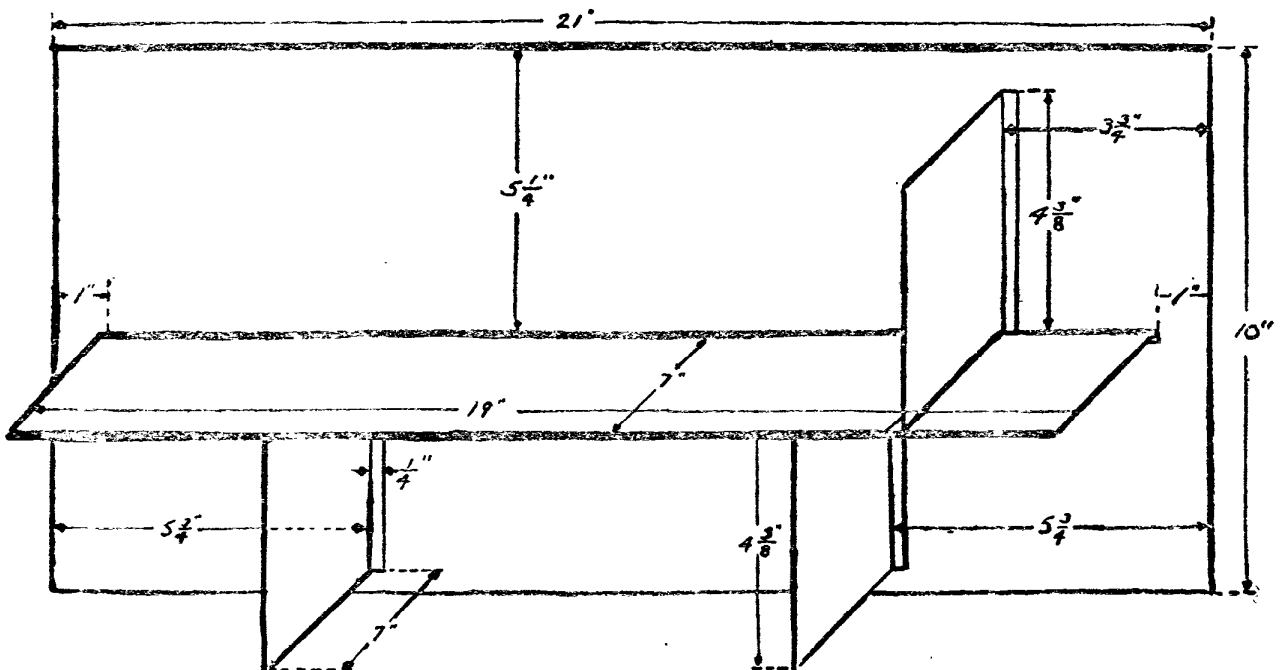

Fig. 3. Assembly of Shield Material.

terial mentioned above must be fastened to the shielding at some point and this will require a No. 33 machine drill and a 6-32 tap, in order to provide the mounting holes for each piece of apparatus.

In wiring the set, the A battery leads, negative B battery and other wires not carrying high frequency currents were run with flexible insulated wire closely bunched together, thus saving space and

distorted. Try substituting a .25 megohm leak in place of the .1 megohm and see if an improvement in selectivity and quality is noted. In extreme cases, where the oscillator tube is delivering a large amount of energy, a .5 megohm leak will be required, but it has been found that for the average run of tubes a .1 megohm resistance is the correct value.

The rotor of the coupler should now be adjusted for critical coupling, which

.0005 mfd. was dissected and a few of the plates removed, so that the minimum capacity was approximately 30 mmf. and the maximum around 100 mmf. The small adjusting screw provided with the condenser will permit changing the capacity to suit the circuit, and it should be set at a point where the changing of the oscillator dial from one side band to the other will not affect the secondary tuning.

Having adjusted the oscillator system and the rotor of the coupler for the wave-length range from 200 to 600 meters, it becomes necessary to adjust for the shorter waves. Remove the long wave oscillator coil and insert the coil designed to cover the range from 50 to 150 meters. The tap on the loading coil may be brought out to a terminal block located on the rear of the shelf, the antenna lead being connected through the series condenser to whatever terminal corresponds to the correct tap on the coil. The antenna should be connected so that only 15 turns of the loading coil are in the circuit, and the secondary coil tap adjusted so that but 10 turns are connected across the secondary condenser. This will mean dead end losses, to be sure, but the intermediate amplifier provides so much amplification that such losses can be tolerated in order to obtain the desired simplicity of the tuned circuit.

If the antenna is about 75 feet long, measured from the far end through the receiver to ground, the antenna system should tune over a range from 50 to 200 meters, with the 15 turn load coil. With the entire loading coil and secondary in the circuit the range is from 180 to 580 meters. Where waves from 150 to 300 meters are desired, the use of an oscillator coil having the 100-300 meter range is recommended, so that the oscillator settings will be near the center of the scale, and the secondary turns should be increased to 24. If the antenna circuit does not tune satisfactorily at the waves between 50 and 200 meters, the tap taken out on the loading coil may not be at the proper point and in that case a little experimenting will soon show the proper amount of loading inductance which should be in the circuit.

The completed set should be fastened to the cabinet by means of four machine screws, with acorn nuts, as shown in the picture of the front panel layout. At each end of the cabinet, strips of wood at least 1/2 in. wide should be fastened

(Continued on page 81)

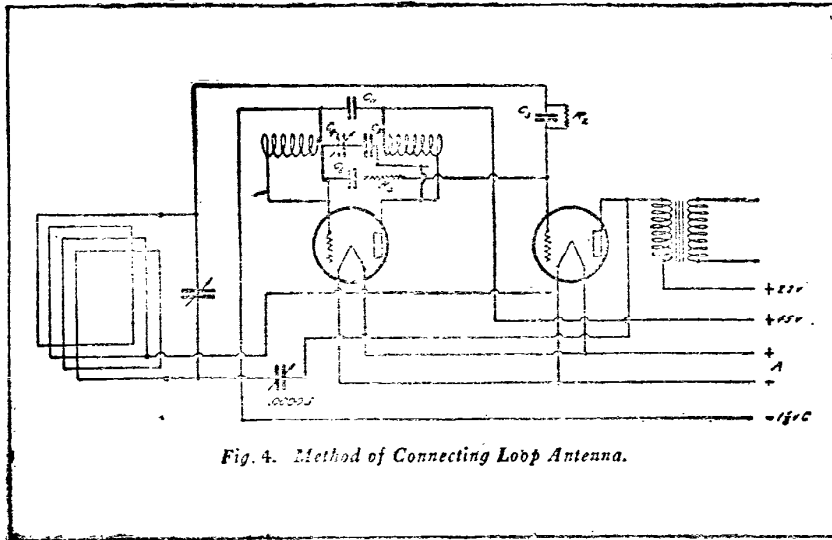

Fig. 4. Method of Connecting Loop Antenna.

adding neatness to the appearance of the finished job. All high frequency wires, as well as the detector and audio amplifier grid and plate leads were run in No. 14 bare copper wire. Where there was danger of two bare wires touching each other, or some of the apparatus, spaghetti was used, but otherwise is not necessary. When wires had to be run through the metal shelf or partitions they were passed through 1/4 in. holes drilled in the sheet metal and fitted with small bakelite or hard rubber bushings turned out on a lathe. If this procedure is too much trouble, spaghetti may be used instead of the bushings without appreciable difference.

Upon completing the wiring, a careful check of all leads should be made, and one of the tubes inserted in each socket in turn, with the A battery connected. It is also a good plan to connect the plus A battery lead to the 22, 45 and 90 volt leads in turn, examining the filament of the tube to see that it does not light. If the filament lights while the A battery is connected to the B terminals there is a short circuit somewhere in the wiring which should be located before the B battery is actually connected to the set.

Connect the antenna to the terminal provided for and make sure that the shield is grounded and connected to the common point of the rotor and stator windings of the variocoupler. Insert a .1 megohm grid leak in the mounting at the rear of the oscillator compartment and place all the vacuum tubes in their sockets. Turn on the filament rheostat and adjust the filament circuit to 3 volts, with voltmeter as a guide. Plug in the headset in the output jack and turn the oscillator dial until a local station is heard. Set the antenna and secondary condensers for maximum volume and adjust the volume control rheostat until the volume in the headphones is of the proper value. It may be that the grid leak connecting the oscillator and frequency changer is too small, in which case the local station may seem unduly broad in tuning, or else the signal is

will be at a point somewhere near its right angle setting with respect to the secondary coil. At this point the signal will suddenly become weaker and the secondary adjustment more critical, so that the coupling should be set at a point before the signal drops in volume. This adjustment will give a surprising degree of selectivity and need not again be touched even for the shorter wave-lengths.

In case the grid condenser C3 in the frequency changer circuit is of too large a capacity, a different setting of the secondary condenser will be noted for each side band setting of the oscillator, these two settings being noticeable at the higher wave-lengths. The only remedy is to reduce the capacity of the condenser. For convenience in the experimental layout, a variable XL grid condenser normally ranging from .0015 to

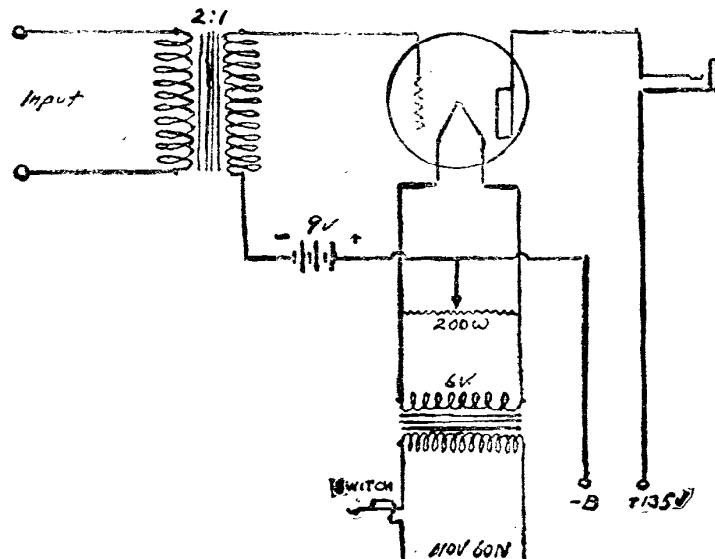

Fig. 5. One Stage Power Amplifier for Use with Receives.

The Modified Best Superheterodyne

By GERALD M. BEST

Part II—Baseboard Model

Complete Constructional Details for a New Eight-Tube Loop Model Covering the Range from 50 to 600 Meters

DUE to the greater ease of assembly and wiring, a baseboard model Superheterodyne is more popular than the shielded, panel-mounted set described on pages 53 to 57. The important modifications,—the improved oscillator system and the grid condenser and leak specified for the frequency changer—are incorporated in the new design, so that it is possible either to make these changes in sets constructed in accordance with previous directions, or build an entirely new set, as the reader prefers.

This is intended primarily as a loop receiver, although a separate antenna adapter may be added if desired. It requires only two tuning controls and with its two stages of audio frequency amplification, can be connected directly to the loud speaker.

The set has been designed to employ eight tubes, five of the C-301-A or UV-201-A type and three of the UV-199 or C-299 type, the latter being the most satisfactory intermediate frequency amplifiers where elaborate shielding is not used. Rheostats are minimized by the use of automatic filament cartridges. If

it is desired to use large tubes throughout, it is better to use two intermediate stages, which will permit the omission of the voltmeter and 30 ohm filament rheostat necessary for the proper control of the small tubes.

The general appearance of the panel is shown in Fig. 1, the oscillator and loop tuning condensers being at the left end with the feedback condenser mounted above them. To the right of the tuning controls are the volume control,

filament rheostat and voltmeter, with the three output jacks arranged symmetrically below the rheostats, and the filament switch below the voltmeter.

Fig. 2 shows the drilling template for the panel. Many of the holes designated are for specific makes of apparatus, so that when the panel is ready for drilling, the templates generally furnished with each piece of apparatus should be used so as to make sure that the holes will be drilled in the right positions.

The illustrations show the appearance of the completed set, and will be of assistance in properly arranging the apparatus. The side view shows the method of mounting the oscillator coil, and the position of the frequency changer tube in back of the loop tuning condenser. In order to shorten the leads where possible, and simplify the work of wiring, the oscillator and frequency changer are mounted on the baseboard back of their respective panel controls, and while this does not lend to symmetry in the arrangement of the tubes, the increase in efficiency from shorter leads is obvious.

The shelf for the intermediate frequency tubes is made only large enough for three 199-type sockets, the detector tube being mounted on the baseboard. If intermediate frequency transformers of a type other than those shown are used, where the terminals are near the base of the transformer, it may be possible to omit the shelf and yet retain short grid and plate leads. This can best be determined when the parts are purchased.

Fig. 3 shows the schematic wiring diagram, which does not differ materially from that described on pages 53-57. The oscillator tube is at the left, and is controlled by variable condenser C2 .0005 mfd., in series with protecting condenser C4 .006 mfd., the latter preventing the vacuum tubes being burned out in case the air condenser plates become shorted. Energy from the oscillator is fed into the frequency changer by means of a .1 megohm resistance R3 in series with a fixed condenser C5, which is made large enough so that it will not affect the total resistance of the circuit between the grids of the oscillator and frequency changer.

The loop antenna is tuned by condenser C1, which is the same size as C2, the grid condenser C3 being a variable of not over 50 micromicrofarads (.00005 mfd.) maximum and the grid leak R2 from 2 to 3 megohms, depending on the tube. A center tap loop is employed.

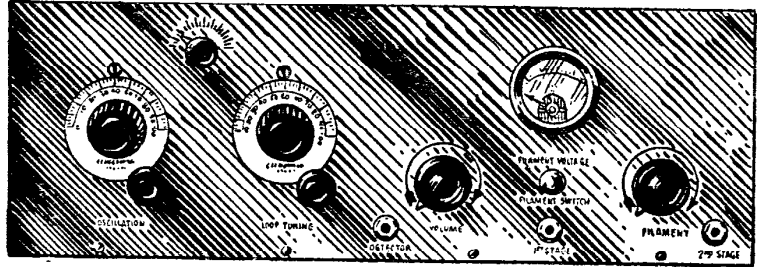

Illustrations by Courtesy of Radi. Fig. 1. View of Panel Front.

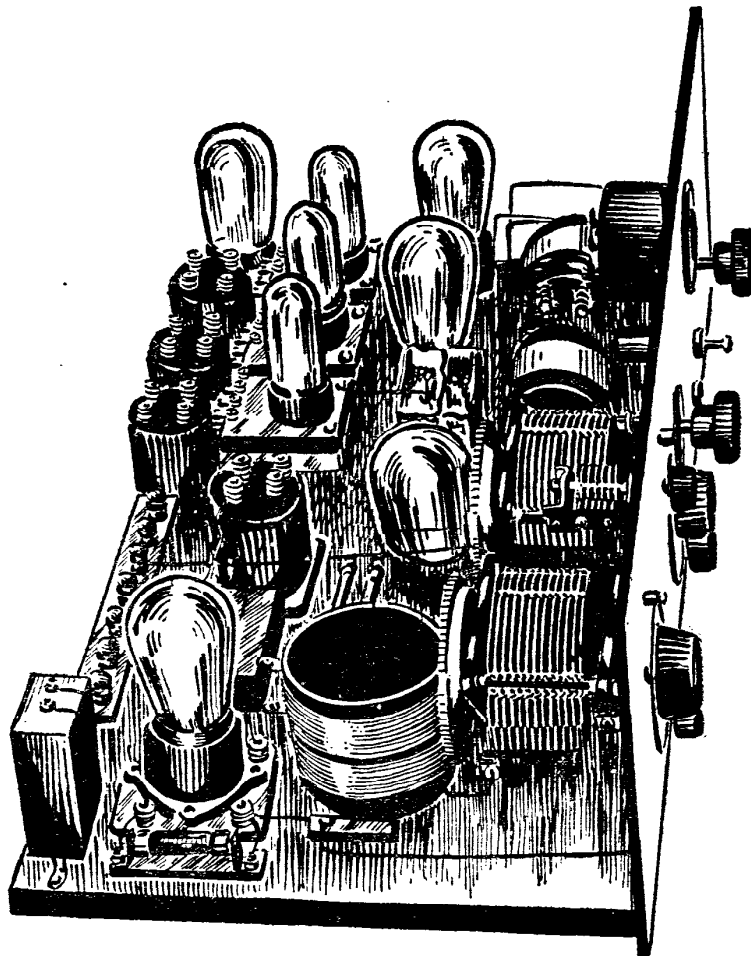

End View of Receiver, Showing Oscillator System.

energy being fed from the plate of the frequency changer through a small air condenser C10 having a maximum capacity of .00005 mfd., to one side of the loop antenna. The center tap of the loop is connected directly to the positive filament of the frequency changer.

The three intermediate frequency stages are transformer coupled, using transformers either of the shielded type or open core non-shielded, as desired. The tuned stage should be of the proper design to match the intermediate stages, and the tuning condenser C7 should be of the value specified by the manufacturer, the value shown on the diagram being for the particular transformer used in the experimental layout.

The volume control is obtained by means of a 2000 ohm potentiometer shunted across the second intermediate stage, the potentiometer being arranged so that the circuit is open when the slider reaches its maximum position.

The three intermediate tubes are of the dry cell type and are controlled by a 30 ohm rheostat R1. The detector tube

ample, but for large rooms and where a cone type loud speaker is used, the additional plate voltage and 9 volt C battery should be supplied for best results. The new UX-112 tube recently announced will increase the output of the set if used in the last audio stage and requires a .5 amp. Type 112 Amperite in place of the .25 ampere size.

The by-pass condensers C6 and C11 are shunted across the plate battery supply to the frequency changer and oscillator tubes respectively. If trouble due to high resistance in the B battery circuit is experienced, with resultant howling in the audio frequency stages, a small by-pass condenser of .006 mfd. or more may be connected from the positive B battery bus at the transformers, to the negative filament leads to the audio frequency tubes. This will also be necessary in case a protective resistance is placed in the B battery circuit, as was done in the shielded model.

Many of our readers find it difficult to wire up receivers from schematic diagrams, and so we have prepared a pic-

necessity for special parts.

The connections to the grid and plate of each intermediate frequency tube and to the detector should be made with bare wire, but the filament wiring may be bunched together, as can the grid and plate battery bus wires. On account of their small size, a pair of 4½ volt flashlight batteries were used for furnishing C voltage, the 1½ volt tap being obtained by scraping away a small amount of the cardboard covering of one of the batteries, at the end next the positive terminal, and soldering the connection to the zinc case of the battery.

The apparatus on the baseboard should be mounted as shown on the pictorial diagram, the shelf going in place after the wiring of the audio frequency transformers and associated tube sockets is completed. Make the connections for the oscillator and frequency changer in bare wire, using spaghetti only where it is necessary to prevent wires from touching each other. After the oscillator and frequency changer wiring is complete, make as many of the connections as pos-

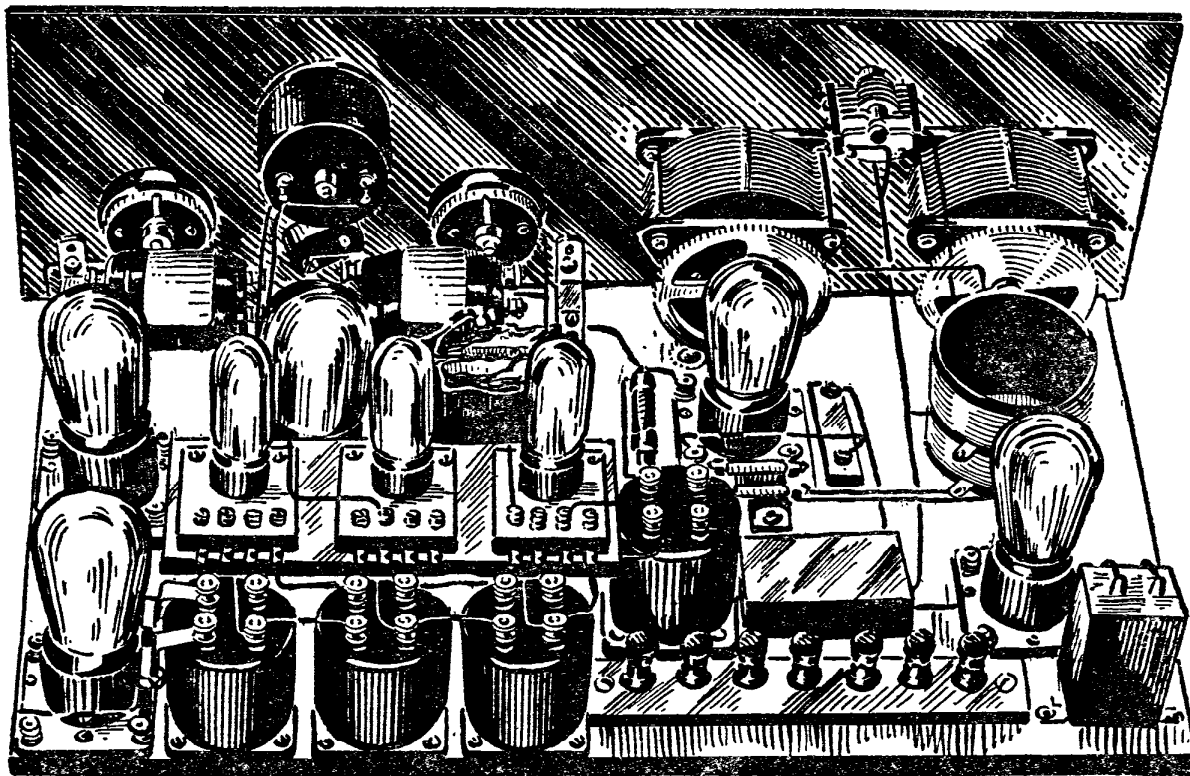

Rear View of Baseboard Model.

is of the storage battery type, the filament current being controlled by an Amperite in the same manner as for the oscillator and frequency changer. The grid condenser C8 should be .00025 mfd. and is shunted by a grid leak R4 of 3 megohms. In the plate circuit of the detector tube is the radio frequency by-pass condenser C9, which is shunted across both the primary of the audio frequency transformer, and the 45 volt B battery, so that the high frequency component in the detector plate circuit is localized within the set.

The two audio stages are connected in the conventional manner using shielded transformers such as the Karas Harmonik or other recently developed high quality makes and the tubes being storage battery type, supplied with either 90 or 135 volts plate, depending upon the volume required. Where normal room volume with a horn type speaker is required, 90 volts plate and 4½ volts C battery is

sible to the intermediate frequency transformers and detector circuit, and then mount the tube shelf in place behind the intermediate transformers. The list of parts given on page 18 will enable the selection of apparatus suitable for the circuit. No specific recommendation of any of the parts listed is implied, and the set will function satisfactorily with any of the parts named in the list.

As soon as the wiring is completed the A battery should be connected, and the tubes placed in their sockets. The automatic filament cartridges should be of the .25 ampere type, with the exception of a .5 ampere size in the last audio stage, and each one should be checked by shorting it out of the circuit temporarily. If the filament of the tube associated with the cartridge becomes brighter, the cartridge is O. K. The filament rheostat R1 should be capable of reducing the voltage of the three 199-type tubes below 3 volts, with the A

torial diagram, Fig. 4 in vertical perspective, showing the actual wiring for each piece of apparatus, each part being plainly marked with respect to the schematic diagram in Fig. 3. The picture is distorted in places to permit all the connections to be shown clearly.

In assembling the set, the panel apparatus should be mounted first, and the connections to the jacks soldered before the panel is mounted on the baseboard, as some of the jack connections will be difficult to reach unless the wires are soldered first. Flexible wire is handy for these connections, and should be well insulated.

The tube shelf is made of wood, the dimensions being 2¼x7x¼ in., and is supported by two brass brackets, the details of which are given in Fig. 5. In mounting the binding posts at the rear of the baseboard, a convenient strip of 7 posts equipped with supports and mounting screws was used, thus obviating the

As soon as the wiring is completed the A battery should be connected, and the tubes placed in their sockets. The automatic filament cartridges should be of the .25 ampere type, with the exception of a .5 ampere size in the last audio stage, and each one should be checked by shorting it out of the circuit temporarily. If the filament of the tube associated with the cartridge becomes brighter, the cartridge is O. K. The filament rheostat R1 should be capable of reducing the voltage of the three 199-type tubes below 3 volts, with the A

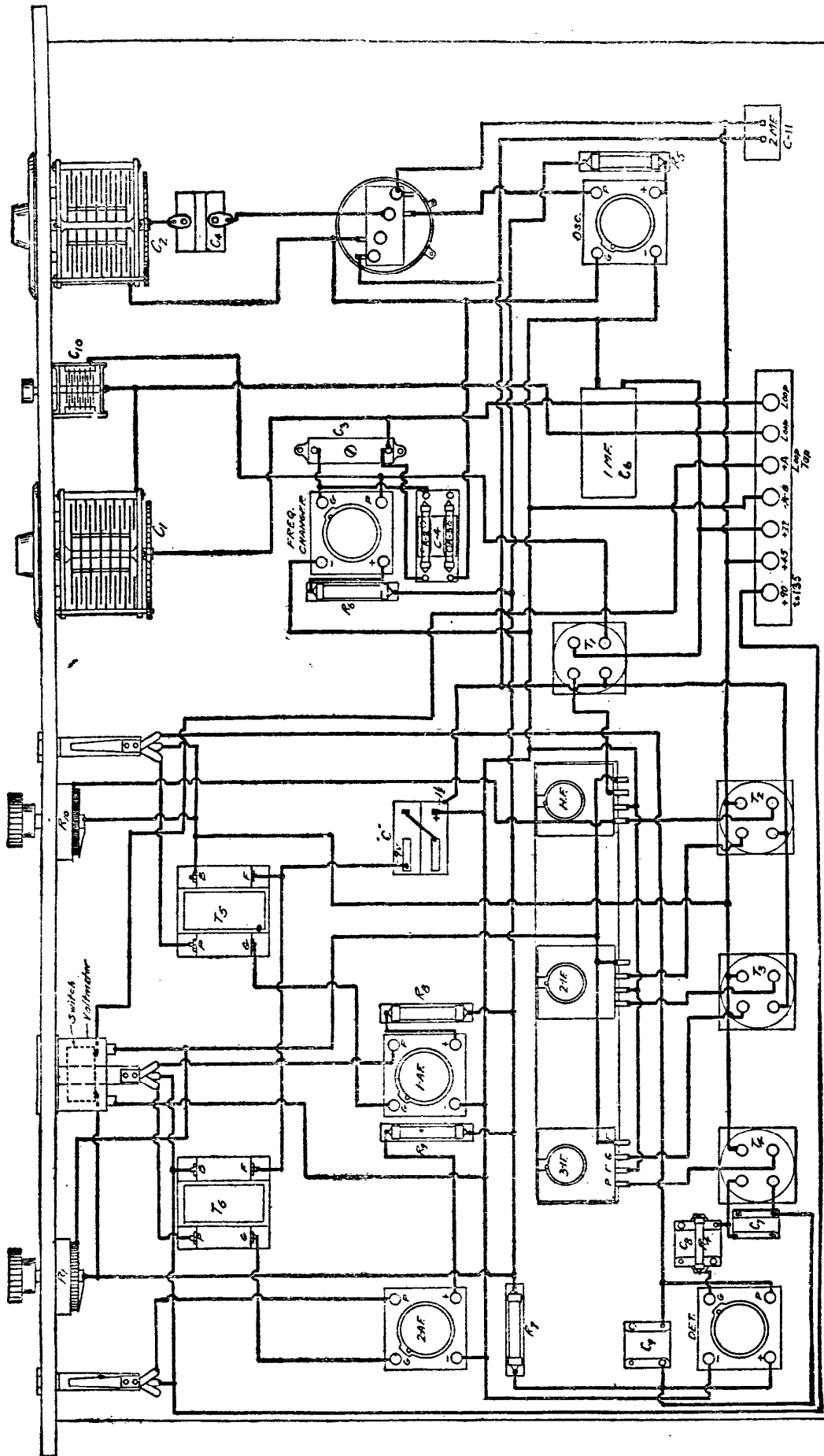

Fig. 4. Pictorial Wiring Diagram, Showing All Connections.

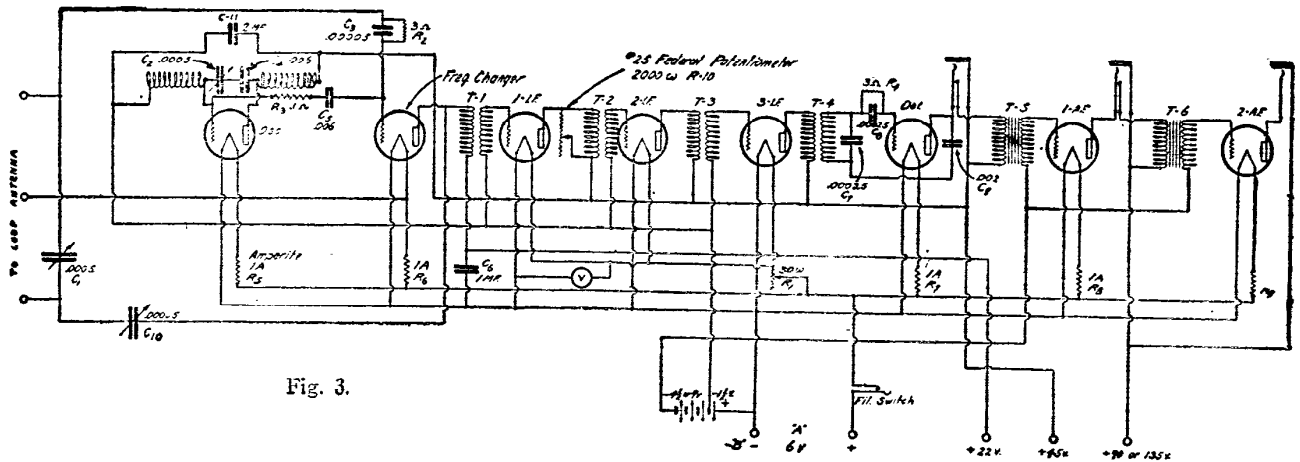

Fig. 3.

battery fully charged, and if this cannot be accomplished, a rheostat of higher resistance should be substituted.

After the filament circuit is found to be correct, connect the positive A battery to the 22 volt binding post, and see that the filaments of the tubes do not light, for if any of the tubes should light, there is a short circuit in the set and it should be located before connecting the B battery. Connect the positive A battery to the 45 volt and 90-135 volt terminals and repeat the above test, and if no trouble develops it is safe to connect the B battery, and the loop antenna.

After placing the tubes in their sockets, turn on the filament switch and adjust the intermediate frequency tubes to 3 volts. Plug in the headphones in the first audio jack, and set the volume control at a point about one-third between zero and maximum. Tune in a local station to maximum, with the oscillator and loop controls, and reduce the volume to a point where it will be comfortable with the headphones.

Move the oscillator condenser back and forth slightly to observe the degree of selectivity of the oscillator system, and if the two points where the station can be tuned in on the oscillator condenser appear to be broad, too much oscillator energy is being fed into the frequency changer, and it will be necessary to change the resistance R3 to some higher value than .1 megohm. Grid leaks of .25 and .5 megohms are easily obtainable and one of these values will be sure to provide the correct resistance for the oscillator circuit. If the volume control is set at too high a point, the tuning will be broad under any circumstances, so it is better to have the volume low when making this adjustment.

As has been explained many times,

with the Superheterodyne receiver a station can be tuned in at two places on the oscillator condenser dial, one setting being 45,000 cycles above the incoming frequency and the other 45,000 cycles below this frequency, when the intermediate amplifier is tuned to 45,000 cycles. Signals should be received at about the same degree of intensity at either point on the dial, and if it is found that this is not the case, grid condenser C3 may be more than .00005 mfd., and should be adjusted to a lower value of capacity.

The adjustment of condenser C10 may

coil, and turn the feedback condenser until the set breaks into oscillation. Then back off the capacity slightly and you have the proper adjustment for the longer waves. If the set oscillates continuously at all times, this condenser may be defective and should be temporarily cut out of the circuit to see if the oscillations will cease. If the oscillator tube does not oscillate, and no stations are heard at any setting of the oscillator condenser, the trouble may be due to a defective tube, or incorrect wiring of the oscillator coil. Try reversing the con-

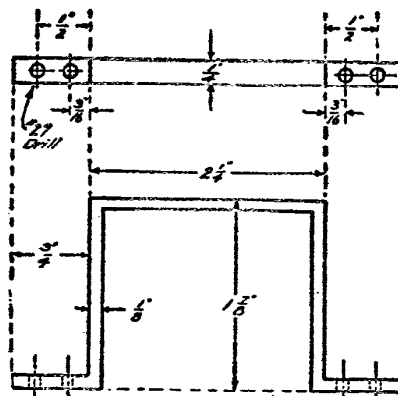

Fig. 5. Details of Brackets for Shelf.

be made from time to time, while tuning distant stations, or can be left in a permanent position, as desired. If the latter is preferable, adjust the set to the lowest wave-length at which the set is to be operated, with any given oscillator

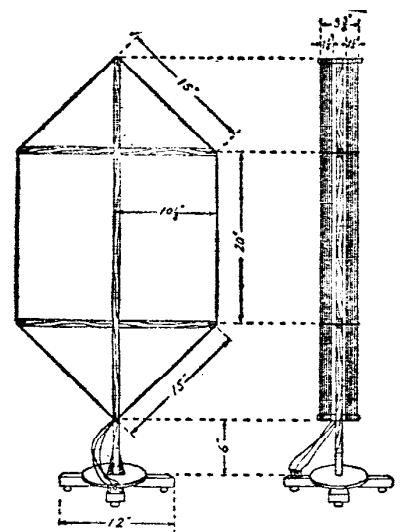

Fig. 7. Center Tap Loop Antenna.

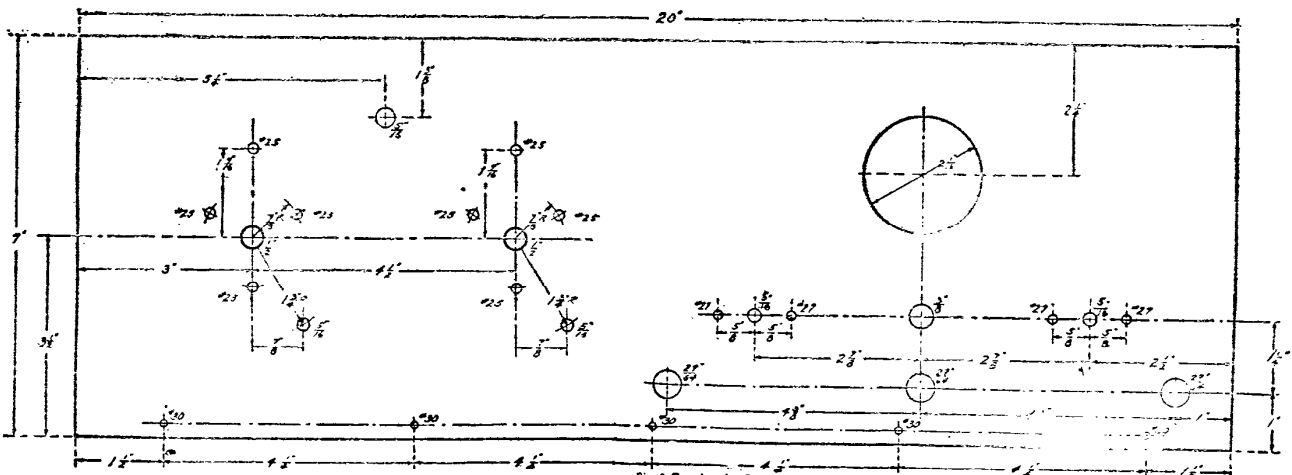

Fig. 2. Template for Drilling Points.

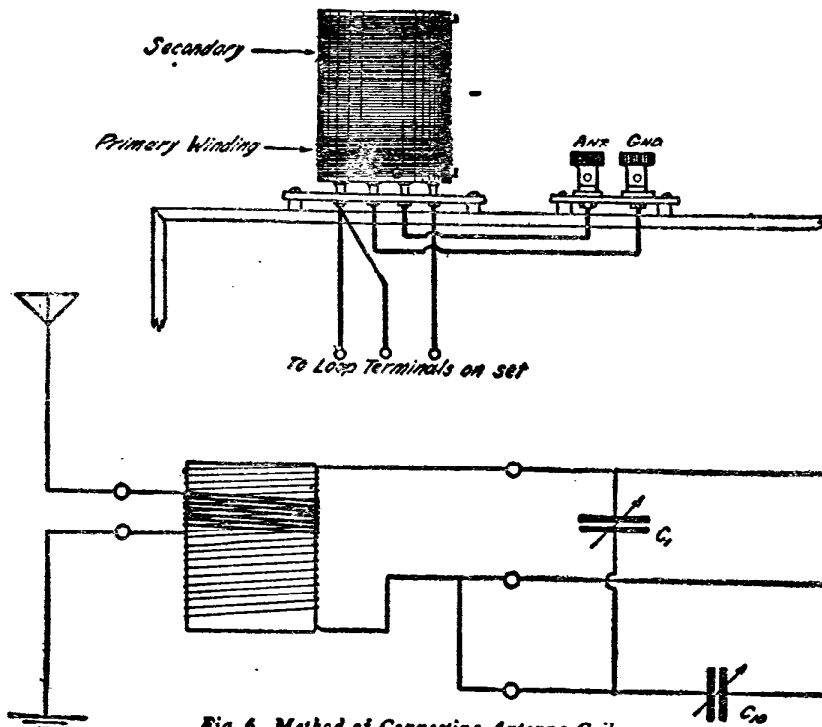

Fig. 6. Method of Connecting Antenna Coils.

PARTS FOR THE MODIFIED BEST SUPERHETERODYNE BASEBOARD MODEL

No. Required	Part	Circuit Designation	Makes That May Be Used
3	I. F. Transformer	T_1, T_2, T_3	Baldwin, Pacific, General Radio No. 271, Jefferson No. 150, Remler, Silver 60 KC.
1	Tuned Transformer	T_1	See Text.
2	Audio Freq. Transf.	T_2, T_3	All-American, Dongan, General Radio, Jefferson, Karas Harmonik, Pacent, Premier, Rauland Lyric, Stromberg-Carlson, Supertran, Thordarson 2:1.
3	Jack		Carter, Erla, Federal, Frost, Marco, Pacent.
3	Oscillator Coils		General Radio No. 277-A, B and C.
1	Oscillator Coil Mtg.		General Radio No. 274-B.
1	Rheostat	R_1	Amsco, Bradleystat, Carter, Federal, Frost, General Instrument, General Radio, Pacent.
2	Variable Condensers	C_1, C_2	Acme, Bremer-Tully, Camfield, Cardwell, Ensign, General Instrument, General Radio, Karas, Marco, National, N. Y. Coil, Phoenix, Remler, Signal, Silver-Marshall, U. S. Tool.
3	Tube Sockets, Plain Type 199		Amsco, Benjamin, Erla, Frost, General Radio, Kellogg, Marco, Remler, Silver-Marshall.
5	Tube Sockets, Cushioned Voltmeter		Benjamin, Frost.
1	2 mfd. Fixed Cond.	C_3	Hoyt Model 17, Jewell Pattern 135, Weston Model 506 or 301.
1	1 mfd. Fixed Cond.	C_4	Dubilier, Kellogg, N. Y. Coil
1	.00025 mfd. Fixed Cond.	C_5	Dubilier, Electrad, Kellogg, N. Y. Coil, Federal.
2	.006 mfd. Fixed Cond.	C_6, C_7	Dubilier, Electrad, Federal, Hilco, Kellogg, N. Y. Coil.
1	.002 mfd. Fixed Cond.	C_8	Dubilier, Electrad, Federal, Hilco, Kellogg, N. Y. Coil.
1	.00025 mfd. Fixed Cond. with G-L mtg.	C_9	Dubilier, Electrad, Federal, Hilco, Kellogg, N. Y. Coil, XL.
2	.00005 mfd. Var. Cond.	C_{10}, C_{11}	Amplex, Continental, XL Model G, Chelton.
2	Grid Leak-3 megohm	R_2, R_3	Aerovox, Amsco, Daven, Durham, Electrad, Filko, Freshman, Rogers.
1	Grid Leak-.1 megohm with mounting	R_4	Aerovox, Amsco, Daven, Durham, Electrad, Filko, Freshman, Rogers.
1	Potentiometer, 2000 ohms	R_{11}	Centralab, Federal.
7	Binding Posts		Amsco, Eby, General Insulate, General Radio.
4	Automatic Fil. Cart-ridges	R_5, R_6, R_7	Amperite No. 1A.
1	" " " "	R_8	Amperite No. 112.
2	"C" Batteries	R_9	Eveready No. 751.

nections to one of the windings of the coil, in case this trouble develops.

For covering the entire wave-length band from 50 to 600 meters, three oscillator coils are necessary, instructions for winding being given on pages 54 and 55. They may also be purchased ready wound, if it is not desired to make them.

For the wave-lengths between 50 and 200 meters, it is often a good idea to employ an outdoor antenna in place of the loop, as the loop would require taps for the short waves, and is not particularly efficient when used in that fashion. Hence, a simple antenna tuned circuit may be mounted on the back of the cabinet as shown in Fig. 6, and flexible connections may be brought inside the cabinet to the loop terminals on the binding post strip. The antenna coil for 50 to 125 meters should consist of 15 turns of No. 22 wire wound on a 2 3/4 in. tube, connected in place of the loop antenna, with a small aperiodic primary made up of 4 turns of No. 22 wire wound over the secondary at one end of the coil. For 100 to 300 meters, the antenna coil should be 30 turns of No. 22 wire on a 2 3/4 in. tube, with a primary of 8 turns, and for 200 to 600 meters the secondary should be 60 turns and the primary 10 turns. In using the antenna adapter for the broadcast range from 200 to 600 meters, employ a small indoor antenna, for the aperiodic primary is not sufficiently selective for use with a large outdoor antenna at these waves, and the loop antenna is preferable, or an arrangement having a tuned primary such as was described for the shielded model. When the antenna coils are in use, it should be noted that condenser C10 is not used, as no particular advantage is to be gained by regeneration and the coil connections will be too complicated for ease in mounting on the back of the cabinet.

A number of well made loop antennas are now available on the market, and most of them are equipped with a center tap. The purpose of the center tap is to provide a means for reducing the resistance of the loop, by the use of capacity feedback from the frequency changer tube. Energy from the plate circuit of the frequency changer is fed through the variable condenser C10 to one side of the loop which is divided into two sections by the center tap. The feedback reduces the high frequency resistance of the loop practically to zero when adjusted properly, and enables reception over much greater distances than would otherwise be possible. Those wishing to construct their own loop will find the dimensions shown in Fig. 7 useful, the loop being wound with 12 turns of No. 18 single fixture wire, or other stranded wire of equivalent size, the total amount required being about 105 feet, including flexible leads. The center tap should be taken off at the end of the 6th turn, at the bottom of the loop.

If the receiver is to be used for amateur C. W. reception on the shorter waves, a separate beating oscillator should be mounted adjacent to the set and operated from the same A and B batteries. This oscillator should be arranged to work at approximately the same frequency as that used for the intermediate frequency amplifier, and should have an adjustable range at least 3000 cycles above and below the critical frequency, so that an audible beat note can be produced. In order to prevent too much of the beating oscillator energy from entering the intermediate circuit, a by-pass condenser of 2 mfd. should be shunted across the B battery terminals at the beating oscillator, and another condenser of like value should be bridged across the filament leads at the same point.

Improvements in the 45,000-Cycle Superheterodyne

By G. M. BEST

A LARGE number of suggestions for the improvement of the 45,000-cycle Superheterodyne, described on pages 48-52 of this book, have been received since its first publication. It is unfortunate that most of these suggestions call for the use of the UV-201A or C-301A tubes, which require a storage battery. The set was originally designed as a dry battery receiver, and the addition of a storage battery, with its associated rectifier or other charger, does not constitute an improvement.

While there is no doubt that the use of the larger tubes, with their higher amplification constant and mutual conductance, will increase the amplification per stage in the intermediate frequency amplifier, not enough gain will be obtained to warrant the extra expense of the battery and charger. Of course, many already have a storage battery and probably would prefer to use it instead of the dry cell. In that case, great care in constructing the set will be necessary, and a considerable amount of shielding will be required, due to the larger amplification obtained. It would be advisable to shield the back of the panel, the baseboard section containing the oscillator coupler, oscillator tube and oscillator air condenser, and the inside of the cabinet.

The best suggestion, yet received, for improvement of the dry cell set, is the addition of a four-spring telephone jack, on the panel, for the purpose of bringing out the voltmeter terminals in a manner so that a plug, with flexible cord and clips attached, may be inserted in the jack, and the voltmeter, which is disconnected from the filament circuit, may be used for measuring C batteries, or any other battery desired. This jack, and its connections, is shown in Fig. 1.

The jack may be a Federal 1423-W, or any other jack of similar number of springs, and contact arrangement. The two main springs of the jack go to the

voltmeter terminals, and the two contacts are connected to the main filament leads in the set, so that normally the voltmeter is connected to the filament circuit. When the plug is inserted in the jack, the voltmeter is disconnected from the filaments, and can be used for

give an erroneous reading if so used. The only way to measure the voltage drop across such resistances, without the use of an expensive high resistance voltmeter, is to measure the current flowing through the resistances, with a milliammeter, and compute the voltage by the

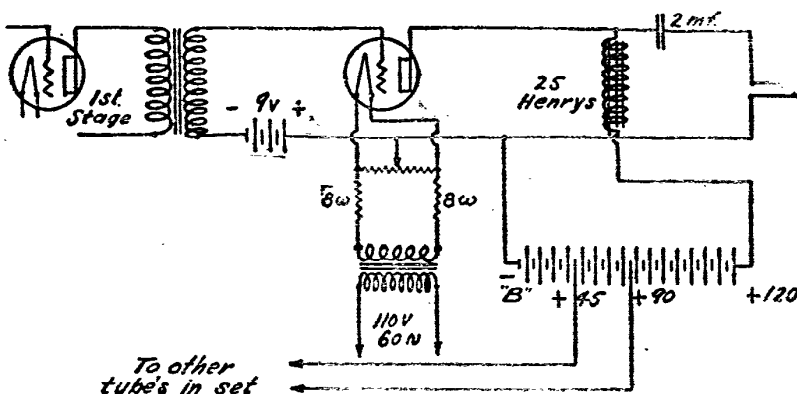

Fig. 2. Power Amplifier Hook-up

any other purpose, up to its maximum scale.

This voltmeter cannot be used for measuring the voltage drop across the biasing resistances suggested in the article on the modified receiver, as the voltmeter is a low resistance affair, and will

well known formula $E = IR$, where E is the unknown voltage, I is the measured current, and R is the known resistance.

Another suggestion of merit, primarily intended for those who desire a large volume out of their audio-frequency amplifier, is the addition of a power amplifier, partly operated from A.C., in place of the last dry cell tube in the audio-frequency stages. The circuit for this amplifier is shown in Fig. 2. The amplifier consists of a UV-201A or C-301A vacuum tube and associated socket, a choke coil of 25 henrys or more (a G. E. Wayne Bell Ringing transformer primary winding will do), a 2-microfarad condenser, a small bell ringing transformer, two Cutler-Hammer 25-ohm variable resistances, and a 200-ohm potentiometer.

The plate voltage applied to this stage should be at least 120, for 9 volts negative grid potential. As there are several makes of bell ringing transformers on the market, with secondary voltages

(Continued on page 80)

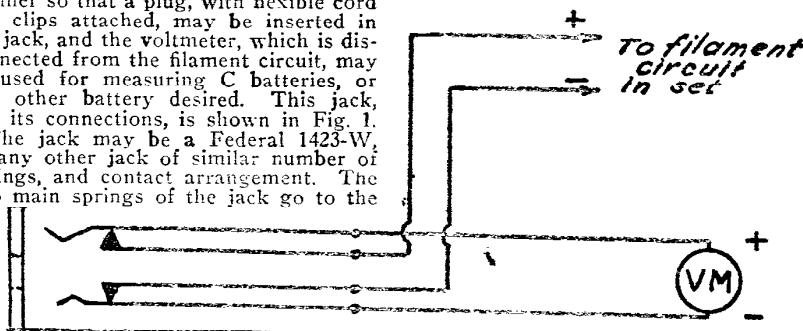

Fig. 1. Voltmeter Jack Connections

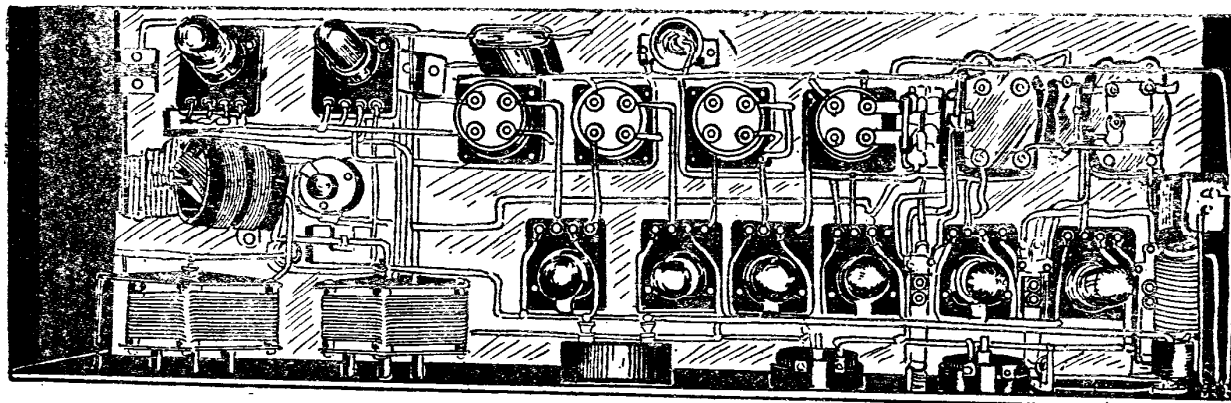

Fig. 3.—Suggested Rearrangement of Parts.

Illustrations by Courtesy of Radio

More Improvements In Best's 45,000 Cycle Superheterodyne

By G. M. BEST

A NUMBER of very good suggestions for the improvement of the Superheterodyne receiver described on pages 48-52 have been received, and have been incorporated in a revised circuit diagram, similar to that shown in Fig. 3 on Page 49 of the original article. This revised circuit is shown in Fig. 1 on this page, with the various suggested changes.

The suggestion which wins first prize for value is a change in the volume control, to increase the stability of the set, and provide a more even, smooth control of the volume. In the original circuit, the filaments of the three intermediate frequency amplifiers and the first detector were placed in the volume control rheostat circuit, and it has been found that changing the filament current of the first detector tube changed the output impedance of the tube to such an extent that the small feedback condenser C3 often was of the wrong capacity value for a given setting of the volume control rheostat and the set would occasionally oscillate. By removing the negative filament connection of the first detector tube, and the last intermediate frequency amplifier, from the volume control circuit, and connecting the filaments as shown in the diagram, this instability is eliminated, and much more satisfactory results can be obtained. A rheostat of 25 ohms resistance should be substituted in place of the Federal No. 18 rheostat in the volume control circuit, in order to provide sufficient resistance for cases where the set is to be operated very close to a high-powered station. A Federal No. 22 rheostat will serve very well in this part of the circuit.

The next best suggestion was to employ a common C battery, instead of the three C batteries as described in the May issue. This common C battery connection is shown in the revised circuit, and should preferably be an Eveready No. 771 C battery, with a special tap taken out at the first negative 1½-volt cell terminal, so that the intermediate frequency amplifier and the oscillator are provided with 1½ volts negative grid potential. The entire 4½-volt battery provides negative grid potential for the first detector tube and the two audio-

frequency amplifiers. The battery should be located on the baseboard, in approximately the position now used for the 4½-volt C battery in the first detector tube circuit. As the No. 771 battery is not provided with a tap at the 1½-volt point, it will be necessary to scrape away the compound on the top of the battery unit until the 1½-volt terminal is exposed.

The third best suggestion was to incorporate a telephone jack of the four spring variety, so that the last audio-frequency transformer could be entirely eliminated from the circuit when not desired, and this jack is shown in the circuit diagram on this page. The jack may be a Federal No. 1423-W, or any other good make of jack with the proper spring contacts. The open circuit phone jack already in the set may be placed in multiple with the phone tip jacks, on the output of the last tube, so that a pair of phones employing a plug may be inserted in the last stage, at the same time that the loud speaker is connected to the phone tip jacks.

A LARGE number of questions have been received from readers on the subject of the use of C-301-A or UV-201-A tubes instead of the "dry cell" tubes. There is no reason why the "A" type tube cannot be used in the circuit, provided the proper sockets are used, and a filament rheostat capable of carrying 2 amperes is provided. The use of "A" tubes will of course require a storage battery, as eight tubes will draw .25 amperes each, making the operation of the set from dry cells very uneconomical. The same values for the B and C batteries should be used, and the B battery voltage applied to the intermediate frequency amplifier should not exceed 45 volts under any circumstances. The intermediate frequency amplifier will not give any greater amplification with the "A" tubes than with the C-299 tubes, for, although the mutual conductance of the "A" tube is higher than the C-299, the intermediate frequency transformers work best with a tube of higher impedance than the "A" tube, and hence the gain obtained by the use of the storage battery tube will be offset by reflection losses in the output circuit of

each intermediate frequency amplifier tube.

The writer has received perhaps fifty letters asking about the use of an antenna with the Superheterodyne receiver. Except in rural districts, the addition of an antenna tuner in place of the loop will result in such an increase of noise, man-made static, from power lines, street cars, etc., and spark interference, that any increase in signal strength will be of no use, as the noise will drown it out. Fig. 2 shows the best circuit for the antenna connection, however, for there are many who do not care to build the loop and already have an antenna. The coupler shown must be of the 180-degree type to obtain best selectivity.

The most convenient coupler to use is the same set of coils as are used in the oscillatory circuit in the Super-Heterodyne receiver, the Remler No. 620 oscillator coupler being the coil recommended in the original article. The rotor should be connected to the antenna circuit, and should be placed in series with a 25-turn honeycomb coil and a 23-plate air condenser. The stator windings are connected to the input binding posts on the set, the center taps of the oscillator coil being strapped together and connected to the center binding post on the set, and the two outside terminals of the coil being connected to the top and bottom binding posts on the set. If the reader already has a good coupler on hand, the stator will probably have 50 turns, so that the tap at the 25th turn should be connected to the center binding post on the input end of the set, and the outside terminals will go to the other two input binding posts. In cities where there are many broadcasting stations, it might be desirable to unwind some of the turns from the rotor, and increase the size of the load coil. In this case, a total of 10 turns in the rotor would be sufficient and the load coil should be increased to 100 turns, an unmounted honeycomb coil being appropriate. If the oscillator-coupler is used, the rotor will not have to be unwound, as it already has the right amount of inductance. In operating the antenna tuner, use the minimum possible coup-

(Continued on page 80)

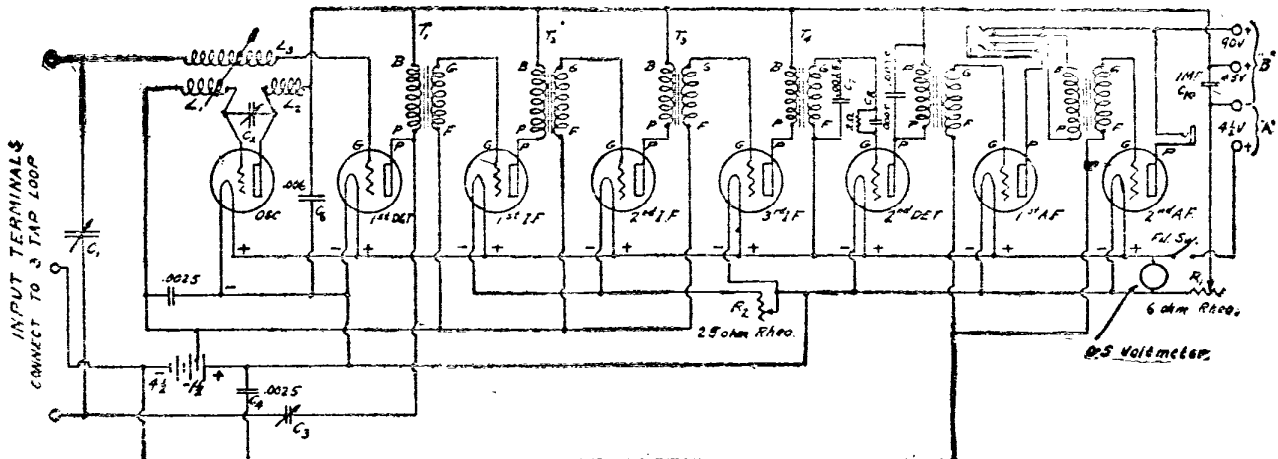

Circuit Diagram for Best's 45,000-Cycle Superheterodyne with June Prize-Winning Suggestions for Improvement Incorporated

The "Peanut" Super

By MORRIS LEVY

This peanut Superheterodyne is surely a "peanut." Although employing seven tubes, the whole outfit is very small in size, as may be seen by making a comparison of the size of the three inch dial and the total height and length of the cabinet, as illustrated below. And it positively DOES work! The secret of its compactness lies in the use of the so-called "peanut" tubes.

BEFORE describing the set, it would not be amiss to explain the title of this paper. A standard Superheterodyne circuit using seven tubes is employed. The writer believes this set is one of the smallest and most compact Superheterodynes ever constructed. The complete set is mounted on a panel measuring only 7 x 10 inches and extends 4 1/4 inches back of the panel. It is com-

plete in every way, containing two variable condensers, rheostat, potentiometer, seven sockets, two audio frequency transformers, "C" battery, three 1/2 mfd. by-pass condensers, oscillator coupler, 60 K.C., intermediate R.F. amplifying unit, two grid condensers and leaks and smaller by-pass condensers, also a three-plate variable condenser. It is really a peanut in size, compared to the 28- and

30-inch mastodons of the usual super construction.

Peanut Tubes Used

It gets its name chiefly from the fact that Western Electric peanut "N" tubes are used. They are the smallest tubes available, having characteristics more or less like the WD12 tubes, in that both types use oxide-coated filaments, operat-

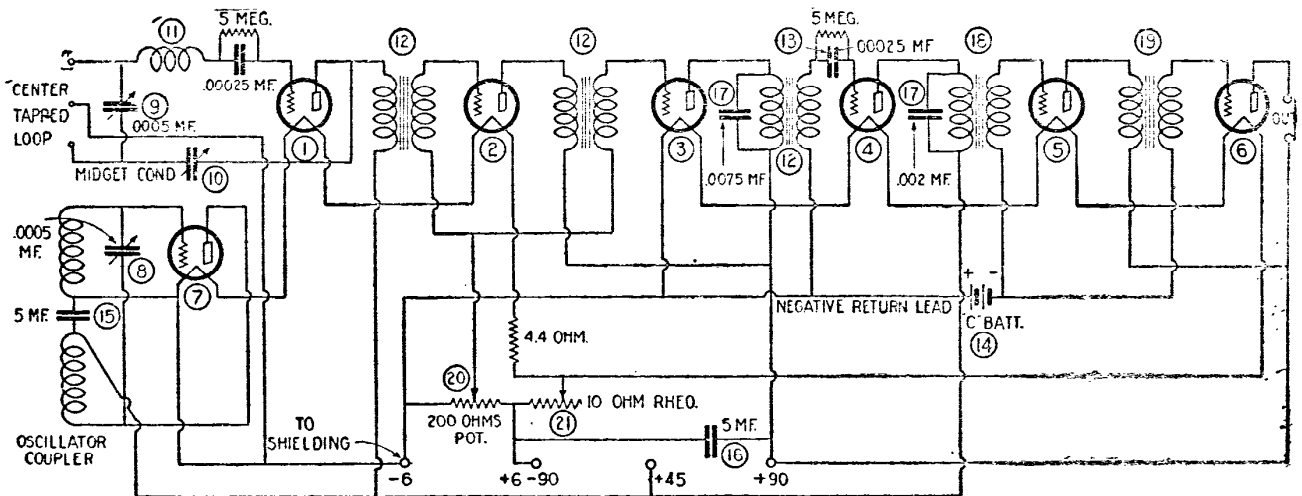

1, first detector; 2, 3, Intermediate Amplifiers; 4, second Detector; 5, 6, A.F. Amplifiers; 7, Oscillator tube; 8, Oscillator Tuning Condenser; 9, Loop Tuning Condenser; 10, Midget Condenser; 11, Grid Coil; 12, Intermediate Transformers; 13, Grid Condenser and Leak; 16, 17, By-pass Condensers; 18, 19, A.F. Transformers; 15, 0.5 mf. condenser; 14, C Battery; 20, Potentiometer; 21, Rheostat.

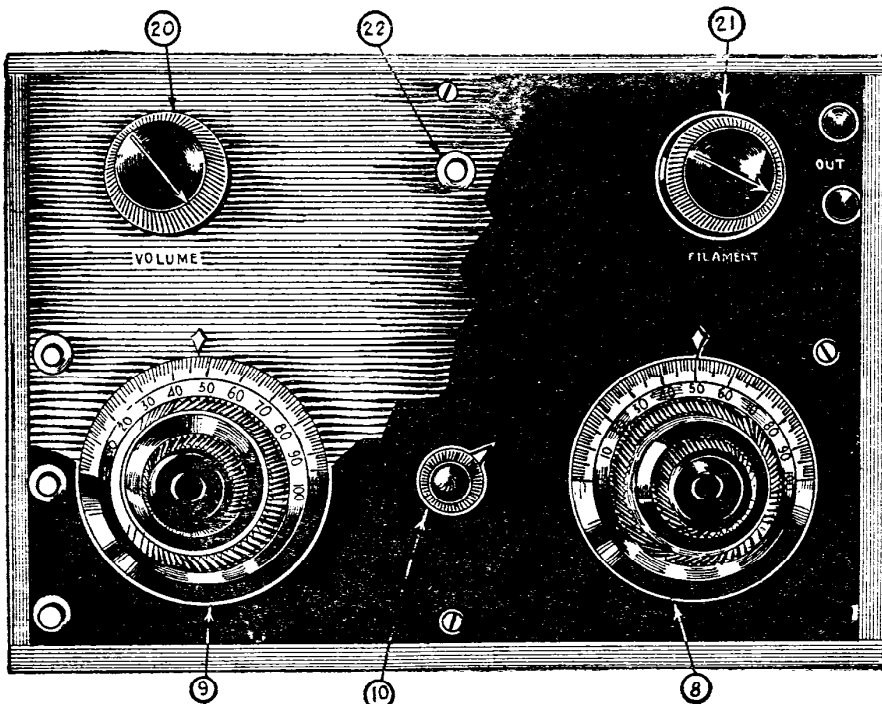

The completed receiver is very convenient as to size, and pleasing as to appearance. It will be noted that there are only two tuning controls; the remainder of the controls can be set, and allowed to "stay set." 8 is the oscillator condenser and 9 is the loop condenser. 22 is the filament switch. 20 is the potentiometer and 21 the rheostat.

ing on 1.1 volts and .25 amp. Of course, not as much volume can be expected from these tubes, as from the larger ones, and to their rather low mutual conductance, about 240 as compared with about 350 for UV199. The volume is (when using a loop) better than one step of audio amplification with larger tubes. The writer recommends that UV199 be used if difficulty is found in obtaining "N" tubes. By using UV199 sockets, it would be necessary only to move the sub-base a half-inch lower and extend it about 5 inches back instead of 4 1/4, as the writer has it. Otherwise, everything might remain the same. "N" tubes are very uniform and fairly non-microphonic, which gives them some advantage over the UV199, as the latter are notorious for both these qualities.

Split loop regeneration by the Rice method is employed. This is controlled by a small variable condenser. The loop terminals are connected to the three binding posts, on the lower left side of the panel. They can be clearly seen in the picture. The top terminal is for the center tap. The use of regeneration results in quite an improvement in signal strength. No remarkable DX results are claimed, but fairly consistent results from stations as far west as Denver have been recorded, with quite a number of them on the loud speaker. The tuning is sharp and the tone quality very good. This is for loop reception, using an ordinary 13-turn pancake-type loop, tapped at the seventh turn. By the use of an antenna coupler and loose coupling,

far better results are obtained, due to the better regenerative qualities of the coupler and use of antenna. But at this time of the year antenna reception is not recommended because of the great amount of static and noise which is picked up.

No detailed instructions will be given,

condensers of .006 and .002 connected together, which can be seen near the grid condenser, are connected across the filter of the intermediate transformer unit. These two condensers are connected to one terminal of $\frac{1}{2}$ mfd. by-pass condenser, which, in turn, is fastened under the sub-base. Another by-pass condenser

ers behind the sockets. Before proceeding to mount anything on the under side of the sub-base, mount the base on two long brackets directly on top of the two variable condensers. Having mounted this base, proceed to locate the position underneath the sub-base for the various parts to be mounted, so that they will clear the rotary plates of the variable condensers. The illustrations show how this is done. With base still mounted, place tubes in sockets, and locate positions for rheostat, potentiometer and filament switch so that they will clear the tubes.

In wiring the set, use No. 22 wire, covered with spaghetti. Make the leads as direct as possible. There isn't room enough for square bends. Use resin-core solder only. In wiring the filament circuit, the following should be taken into consideration: If "N" or WD12 tubes are used, it's possible to wire four of them in series for use on a 6-volt supply. Since there are seven tubes, they will have to be connected in two banks of four and three, in series parallel. Since one bank has one more tube, it will be necessary to place a 4.4-ohm resistance in series with the 3-tube bank so that one rheostat may control both banks and permit an equal division of current in each bank. (See diagram for filament hook-up.) The total current consumption is $\frac{1}{2}$ amp. at 5-6 volts. It is, therefore, practical to use four dry cells connected in series. If 199 tubes are used connect them all in parallel for three dry cell supply. This is an advantage when using the 199 tubes. If the "N" or WD12 tubes are connected in parallel, $1\frac{1}{4}$ amps. will be required. This prohibits the use of dry cells.

The writer's set was completely shielded, cabinet was copper lined, panel and sub-base were copper-shielded. This was found to be superfluous and the cause of considerable trouble. It is, therefore, suggested that shielding be eliminated since the R.F. transformers are shielded, and their container may be grounded, with by-pass condenser cans, etc. Shielding may be helpful, but the trouble required to keep the various parts from grounding to the shielding makes it hardly worth the trouble.

The Loop

Most loops on the market have entirely too many turns for use with a .0005 mfd. condenser. If, when using the loop, it is found impossible to tune the shorter waves and the long waves can be tuned in without using nearly all of the condenser, the loop is entirely too large.

(Continued on page 80)

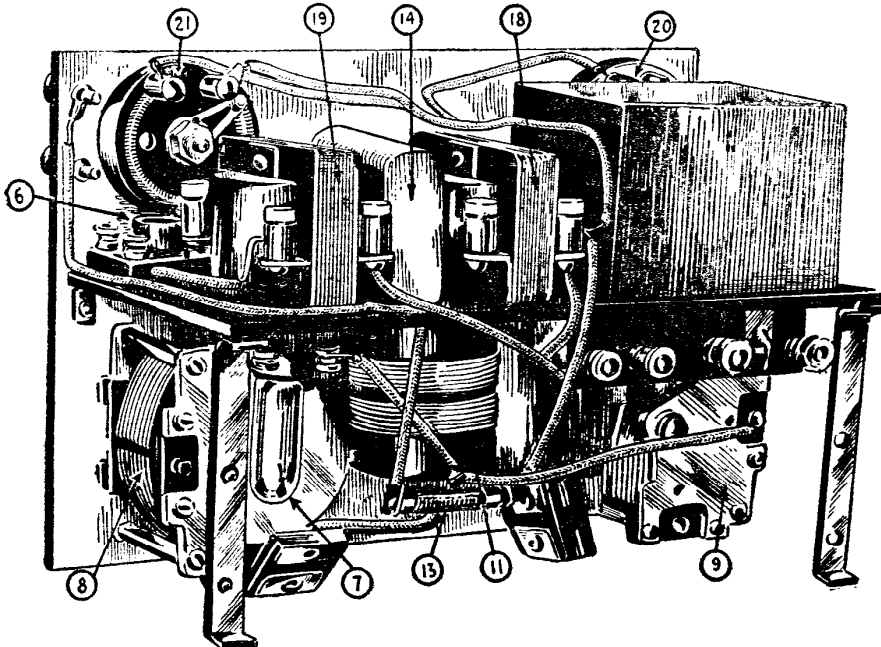

The interior of the receiver is as neat and compact as the outside appearance suggests. It may look a little crowded, but that must be expected after putting seven tubes and the associated apparatus in such a small space.

since the reader may want to use a larger panel or other parts, or may wish to modify his present apparatus along these lines, but a general idea of the layout follows:

The illustrations show front, back and top views of the set. The location of the parts can be easily seen from these illustrations. The front view picture shows two 3-inch dials controlling two .0005 mfd. variable condensers. At this point it may be noted that no condensers having a greater overall diameter than $3\frac{1}{4}$ inches should be used in order to save space. These condensers are mounted 2 inches from the bottom and 2 inches from each end of the panel. A small variable condenser is mounted between the two condensers. The upper part of the panel holds the 10-ohm rheostat, 200-ohm potentiometer and filament switch. They are so placed that the shaft and binding posts will come between two tubes without touching the tubes. The back view above shows this clearly. The filament switch is in the center, at the top.

The top front view shows six small, 1-inch sockets for the "N" tubes mounted on the sub-base next to the panel. The left end of the base holds the 60 kc. intermediate R.F. transformer unit, which is very efficient and compact. Next to the unit can be seen two audio frequency transformers; use the low ratio 3-1. A $4\frac{1}{2}$ -volt "C" battery can be seen between the two transformers.

The back and bottom view shows the tube and socket mounted underneath the sub-base; next to this is the oscillator coupler. This tube is the oscillator tube, and both it and the coupler are placed directly behind the oscillator variable condenser, making the oscillator wiring very short. The grid condenser and leak for the first detector can be seen connected to the spring, supporting the rotor of the oscillator coupler. The two fixed

condensers can be seen lying against the main panel. The other variable condenser serves to tune the loop or antenna coupler. The second detector grid-condenser and leak are mounted underneath the sub-base between the oscillator coupler and the main panel. The picture does not show this.

Assembling the Set

To assemble the set, mount the two variable condensers and the small condensers as low down as possible, especially if 199 tubes are used. Tackle the sub-base next. On one side mount the six tube sockets, as near the edge and as far apart as possible. The 60 K.C. transformer measures $4\frac{1}{4} \times 2\frac{1}{2} \times 2\frac{1}{4}$ inches, and is mounted with the A.F. transform-

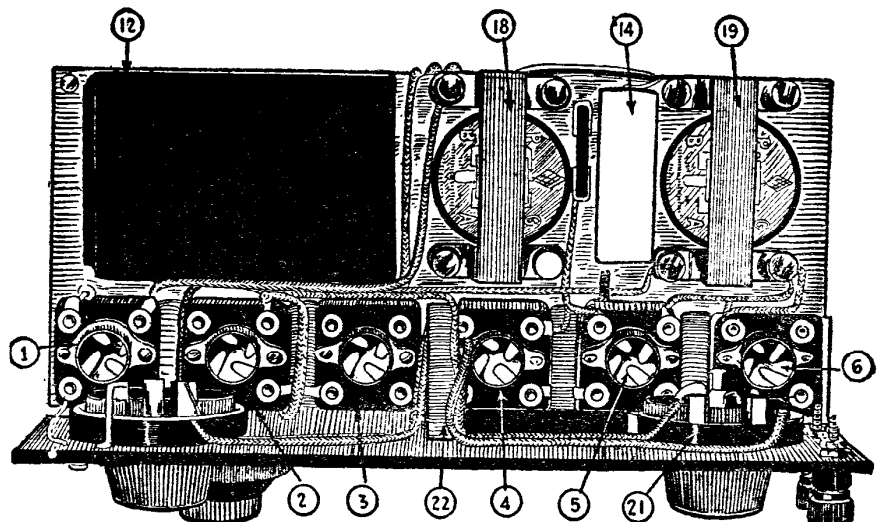

The down-view shows the general arrangement of the apparatus in the receiver above the sub-panel. The numbers are the same as in the wiring diagram.

The Ultradyne Receiver

By ROBERT E. LACAULT, A.M.I.R.E.

The receiver described in this article is a modified Superheterodyne. The improvement made is of such a nature that the sensitiveness is increased and a minimum of controls employed making the set easier to tune. The name "Ultradyne" is merely employed to differentiate this Superheterodyne receiver from those employing the standard circuit. Complete data for the construction of such a receiver is given in the article.

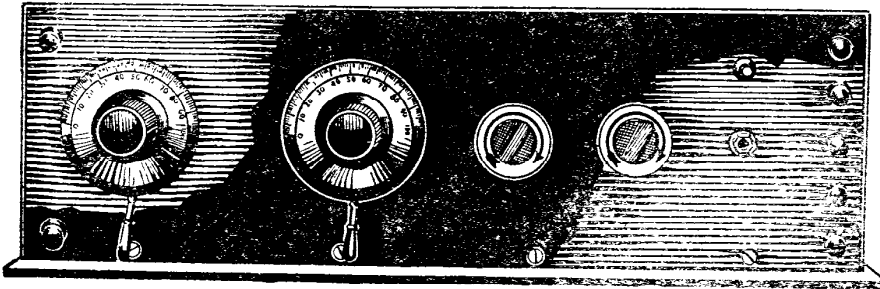

Fig. 3.—Front View of Complete Receiver. The Number of Controls Has Been Reduced to a Minimum, Which Makes the Tuning Easier.

THE Superheterodyne receiver is coming more into use among the amateurs and broadcast listeners on account of its numerous advantages, and it is our intention to describe in this article the construction of a superheterodyne functioning under a new principle. This improved receiver, which has proved superior to the usual type is the result of a long series of experiments carried out by the author. The principle of operation of this receiving system has already been explained in many text books and radio magazines, but we shall describe it again in a few words for the benefit of those who do not have such reference at hand.

Everyone who has operated an ordinary regenerative receiver has noticed that when a broadcast station is being received a whistle is heard in the telephones when regeneration is increased beyond a certain limit. This is caused by the receiver itself, which oscillates and produces, by interference with the

carrier wave of the transmitting station, a beat note of an audible frequency. How beats are produced was very clearly explained by Prof. W. P. Powers in an article which appeared on page 535 of the November, 1923, issue of RADIO NEWS. A beat note has a frequency equal to the difference between the two frequencies which produce it. For instance, if a carrier wave of 1,000 kilocycles is received, a beat note of 1,000 cycles will be heard in the receivers if an alternating current of 999 kilocycles, or 1,001 kilocycles is made to interfere with it. In the Superheterodyne receiver, this principle is employed, but instead of producing beat notes at an audible frequency, beats of a super-audible frequency, such as 50 or 100 kilocycles are used. By means of a variable condenser the oscillator circuit may be tuned so that such a beat note is produced for any incoming signal. Therefore, no matter what the incoming signal frequency is, the signal which is amplified and detected is

always of the same frequency. This is a great advantage because it is easier to design a radio frequency amplifier to function on one frequency only, than one which amplifies in the same proportion a broad band of frequencies.

In most short wave radio frequency amplifiers using untuned transformers, the amplification varies for each frequency. It is generally found that greater amplification is obtained at two points, while comparatively smaller amplification is had over the remainder of the frequency range covered by the transformer. If tuned radio frequency transformers are employed, the tuning becomes very complicated, owing to the numerous controls, and it is difficult to tune in a station unless the entire amplifier is calibrated. The radio frequency amplifier used in the Superheterodyne receiver is designed to amplify at maximum intensity at one frequency only, thus increasing the selectivity, since only signal frequencies which are interfered with by means of the oscillator can pass through the amplifier.

The Modulation System

In the ordinary type of Superheterodyne, the first tube employed as a frequency changer is connected as a detector with a grid condenser and grid leak. This detector rectifies the incoming signal after it has been heterodyned and the variation caused in the plate circuit amplified through a long wave radio frequency amplifier. In the system to be described a new principle is made use of. This system, which has been called the modulation system, causes the incoming signal to modulate the oscillations produced locally in the

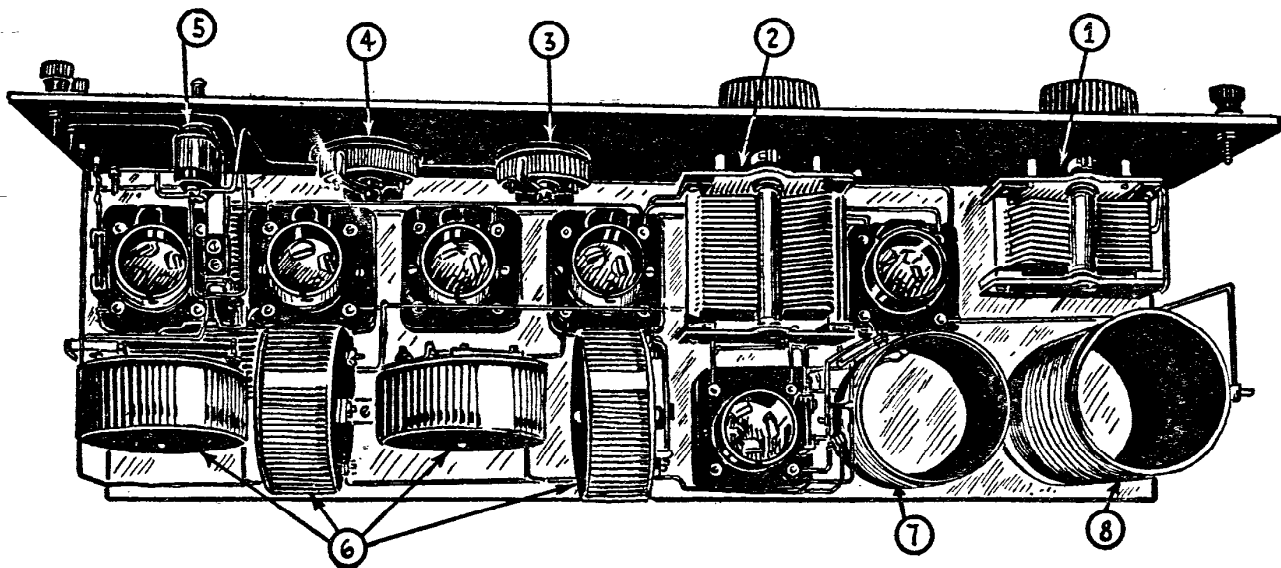

- | | |
|------------------------|-------------------|
| 1 Tuning Condenser | 3 Potentiometer |
| 5 Switch | 7 Oscillator Coi. |
| 2 Oscillator Condenser | 4 Rheostat |
| 6 R.F. Transformers | 8 Tuning Coils |

Fig. 4.—This Top View of the Receiver Shows How the Parts Must Be Mounted to Fit in a 7 x 24-Inch Cabinet.

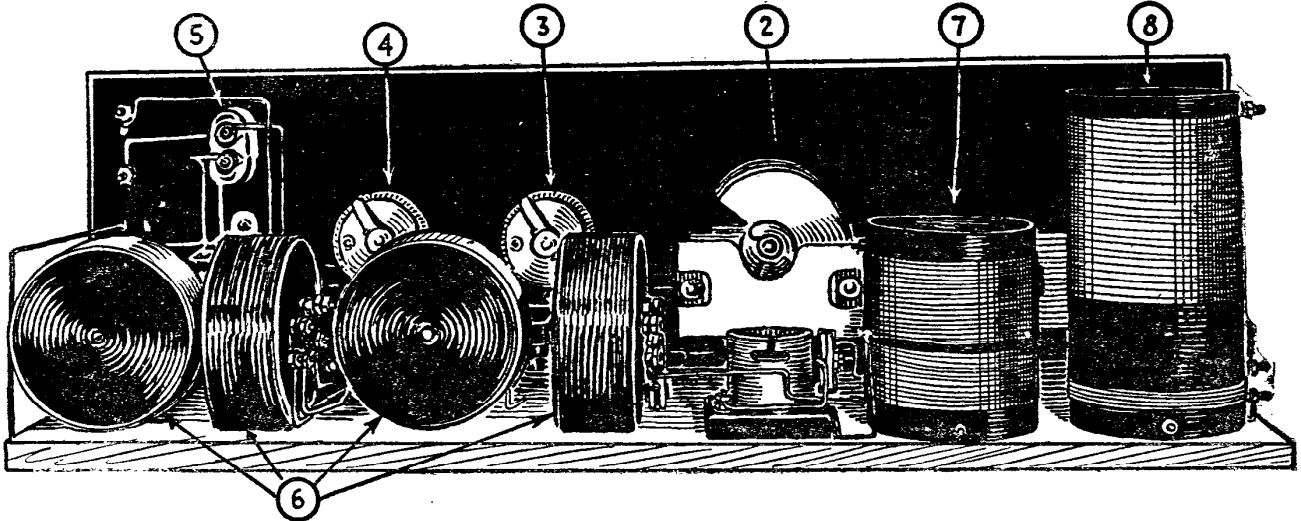

Fig. 5.—Back view of the Ultradyne Receiver. All parts are clearly visible and are numbered to correspond with the top view on page 67. The socket of the oscillator tube may be seen in front of the condenser.

same way that the speech modulates the output of the oscillator tubes in a radio telephone transmitter. This system, which is a departure from the conventional detector arrangement, is not only more simple, but produces a greater signal strength, which is more noticeable on weak signals.

Fig. 1 shows the principle of operation of the circuit. The first tube, which is called the modulator, is connected across the oscillating circuit of the oscillator. The plate-filament space is acting as a resistance, the value of which is varied by the incoming signals impressed upon the grid. In this arrangement no "B" battery is necessary, for the plate of the modulator tube is supplied by high frequency current from the oscillating circuit. To receive continuous waves, this arrangement is very efficient, and it has been applied very successfully to the Superheterodyne receiver described in this article.

To give an idea of the sensitiveness of this receiving arrangement we would mention the results obtained with it in New York City, the set being installed on the fourth floor of an apartment house situated in a good location. Using only the secondary coil composed of 72 turns of wire wound on a tube 3 inches in diameter, stations in Cincinnati, Detroit, Atlanta, Chicago and other cities are heard practically every night with good audibility. No audio frequency amplification is used, and no loop, aerial or ground are connected to the receiver. With one or two stages of audio frequency the loud speaker may be operated and, of course, the music and speech are audible throughout the apartment.

Fig. 2 is a complete diagram of connections of the receiver, while Figs. 3, 4 and 5 are three views of the apparatus completed. The entire outfit may be mounted in a cabinet 7x24 inches, and is composed of the following parts:

- 1 panel 7x24 in.
- 1 cabinet 7x24x7 in. deep
- 1 .001 mfd. variable condenser with vernier
- 1 .005 mfd. variable condenser with or without vernier
- 1 potentiometer
- 1 6-ohm rheostat
- 1 double circuit jack
- 1 battery switch
- 7 binding posts
- 6 sockets
- 4 radio frequency transformers
- 1 .00025 mfd. grid condenser
- 1 .001 mfd. fixed condenser
- 1 grid leak with mountings

- 1 .00025 mfd. fixed condenser
- 1 .005 mfd. fixed condenser
- 1 piece of bakelite, hard rubber or formica tubing 3 in. in diameter and 6 in. long
- 1 piece of the same tubing 3 3/4 in. long
- Bus bar for connections, screws, baseboard 7x23, wire, etc.

The constructional details of the tuning inductance and of the oscillator coil are given in Fig. 6. L1, which is the untuned primary, consists of eight turns of No. 20 D.C.C. wire wound 1/2 inch from the end of the tubing. L2, which constitutes the secondary, is wound with 72 turns of the same wire and 1 1/2 inches away from the primary on the same tubing. The oscillator coil is composed of two sections wound in the same direction as shown in Fig. 6. The first section, L3, connected between the grid and filament of the tube, is composed of 24 turns of No. 20 D.C.C. wire, while the second section, L4, connected between the plates and "B" battery, is wound with 32 turns of the same wire. These coils should be carefully wound and given a light coat of special varnish, which may be obtained from firms manufacturing insulating materials. If no such varnish is obtainable, a light coat of varnish made of acetone, in which celluloid is dissolved, will do very nicely. No shellac should be used on the coils.

It is advisable to fasten the ends of the wire, in each coil, to small screws with nuts fixed on the tubing, as this permits a good connection to be made between the connecting wires and the inductance. The coils may be fastened to the baseboard supporting them by means of small brackets made of brass strips bent at right-angles as shown in Fig. 7C. The ends of the wire in each coil should be soldered to the screws fastened to the tubing in order to insure perfect contact. Once the set is

wired, a drop of solder should also be applied to the joint of the bus bar wire and the screw.

The radio frequency transformers may be of any suitable type designed for long wave reception. Those used in the receiver illustrated in Figs. 4 and 5 are of a special design and may be easily constructed of hard wood or insulating material, such as hard rubber or bakelite. Fig. 7 shows how these transformers are constructed. They may be turned out of a solid piece, or made up of discs of the proper thickness and diameter. The end disc, which is of larger diameter than the others, supports four screws or binding posts, to which are fastened the ends of the primary and secondary windings, and a bracket made of a strip of brass fastened under the screw holding the unit, permits its mounting on the base board. The primary should be wound first and should consist of 500 turns of No. 28 double silk covered wire in the center slot, which is 1/4 inch wide. The secondary is wound in two sections with No. 30 double silk covered wire; 550 turns should be wound in each slot on each side of the primary. The two sections may be wound without breaking the wire by passing it over the primary from one section to the other. To maintain the ends of the wires in place, a drop of sealing wax may be applied on the last turn of both windings. Once the transformers are wound, the screws used as binding posts are fixed on the large disc and the ends of the wire are soldered to them.

The beginning of the primary and secondary windings should go to the positive pole of the "B" battery and center arm of the potentiometer, respectively, while the outside ends of the windings are connected to the plate and grid of the amplifying tubes. In order to reduce the action of one transformer upon

This diagram shows how the modulation method may be employed for the reception of C.W. Signals. This same hook-up is employed in the Superheterodyne described here

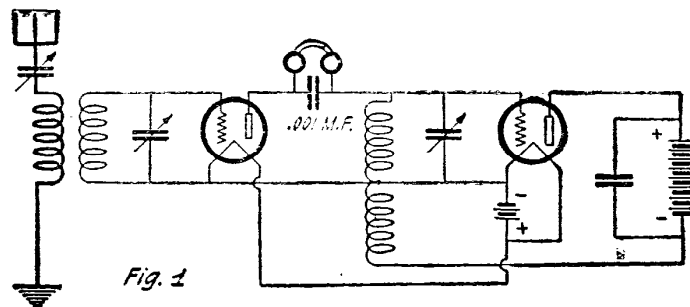

Fig. 1

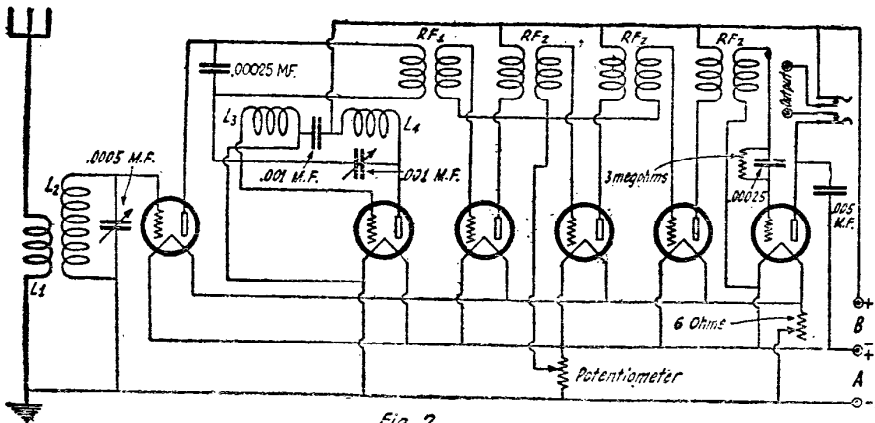

Fig. 2

The complete diagram of connections for the Ultradyne. A double circuit jack or a D.P.D.T. switch may be used to connect the modulator tube to the tuning circuit or loop, if it is desired to use one.

the other, they should be mounted so that their axes are at right-angles to each other, as shown in the illustrations. It should be noted that the primary of the first transformer is wound with only 300 turns, so that its natural frequency is brought up to the same as that of the other transformers when the .00025 M.F. by-pass condenser is connected across it.

The two inside views, Figs. 4 and 5, clearly show the arrangement of the parts on the baseboard supporting the outfit. In order to simplify the wiring of the receiver, it would be advisable to proceed as follows: After the various pieces of apparatus mounted on the panel are fixed, all the wires which are against the panel may be placed and soldered. The sockets, inductances and transformers are then wired separately and the panel fixed to the base. The only connections which remain to be made are those joining the condensers, rheostat, potentiometer and binding posts.

Before mounting the various parts on the panel and baseboard, it is a good precaution to screw tightly all the screws and bolts of the sockets, rheostats and other apparatus, which are very difficult to reach with tools, once they are fixed on the panel or board. We strongly recommend that any amateur attempting to build such a receiver use instruments of good quality, as this is an important factor in the results obtained with a Superheterodyne receiver of this type. The connections should be made with bus bar wire bent at right-angles, or else with No. 16 copper wire, which is cheaper and very efficient for connections.

If a loop aerial is used, the tuning inductance composed of L1 and L2 is not necessary, since the loop is connected across the first condenser in place of the inductance L2. However, it is preferable to use a short antenna, as the signal strength is greatly increased with this type of collector. If no antenna can be installed outdoors, a single wire stretched around a room at a distance of about a foot from the walls and ceiling by means of insulators will be preferable to a loop. The ground connection may be taken on the radiator system, the water pipe, or any other grounded metal-work. If none is available, a counterpoise may be made with a length of lamp cord wound spiral-fashion under the carpet or rug.

The tuning of the Superheterodyne receiver is extremely simple, and in a short time anyone should be able to bring in distant stations, provided the tuning and oscillator condenser are turned very slowly. As the tuning is very sharp, a vernier is necessary on the oscillator condenser, but it may be dispensed with on

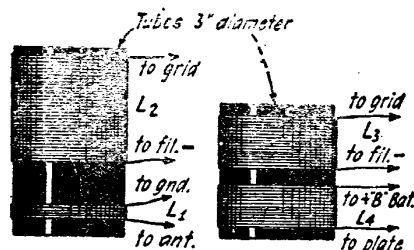

Fig. 6

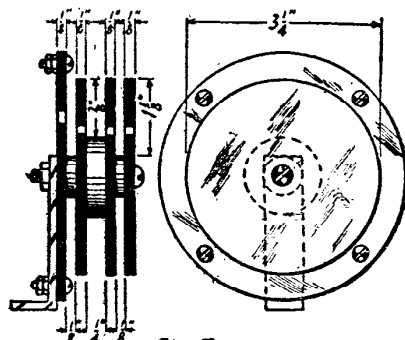

Fig. 7

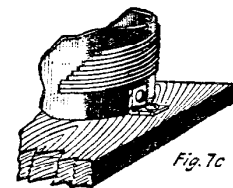

Fig. 7c

Constructional Details of the Coils and Radio Frequency Transformers.

the tuning condenser, which is not so critical in adjustment. The receiver may be calibrated if the same loop or tuning circuit is used at all times, and if desired a silver dial may be employed on the tuning condenser, thus permitting

the inscription of the station call letters to be put directly on it. To tune the receiver, the tuning condenser should be moved two degrees at a time, and the oscillator condenser turned over the whole scale range for each setting of the tuning condenser. Some stations should be heard at one place or another along the scale; if whistles are heard, the potentiometer controlling the radio frequency amplifier should be turned until the whistles stop. The station may the potentiometer may then be adjusted then be brought in loudly and clearly. at the most critical point where amplification is maximum, and need not be re-adjusted unless very weak signals are tuned in. The rheostat acts as a vernier for the potentiometer and sometimes may prove quite useful in bringing to good audibility a distant station. It will be found that signals are heard at two different adjustments of the oscillator condenser. It is therefore best to try the setting which gives loudest signals. After a few hours spent in operating this receiver, it will be quite easy to tune in stations, for at a certain point a slight rushing noise is heard, indicating that a carrier wave is tuned in. From 45 to 90 volts of "B" battery may be used on this receiver. If an audio frequency amplifier is added to operate the loud speaker, it is advisable to use a separate "B" battery on the audio frequency tubes, although the same filament battery may be used. It is recommended to use 201-A or 301-A tubes for the modulator and radio frequency amplifier. A different tube may be used as a detector, although very good results may be obtained with one of the above mentioned tubes, if the proper grid leak resistance is used. For the oscillator we would recommend a 216-A, or E tube (VT-2), although any other tube which operates well as an oscillator may be employed. It is a good idea to try the tubes in different positions, for very often some tubes function better in some stages than in others.

In the second part on the next page the construction of a two-stage audio frequency amplifier to be used with this receiver will be described. Of course, any amplifier is suitable, but this one was designed to match the Ultradyne receiver. We shall also endeavor to give information of value to the amateurs building this receiver, which to date is undoubtedly one of the most sensitive it is possible to build at a reasonable cost.

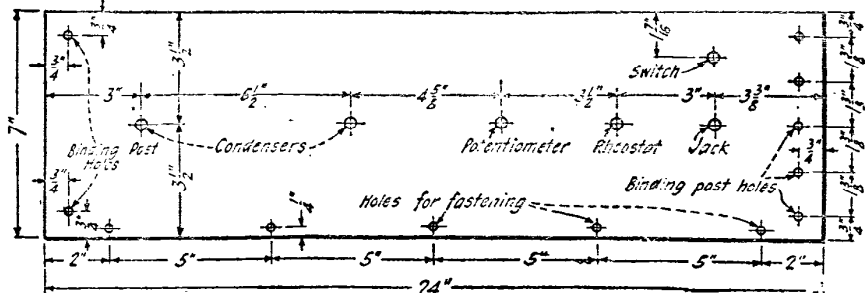

Panel Layout for the Six-Tube Superheterodyne Receiver. A separate audio frequency amplifier should be used, or may be built in by using a larger panel.

The Ultradyne Receiver

By ROBERT E. LACAULT, A.M.I.R.E.

PART II

In the first part of this article, an improved Superheterodyne was described, with which no audio frequency amplification was used. In this article is described a two-step amplifier, especially designed to match the Ultradyne receiver and additional notes on the receiver itself are given.

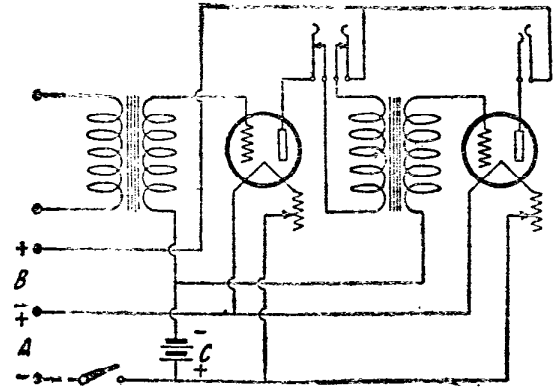
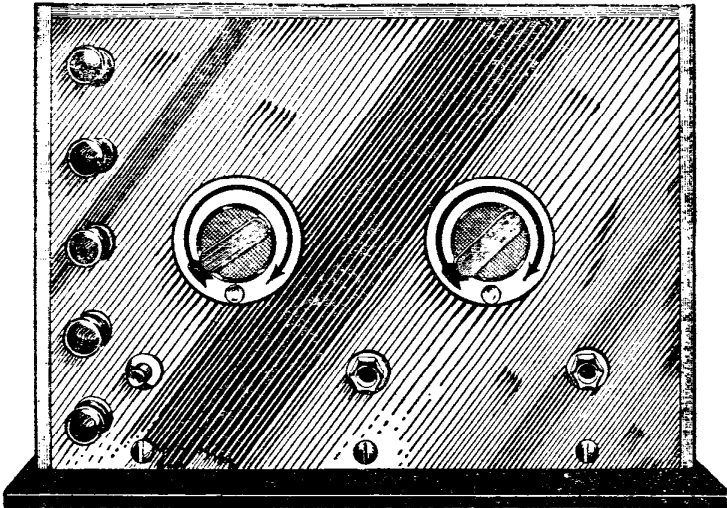

Fig. 6

On the left is a front view of the amplifier and on the right the diagram of connections, with the binding posts arranged in the same order as they are on the panel.

THE two-step audio frequency amplifier described in this article does not present any radical departure from the standard type, and although it is designed to match the Ultradyne receiver, it may be used with any kind of receiver, including crystal sets.

The complete amplifier is built in a cabinet 7x10x7 inches. The 7x10-inch panel is fixed to a wooden base, cut to fit inside of the cabinet, and upon this base are mounted the various parts composing the amplifier. The parts necessary for the construction are: One panel 7x10 inches; one cabinet 7x10 inches; five binding posts; one battery switch; one double circuit jack; one single circuit jack; two rheostats; two sockets; two audio frequency transformers; one 4½-volt flashlight battery; a piece of sheet brass cut as shown in Fig. 5; screws for mounting the parts on the board; and bus-bar wire.

The audio frequency transformers to be used in this amplifier should be bought from a reliable manufacturer and have a ratio of not over 3:1 or 4:1 at the most in order to prevent distortion. A great many amateurs believe that a high ratio transformer should be used in the first stage. This is entirely wrong, as a high ratio transformer distorts speech and music and if the distortion is amplified in the first stage, it is much more marked in the second stage; therefore, the same low ratio transformer should be used in both stages.

The parts used in the construction of the amplifier should be of a good grade and all the following points should be observed when buying them. The rheostats should have the resistance element wound tightly so that the wire does not become loosened after being heated up by the current passing through it. The spring blade sliding over the wire should run smoothly and insure good contact. The screws should be long enough to permit a piece of bus-bar or heavy wire to be screwed tightly under. The sockets should be of substantial construction with enough material to prevent breakage of the part around the slot where the vacuum tube is inserted. The binding

post or terminals should present enough surface to insure a good contact with the connections, and the spring blades pressing against the prongs of the tube should be made of spring brass or phosphor bronze which will not stay bent if once pressed down.

The illustrations clearly show the arrangement of the various instruments on the board and the panel as well as the wiring, which in this particular unit was made with some No. 16 bare copper wire. The flashlight battery is used as a "C" battery to keep the grids of the vacuum tubes at a negative potential. Since this battery does

not deliver any appreciable current, and is not changed often, it was found more practical to mount it inside the cabinet. This battery, if of good make, should last about a year and may be changed when necessary by removing the brass plate holding it in place and unsoldering the two leads connected to the blades of the battery. When connecting the battery, care should be taken that the negative pole is attached to the secondary windings of the transformers. The negative pole of the battery is the one soldered directly to the zinc case of one of the extreme cells. The positive blade of the battery is generally imbedded in the

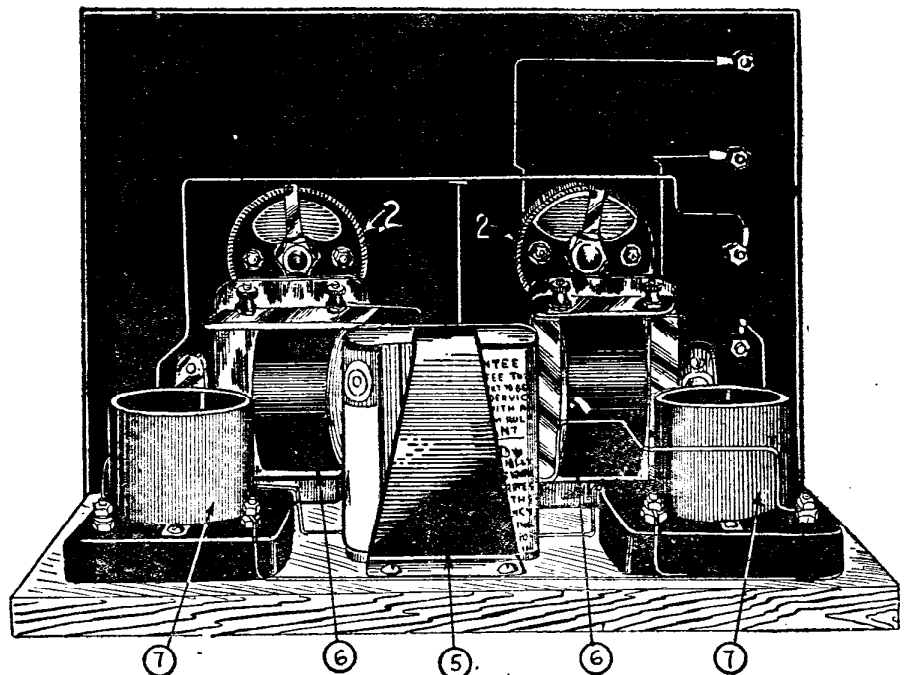

Back view of the amplifier showing the arrangement of parts. No. 2 rheostats, 5 "C" Battery, 6 transformer, 7 socket. Note the wiring and the strip of brass holding the "C" battery.

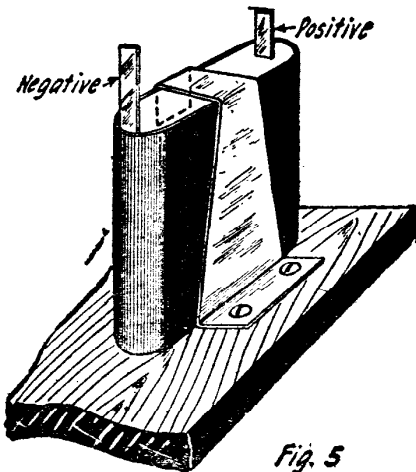

Fig. 5
This sketch shows how to mount the flashlight battery used as a "C" battery and the position of the poles on top of the battery.

sealing wax, while the negative is directly under the wrapping.

Fig. 4 shows the panel layout with the necessary dimensions for drilling the holes which are needed for mounting the binding posts, rheostats, switch and jacks. For the construction after the panel is drilled, one should proceed as follows:

Assembling the Amplifier

First mount on the panel the instruments mentioned above and fix the panel on the wooden base by means of three screws. Second, arrange on the wooden board the transformers, sockets and "C" battery so as to have as much room as possible around them, as this prevents capacity feed-back and makes the wiring easier. After the sockets, transformers and battery are tightly screwed down, the wiring may be done by means of the bus-bar or copper wire which should be bent at right angles, as shown in the illustrations. The two upper binding posts are connected to the primary winding on the left transformer. Care should be taken that the binding post marked P on the transformer is connected to the binding post on the panel corresponding to the one connected to the plate of the detec-

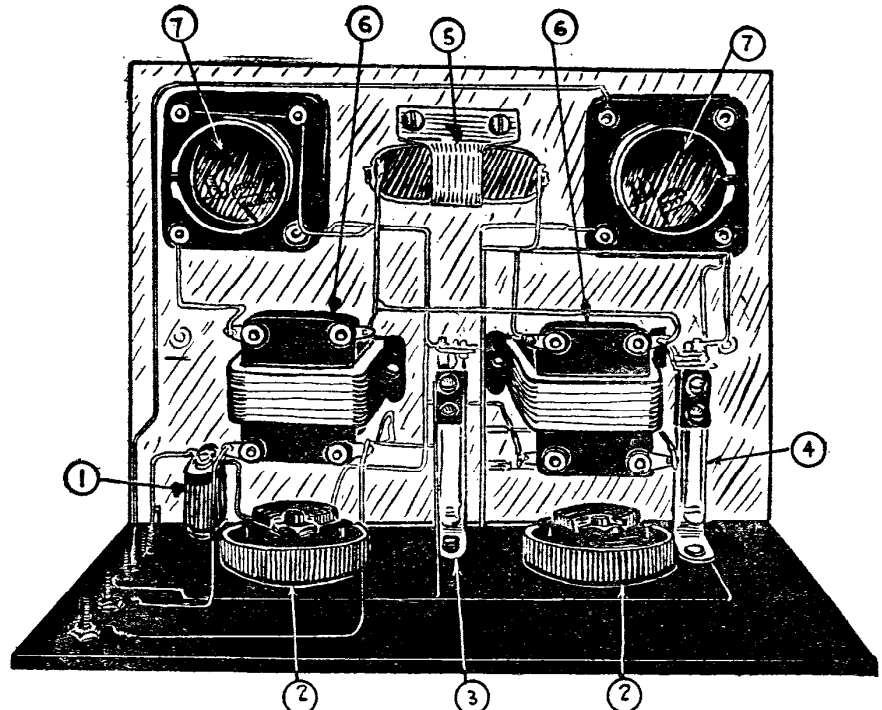

A top view of the two-stage amplifier, showing all the instruments and their respective positions: No. 1, switch; 2, rheostats; 3, double circuit jack; 4, single circuit jack; 5, "C" battery; 6, transformers; 7, sockets.

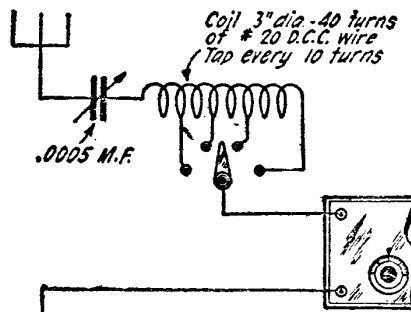

Fig. 7
When using various forms of aerials with the Ultradyne receiver it is sometimes advantageous to follow the above arrangement.

tor tube in the Ultradyne receiver, as this permits the bridging of all binding posts by means of straight pieces of wire. The middle binding post to which the positive of the "B" battery is connected, connects to the two upper blades of the jacks, while the lower ones are connected to the plate terminal on the sockets. The next binding post is the positive "A" battery and is connected directly to the two sockets, while the negative binding post, which is the lowest one, is connected to the battery switch. From the switch, a wire should run to the two rheostats, the other terminals of the rheostats being connected respectively to the two sockets. From the secondary windings of the transformers, leads go to the grid terminals on the sockets, while the other end of the secondary windings are connected together and also to the negative of the "C" battery. From the "C" battery positive, a wire is soldered to the negative of the "A" battery between the switch and the rheostat. The primary of the second transformer is connected to the two middle blades of the double circuit jacks, so that the terminal marked P is connected to the lower intermediate blade of the jack. Of course, all the jacks and joints of the wires should be carefully soldered.

As a precaution before mounting the sockets on the base board, the screws forming binding posts should be tightened with a screw-driver and pliers because it is extremely difficult to reach them once the socket is fixed, and very often a bad contact is formed between the screws and the blade making contact with the tubes.

Notes on the Ultradyne

We have found that a great many fixed condensers now on the market have not the capacity marked on the outside casing, and this may be a source of trouble when operating the receiver described in the last issue. We have tested about a dozen small mica condensers on a standard capacity bridge, and we have found that although the capacity marked was .00025 mfd., their true capacity varied from .0002 to as high as .00052 mfd.

As it is important to use the correct capacity across the first radio frequency (Continued on page 81)

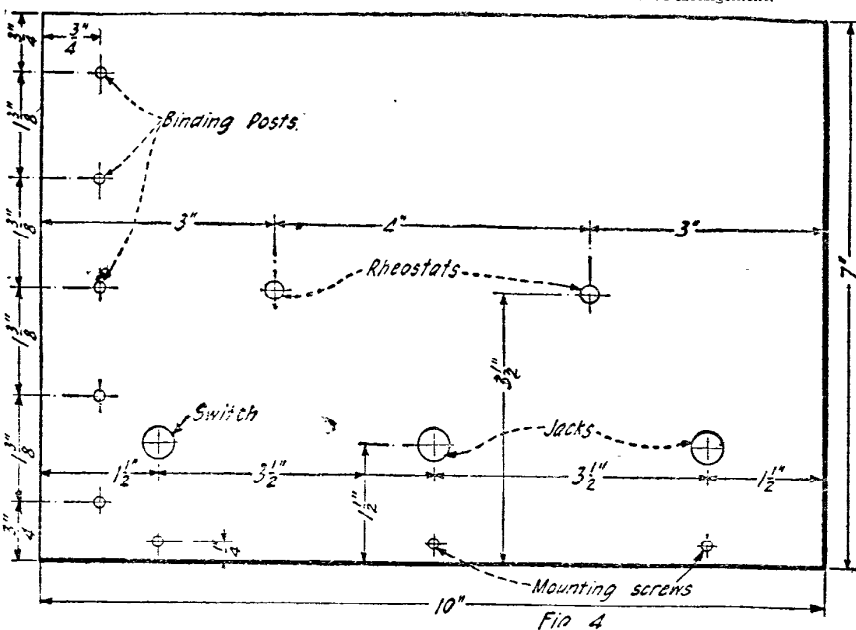

The panel layout for the two-stage audio frequency amplifier. Only the center of each instrument is indicated as the mounting screws are differently spaced for each make of instrument.

Construction of the Ultradyne, L-2

Incorporates New Features in Design

REGENERATION plus modulation is the keystone of the new Model L-2 Ultradyne receiver designed by Robert E. Lacault, formerly radio research engineer with the French Signal Corps. This combination is going to prove as valuable

as easy enough to think up any number of combinations and draw them into an intelligible circuit, but to get the combination to work, and work satisfactorily, is another story and one that is not without its note of despair. Mr. Lacault met up with nu-

ment than was possible with the original type of Ultradyne.

Naturally, the old type single layer cylindrical coils have been replaced by coils of the low loss type. These are the basket weave form and are more compact than the single layer type and decidedly more efficient.

It will be noted from the picture of Fig. 1 that there are few controls. Both the tuning dials are situated in the center of the panel, really the most convenient position for them—right where your hands normally rest. The regeneration control and the potentiometer control are out to either side, being the less important adjusting mediums.

The Layout

The layout is a work of art. Though the size of the panel is the same as in the former model, the instruments are not at all crowded and the leads from instrument to instrument are considerably shorter. It is a fact that it is much easier to wire this set than the old one or sets of similar design. A study of the accompanying illustration will assure one of this.

The panel layout is shown in the picture of Fig. 1. The loop aerial jack is at the extreme left followed by the regeneration control knob, the tuner dial, the oscillator dial and the potentiometer control. The three phone jacks and the "A" battery switch are lined up on the extreme right of the panel.

The circuit diagram is shown in Fig. 4. The units employed from left to right are:

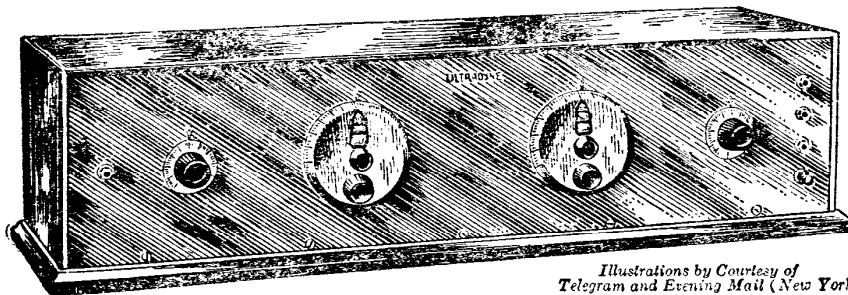

Illustrations by Courtesy of Telegram and Evening Mail (New York)

Fig. 1.—A front view of the new Ultradyne, L-2. Note the convenient arrangement of controls.

to the level minded radio fan as four wheel brakes and balloon tires have to the level minded autoist. There is a strong comparison here, for both the autoist and radio fan seek the same thing—namely, smooth operation and reliable and instant control.

The N. Y. Telegram and Evening Mail Radio Section recently gave account of the constructional details in a most complete way. The article by Hobart S. Sweet reads:

Regeneration plus modulation—you can theorize until you are blue in the face, you can draw conclusions on such a combination from experience with regeneration in conjunction with the usual form of Superheterodyne, but until you experience the performance of the new Ultradyne you don't know the half of it.

But thinking it over from the theoretical standpoint—anyway we know the advantages of the Superheterodyne—maximum amplification for each radio frequency stage for one thing and ease of control for another. Add to this the modulation system, and we make the first detector or frequency changer perform a real service by modulating the oscillations produced by the oscillator tube and thus enormously boost the amplitude of the incoming signal before it ever reaches the long wave radio frequency amplifiers. Now suppose we add the most sensitive and efficient system of amplification known to the radio art: regeneration. To be more exact, suppose we include regeneration in the modulator tube circuit. What is the result? We boost the already boosted incoming signal! There we have it—all the advantages of regeneration. That alone, incorporated in the circuit of a single tube set, puts shades over more elaborate receivers—all the advantages of the modulation system and the Superheterodyne—all in one. Still eight tubes, "but what a whale of a difference," as a cigarette ad states,

As any radio technician will tell you, it

merous difficulties in his attempts to make the combination of regeneration and modulation work to his complete satisfaction, but he was successful in the end.

Specifications

But listen to the specifications of Mr. Lacault's new design—his model L-2—before we cover the constructional details: There are no rheostats. The filaments of all the vacuum tubes are controlled by auto-

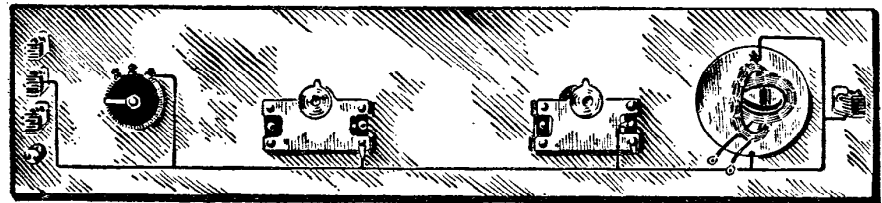

Fig. 2.—The arrangement of condensers, coupler, potentiometer and jacks on the rear of the panel.

matic filament regulating devices. Filament control jacks are employed for the two stages of audio frequency amplification so that it is not necessary to play around with one or a couple of rheostats every time you shift. If you are using both stages of audio and wish to shift to the detector, out comes the plug with your own hands and out go the two audio frequency amplifier tubes without saying boo. Likewise on one or both go when the plug is inserted in one or the other jack.

All binding posts have been moved to the rear, where they rightfully belong, for there should be no wires in front or on the side of the receiver, but behind, where they are out of sight and out of the way. The two variable condensers, of the low loss type, are both of the same capacity, whereas before, one was twice the capacity of the other. Making them both of a capacity of .0005 mfd. provides a more even adjust-

the phone jacks and "A" battery switch, the potentiometer, the 23 plate oscillator condenser, the 23 plate tuning condenser, the regeneration coupler and its copper shield, and the loop aerial jack.

Fig. 3 shows a view of the instruments mounted on the baseboard. The devices similar in appearance to grid leaks are the automatic filament regulators. The oscillator coupler is seen just to the right of the second rear tube socket. The tuning coil is situated to the extreme right of the baseboard. The Ultraformers are seen lined along the front portion of the baseboard in the picture, though this is actually the rear. The "A," "B" and "C" battery binding posts are all mounted on a single strip of bakelite which is supported by two brass columns, and are at the extreme left of the baseboard in the picture. The aerial and ground binding posts are mounted in the same manner and are seen to the extreme right.

Below is given the complete list of parts required for the construction:—

- 1—7x30 inch cabinet with baseboard.
- 1—7x30 inch panel.
- 2—.0005 mfd. low loss variable condensers.
- 2—Vernier knobs and dials.
- 1—Low loss tuning coil.
- 1—Low loss oscillator coil.
- 1—Ultraformer, type A.
- 3—Ultraformers, type B.

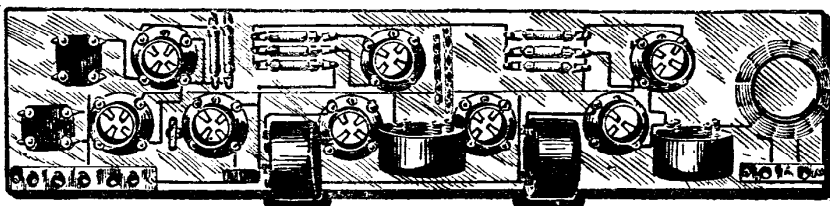

Fig. 3.—View of the parts as they are mounted on the baseboard.

- 1—Low loss 180 degrees coupler with shield.
- 1—Dial for coupler.
- 8—Vacuum tube sockets.
- 1—Dial for potentiometer.
- 8—Amperites, type A.
- 2—Double circuit jacks.
- 1—Single circuit filament control jack.
- 1—Double circuit filament control jack.
- 1—"A" battery switch.
- 2—Audio frequency transformers.

between the "B" and "A" battery connection. If the tube lights in any one or all of the sockets, it is proof that the set has either been incorrectly wired or the "B" battery wires are touching the "A" battery wires at some point. After all instruments and connections have been tested, insert the tubes in the sockets, connect up the "A," "B" and "C" batteries to the proper binding posts, plug in the loop aerial or attach the aerial and

the two condensers for any station. A somewhat similar procedure which will also prove useful is to keep a record of the two dial settings for each station heard. This permits the operator to tune any station which has been already heard by tuning the two condensers to the proper settings. It should be pointed out that the regeneration feature incorporated in the new Model L-2 is a form of radio frequency

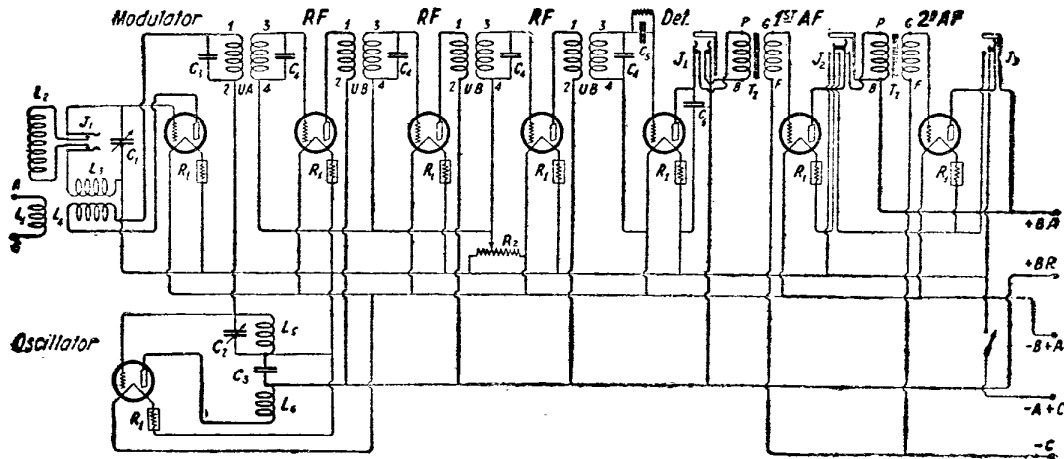

Fig. 4.—The complete wiring diagram of the Ultradyne, L-2.

- 1—Variable grid leak.
 - 7—Binding posts.
 - 2—Bakelite binding post mounting strips.
 - 1—.0005 mfd. condenser with grid leak mounting.
 - 4—.00025 mfd. fixed condensers.
 - 2—.001 mfd. fixed condensers.
 - 1—.005 mfd. fixed condenser.
 - No. 14 tinned copper bus bar wire.
 - Assortment of screws and nuts.
 - 1—400 ohm potentiometer.
- Above all means purchase the best of materials. The L-2 Ultradyne is worthy of the best, and if full service is to be expected do not use any inferior parts.

Assembling the Receiver

The first job to be done is the panel drilling and the mounting of the phone jacks, "A" battery switch, the two 23-plate variable condensers, the potentiometer and the coupler and shield, Fig. 2. Lay out the baseboard next, placing each instrument in its proper position as shown in the picture of Fig. 3. The complete circuit diagram is shown in Fig. 4. Wire the instruments mounted on the panel first, then the instruments on the baseboard. Be sure and solder all connections and take your time about it to insure a good job. Be sparing with the soldering flux and use a hot iron. After both the panel and baseboard instruments have been wired, attach the baseboard to the panel and complete the wiring between the instruments on each.

Be sure and check all the connections when you have completed the wiring and as a final check-up test each soldered joint with the battery and headphones to insure perfect electrical contact. As a precaution before operating the set, connect your "A" battery to the "B" battery binding posts and with one tube test each and every tube socket to be positive that there is no short

ground and, with the phones or loud speaker plugged in, pull the filament switch.

The following is the correct procedure for tuning in:—Turn the oscillator dial one degree at a time and for each setting of this dial turn the tuning dial slowly through its whole range. If nothing is heard at any setting, move the oscillator dial one more degree and repeat the process with the tuning dial. At some point one should hear a station, and it will be noticed that a slight hissing noise is heard when the station is transmitting, but no speaking or singing into the microphone. The slight hissing noise indicates the presence of a carrier wave and will help materially in tuning in the various broadcast stations. All this tuning should be done with the potentiometer adjusted to a point where no whistles are heard. If whistling noises are present, the potentiometer should be turned toward the positive side until the whistling stops, at which point the amplifier operates at its maximum sensitiveness.

When tuning in distant stations, it may be necessary to readjust the potentiometer slightly. This should be done only after the station is heard faintly, but clearly enough to increase the amplification. When tuning in very weak signals the feed-back or regenerative coupler should be turned slowly until a point is reached where a whistle is heard, then moved back just below this point. A slight readjustment of the two condensers will then bring the signal to maximum audibility. When tuning in another station, turn the feed back coupler to zero (coils at right angle) and tune first with the two condensers, as explained above, then adjust the coupler once the station is tuned in.

If the same antenna or loop be used at all times, the set may be calibrated and a curve made giving the proper settings of

amplification and consequently plays its most important part when you are receiving a long distance station. Its use does not increase the volume of the signals received from the local stations to any appreciable extent, this not being the object, as greater volume can always be obtained by the addition of audio frequency amplification. But it does increase the volume of stations at a distance for the reason that the weak signals are boosted in amplitude before they pass through the long wave radio frequency amplifier. Since the object of the regeneration feature is to make the Ultradyne more sensitive to weak signals, it should be evident that it will increase the volume of signals from distant stations that could not be heard on an Ultradyne without regeneration.

As has been said, no great difference will be noticed in the volume of local stations, but it is surprising what the regenerative feature does in connection with the reception of long distance stations. Probably the most advantageous point is that it insures reliable and consistent reception from stations that heretofore faded or swung badly, and this is exactly what is desirable in a receiving set.

With the addition of regeneration, it will be found that the second stage of audio frequency amplification is of real use only when receiving from a very distant station. All the volume desired is had with one stage of audio frequency amplification when receiving local or semi-local stations. The second stage of audio frequency amplification, however, is quite desirable for long distance work and may be likened to a high powered car when, under normal conditions, the surplus power is not used, but it is there for use in case of emergency. It is always nice to know that you have it to use when you wish.

A Noiseless Intermediate Amplifier

BY G. C. B. ROWE

The present amplifier will be found exceptionally valuable on account of its characteristics which tend to cut out the noise and at the same time increase the selectivity of the complete set.

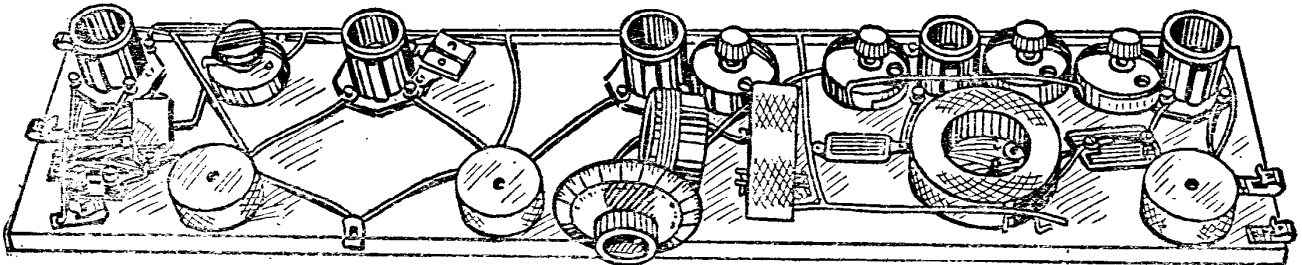

Above is a view of the laboratory layout of the new interference eliminating amplifier. Note that the apparatus is assembled on a base-board in a rather haphazard manner. It was built for experimental purposes only, with no attempt to design a finished model. The five sockets shown are for the four tube intermediate amplifier and second detector.

WITH the advent of summer time, the bug-bear of static and atmospheric noises comes to the fore again. The users of the Superheterodyne are confronted with this nuisance more than the same listeners with other types of sets, since the intermediate frequency amplifier employed in it tends to pass more miscellaneous noise than straight tuned radio frequency sets or those of the single circuit class on account of the low frequency to which the intermediate stages are tuned.

The principle involved is simple in the extreme, being a combination of resistance coupling amplification with the addition of a sort of trap circuit in the form of a tuned circuit placed across the connections between the separate stages working in conjunction with the resistance coupled amplifier.

With the addition of small value blocking condensers in the grid and plate circuits, two of the tubes function as detectors on the low frequencies, those in the audio range, while giving intermediate frequency amplification to the desired signal. Through this process of elimination, practically every wave-length but the one desired is cut out before the signal reaches the second detector and the audio frequency stages.

By referring to Fig. 1, the action of the circuit may be easily explained. The first detector and oscillator are of the standard type. No deviation from the regular Superheterodyne hook-up is noticed until the first tube of the intermediate frequency is reached. A standard trans-

former is connected between the first detector and the first intermediate frequency tube. The grid circuit of this tube functions in the standard fashion.

In the plate circuit, however, the connections are changed. Instead of the intermediate frequency transformer, there is a resistance, a tuned circuit and a grid leak. The action of this circuit may be easily explained.

The heterodyned signal delivered to the plate circuit of the first detector is passed through the transformer PS to the grid circuit of the first intermediate frequency amplifying tube. Here it is again amplified. It is well to note that everything passing the first detector is also amplified to some extent. This includes static, atmospheric noises, other signals than the one desired on account of the broadness in tuning of the tuned grid circuit of the first tube, and a certain amount of extraneous noise arising from the transformers, the tubes and the oscillator.

All this noise is amplified, but the nature of the coupling between the first amplifier and the second tends to reduce it in the following manner: The condensers C1 and C2 are of small capacity, .00025 mfd. or less. Experience will show that the static and tube noises are of audio frequency and are usually loud in ratio to the signal intensity. Therefore, the size of C2 effectually prohibits their passage onto the grid of the next tube. The only possibility left to them is to take the alternative path through the resistance R1, which is ap-

proximately of 25,000 ohms value. Here they are dissipated in the form of heat, leaving only the higher frequencies to pass on.

Now the desired signal at the intermediate frequency, in this case 6,000 meters, passes through the small condenser with relative ease and travels on its way toward the grid of the next amplifier. And here is where the trap circuit L1 C4 comes in. This circuit is tuned exactly to the intermediate frequency by the cut and try method, i.e., using a small variable condenser or else adding or subtracting turns from the inductance. When the signal reaches this point, with the oscillatory circuit tuned exactly to the intermediate frequency, all that part of it which is not in resonance with the trap circuit dissipates itself by following the inductance to the grid return.

However, since the trap circuit is tuned exactly to the intermediate frequency which it is desired to pass, an infinite resistance is created and the desired signal prefers rather to travel on toward the grid of the next tube. Thus it is seen that all the extraneous currents traveling along with the signal on account of the broadness in tuning of the first circuit or due to other causes, are eliminated, thus making the set much more selective.

The same line of action is repeated in the second resistance stage. The last two are of the usual transformer coupled type and are standard in every way. These are followed by the second detector and two audio stages.

(Continued on page 81)

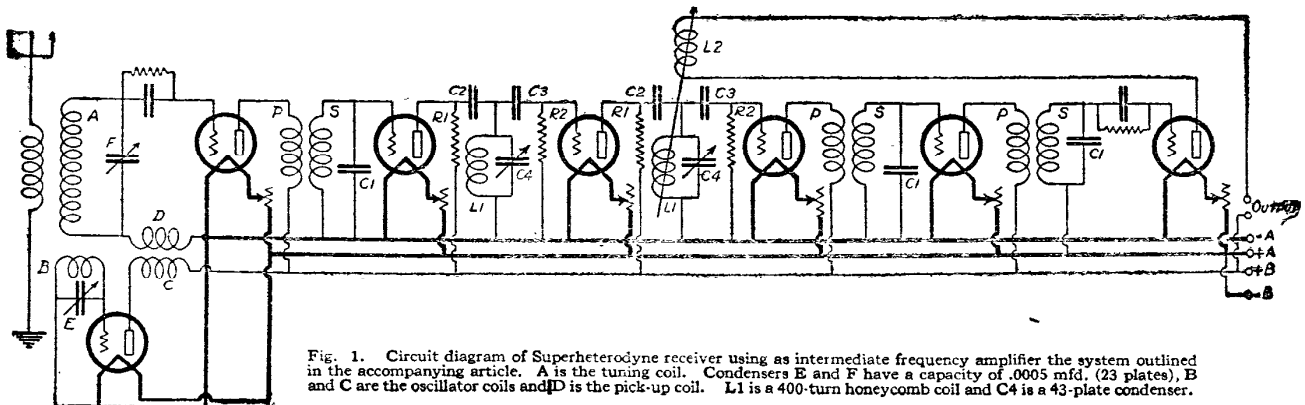
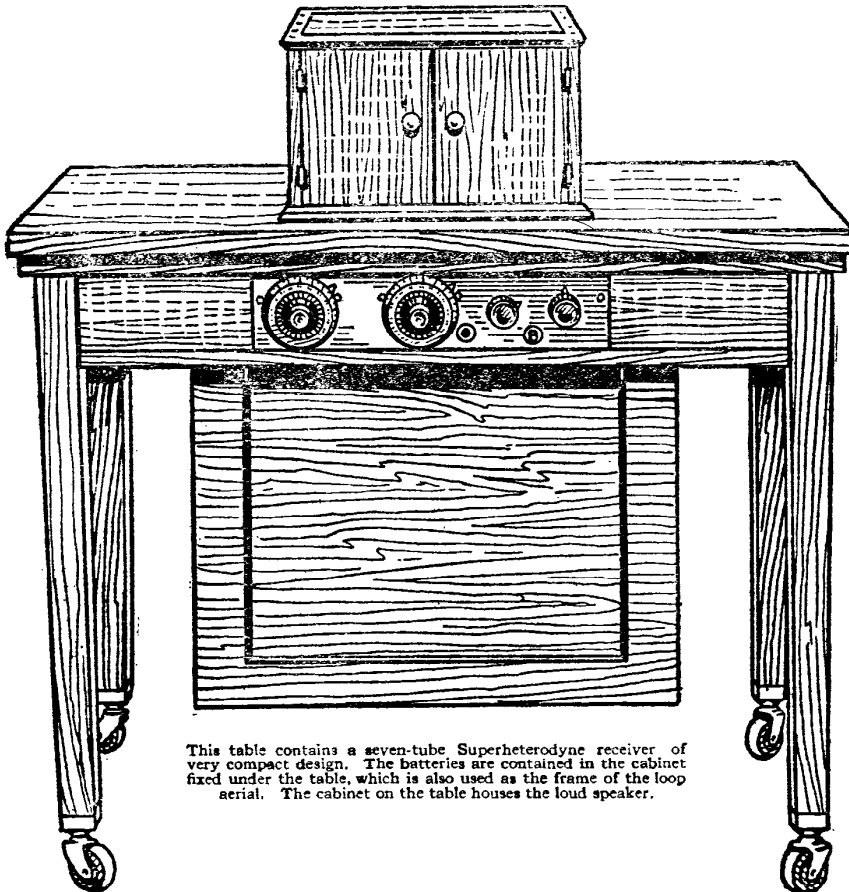

Fig. 1. Circuit diagram of Superheterodyne receiver using as intermediate frequency amplifier the system outlined in the accompanying article. A is the tuning coil. Condensers E and F have a capacity of .0005 mfd. (23 plates), B and C are the oscillator coils and D is the pick-up coil. L1 is a 400-turn honeycomb coil and C4 is a 43-plate condenser.

Putting the Superheterodyne on Wheels

BY S. R. WINTERS

A Superheterodyne of novel design embodying several interesting features which might be adapted to similar and other receivers.



This table contains a seven-tube Superheterodyne receiver of very compact design. The batteries are contained in the cabinet fixed under the table, which is also used as the frame of the loop aerial. The cabinet on the table houses the loud speaker.

MOUNTED on serviceable castors, with rubber tires, a radio receiving outfit of the Superheterodyne model was recently installed in the lounge room of the Racquet Club, Washington, D. C. Although home-made, this equipment harmonizes with furniture of any type or period and the radio instruments are so cleverly disguised that when locked in their container there is little indication of the presence of vacuum tubes, transformers, condensers, a loop antenna and a loud-speaking unit.

The principle of the Superheterodyne circuit is faithfully copied in the equipment. The designer, "Barney" Foy, a radio amateur, demonstrated originality and no little ingenuity in the distribution and balancing of the parts entering into the construction, in the reduction of wires to a minimum, and in the building of a cabinet resembling a piece of furniture.

The space required for this Superheterodyne receiver is about equal to that allotted to a Neutrodyne set. The

amount of wire used is only one-twentieth of that ordinarily employed in such elaborate radio receiving equipment. Only five lengths of bus bar, approximately 120 inches, are utilized in connecting the eight vacuum tubes, transformers, condensers, and other working parts. In fact, in glancing at the outfit from the top, there is a conspicuous absence of wiring.

The instruments are placed on panels similar to the construction of the sub-chassis of an automobile—that is, they occupy a minimum amount of space in the interest of simplicity. Thus, in event of a short circuit or other wiring trouble, the wires are readily exposed and a checking of connections is facilitated to that extent. All of the wires are soldered to lug terminals thereby insuring absolute contacts without resorting to soldering of the fittings—a practice all too prevalent, and one that is likely to impair the service of the various parts.

Audio frequency amplification in this instance is restricted to one stage. Con-

trary to ordinary practice, four instead of three intermediate stages of radio frequency amplification are employed, in addition to the usual input transformer. This departure, however, affords almost as great a degree of amplification as if two stages of audio frequency were invoked. This relatively great amount of radio frequency amplification is resorted to without producing distortion.

The loop antenna used with this set is 23 inches square, and is comprised of 15 turns of Litz wire, each turn being spaced three-fourths of an inch from the next one. Contrary to customary procedure, space is reserved in the battery compartment for operating this loop. The arrangement functions well.

One of the chief advantages of this set lies in the fact that it is foolproof. That is to say, lock and key may be applied to prevent inexperienced operators tampering with the apparatus. Withdrawal of the key that locks the cabinet cuts off, automatically, the battery current. The possibility of an inexperienced operator burning out several tubes is thus averted.

Reception of radio signals, despite interference from violet-ray machines and other electrical equipment, includes programs from stations located in Denver, Davenport, Jefferson City, Mo., Chicago, New York, Providence, and Atlanta. These reception tests involved the use of a 24-inch loop antenna, with no connection to the ground.

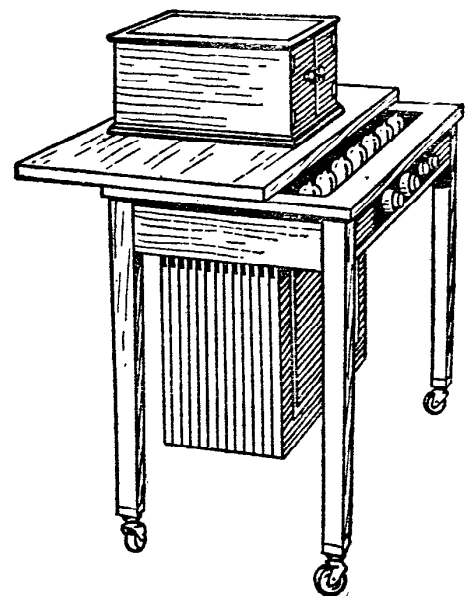

Side view of the set showing the loop aerial and the sliding top of the table. Note the seven tubes.

Data on the New Pressley Superheterodyne

SINCE the introduction of the new seven-tube, non-radiating receiver developed by Mr. Jackson H. Pressley, chief engineer of the Radio Laboratory at Camp Alfred Vail, N. J., so much interest has been aroused in this circuit

constant annoyance. When the receiver has been properly balanced it will tune as quietly as a well balanced neutrodyne receiver, and no squeals or howls can be heard except those due to outside causes. For the same reason the quality is excellent, and

The Bridge System

Fig. 1 shows how the bridge scheme is used in the Pressley receiver as a portion of the oscillating detector circuit. The two inductances, L1 and L2, are really one coil tapped at the center (point "B"). The condenser C0 is the oscillator tuning condenser, by means of which frequency may be varied. Coil LT is the tickler coil, rigidly coupled to L1 and L2 so as to maintain oscillation in the bridge circuit. A balance is obtained in this circuit by adjustment of one or the other of the condensers C1 or C2, these two condensers being combined into one by the use of a split stator condenser. At this condition of balance no voltage will exist between the points "B" and "D," due to the oscillations of the tube. This prevents radiation from the loop.

If a perfect balance of the circuit could be obtained there would be absolutely no current in the loop circuit due to the oscillations of the tube. This, however, is not exactly the case. In wiring a receiver of this sort there is always a certain amount of coupling between the wires leading to the loop circuit and the wires connecting the different apparatus used in the bridge circuit, and the two circuits are thereby coupled together, however slightly, even when the bridge itself has been balanced. There might also be a certain amount of coupling between the loop and the oscillator coil, although this coupling is extremely small because the dimensions of the oscillator coil are as small as possible.

For these reasons the voltage across the points "B" and "D" can never be reduced to zero. In spite of the fact that the bridge can never be perfectly balanced, it can always be sufficiently balanced to prevent any appreciable amount of radiation from the loop, and also to prevent the presence of squeals and howls due to heterodyne action when receiving a station.

If the lay-out of the apparatus is exactly the same as that described in this article, an almost perfect balance can be obtained in the bridge circuit. The author wishes to point out the fact that it is important for the man who builds his own receiver to follow precisely the lay-out of apparatus, the selection of parts and the wiring diagram specified. This type of receiver, while very much less critical than the ordinary type of Superheterodyne receiver, nevertheless requires some care in building and wiring to insure good results. In the author's experience more trouble has resulted by arranging the parts of a receiver to suit the builder's own fancy than from any other cause. Some builders never stop to realize that the arrangement of the apparatus is just as important in such cir-

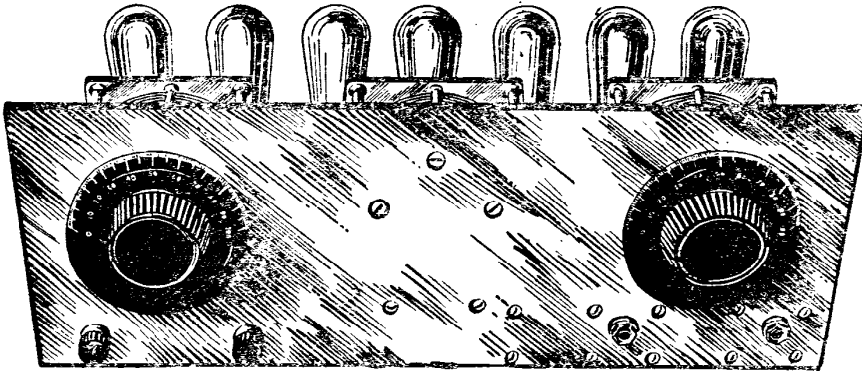

Illustrations by Courtesy of N. Y. Herald-Tribune

A front view of the Pressley Super-Heterodyne showing the new arrangement of controls.

that it would not be out of place to give complete information regarding the construction and balancing of this receiver.

In a recent issue of *The New York Herald-Tribune Radio Magazine*, this data was given by Frank W. McDonell as follows:

While primarily designed by the army for airplane use, this receiver is admirably adapted to the use of broadcasting listeners. Through the co-operation of a number of manufacturers of reliable radio apparatus, the essential parts used in this receiver have been made available to the general public for the construction of a similar receiver suitable for broadcast reception.

Two Salient Features

There are two salient features of this receiver: the bridge balanced oscillating detector circuit, which prevents radiation from the loop, and the unusually fine design and construction of the intermediate frequency transformers.

The first of these features is based upon the principle of the Wheatstone bridge, well known among most radio experimenters. For a theoretical discussion of the application of this scheme to the Pressley circuit the reader is referred to the article by Captain Paul S. Edwards in *The New York Herald-Tribune* of November 23, 1924.

The other salient feature of the Pressley receiver is the design of the intermediate frequency transformer. In most Superheterodyne receivers the efficiency of the intermediate frequency amplifier depends upon the use of a certain amount of regeneration in the amplifying circuits. This regeneration is ordinarily controlled by a potentiometer, and unless the operator has acquired a certain amount of skill in using the receiver the background of noise in the loud speaker will be extremely objectionable because of the presence of regeneration in the intermediate frequency amplifier.

In the Pressley circuit the intermediate frequency transformers have been so cleverly designed that they do not depend upon regeneration for amplification. No potentiometer or other control is necessary to adjust the amplifier for maximum efficiency. The rheostat controlling the intermediate frequency amplifier tubes is used solely as a volume control, and the adjustment of this rheostat is in no way critical.

These features make the tuning of the Pressley receiver a pleasure rather than a

background of objectionable noises is reduced to a minimum.

An additional advantage of the Pressley receiver lies in the fact that while only one tube is used to perform the function ordinarily performed by two tubes (that of first detector and oscillator) in the stand-

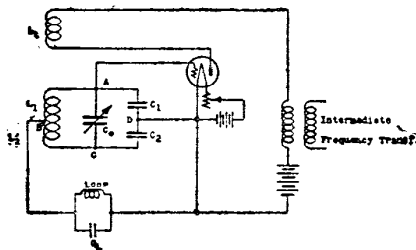
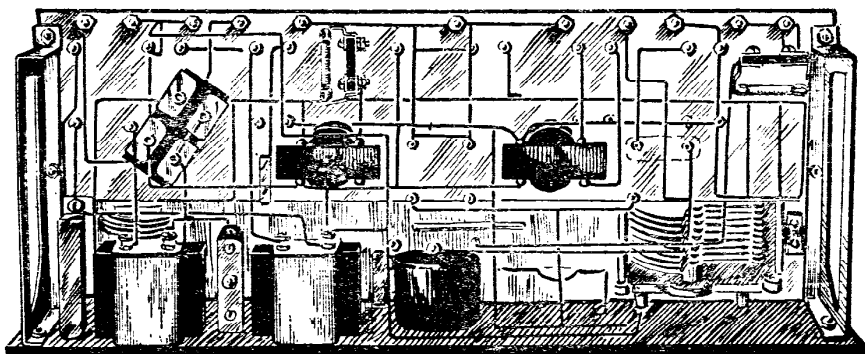

Fig. 1. Diagram of the bridge scheme used in the Pressley Super-Heterodyne.

ard Superheterodyne circuit, nevertheless this one tube is actually more efficient than the two tubes as used in the standard Superheterodyne circuit.

Many builders of this receiver seem to have experienced trouble in securing a proper balance of the bridge circuit. This balance can be very easily obtained if the builder follows the circuit specifications implicitly.



How the Pressley set appears from a bottom view. Neatness in the wiring of parts is an outstanding factor.

cuits as the use of the correct wiring diagram, and very often they throw away months of careful development along these lines by prominent engineers simply to satisfy their own idea of panel lay-out, etc. The illustrations accompanying this article show the arrangement suggested.

Balancing the Detector

To balance the detector circuit connect a pair of telephones in the B battery lead to the first or oscillating detector tube. The loop should remain connected to the receiver, with the wave change switch thrown to the short-wave side, and all batteries should be connected. It is not necessary, however, that any except the first tube be placed in the sockets. Test the circuit to make sure that it is oscillating by wetting your finger and putting it on the grid binding post of the socket. If a click is heard in the telephones as you touch the grid binding post, and another as you remove your finger from the grid binding post, the tube is oscillating. This test may be re-

time vary slightly the position of the rotor of the split condenser until the clicks entirely disappear, or at least become as faint as possible. The loudness of the clicks heard will depend largely on how rapidly the loop tuner dial is moved back and forth. Even if the loop condenser dial is moved quite rapidly there should be no more than a very dull thud in the telephones when the circuit is properly balanced. Having once achieved this condition of balance, the split condenser may be locked in position by the set screw provided for that purpose, and thereafter need not be changed.

Of all the Pressley receivers which have been sent to the author's laboratory with the complaint that they could not be balanced, there has not yet been one case in which the receiver could not be balanced if the circuit was correctly wired and if there were no open circuits or short circuits present. If it is apparently impossible to balance the circuit by the method outlined wiring of the bridge circuit and the con-

- One "X" Laboratories 15-ohm rheostat.
- One Benjamin seven-tube gang shelf.
- One Benjamin grid leak panel.
- One Benjamin battery switch.
- One pair Benjamin brackets.
- One Thordarson 6:1 audio transformer, first step.
- One Thordarson 2:1 audio transformer, second step.
- One Patent double circuit jack, No. 63, first step.
- One Patent single circuit fil. control, No. 65, second step.
- Two Dubilier .00015-mfd. micadons, type 601-G.
- One Dubilier .005-mfd. micadons, type 601.
- One Dubilier .5-mfd. micadons, type 656.
- One 1/4 megohm grid leak (first tube detector and oscillator).
- One two megohm grid leak (second detector).
- One jack switch Carter No. 3 or Yaxley No. 30).
- One loop (Portena or Marion).

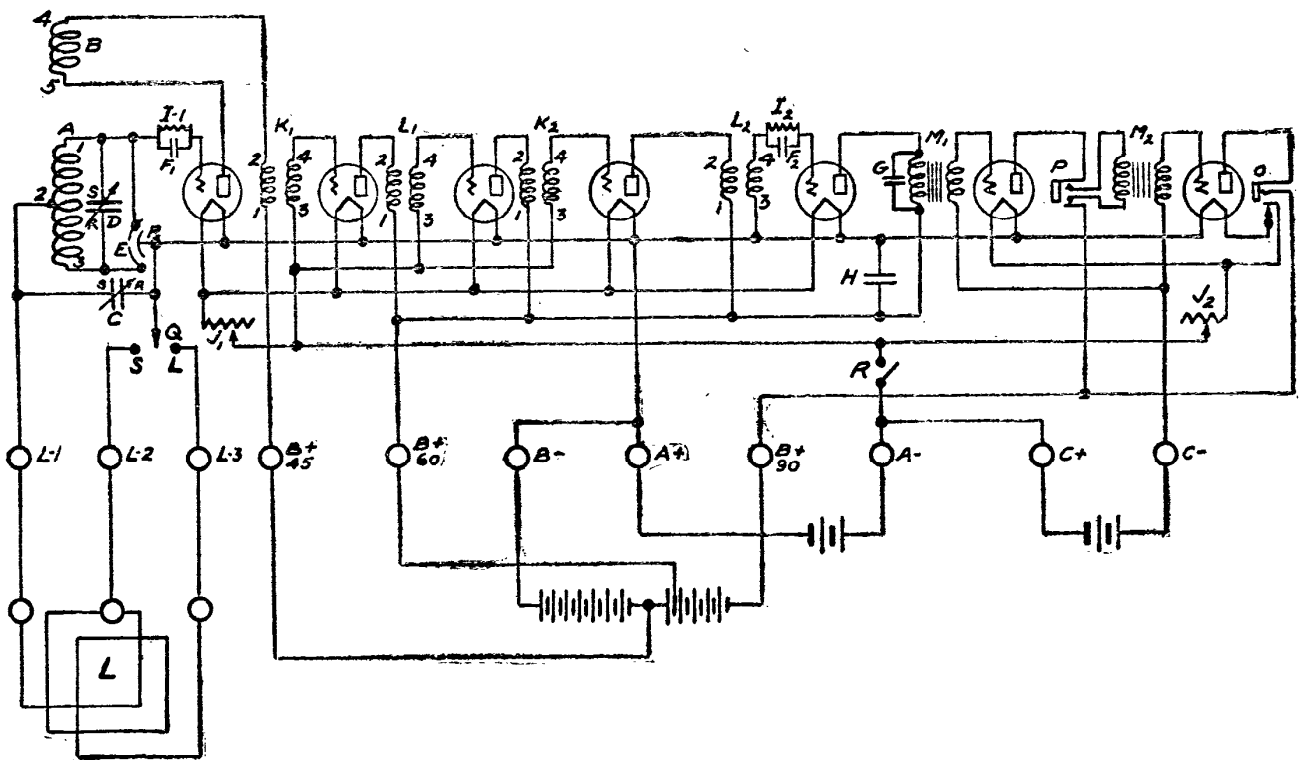

Fig. 2. The wiring diagram of the new Pressley Superheterodyne.

peated with the oscillator condenser dial placed at different points over the scale to make sure that the tube oscillates equally well at any position of the tuning condenser dial. When you are sure the oscillator functions properly set the oscillator dial at about forty divisions of the scale or at some point near forty divisions where you cannot hear any whistles or signals which might be received from a powerful local broadcasting station. Then, leaving the oscillator dial set at this point, move the left hand or loop condenser dial over the scale.

If the dial is moved over the scale rather rapidly a click will be heard in the phones. This click is due to a transfer of current from the oscillator circuit to the loop circuit. If the bridge is properly balanced there will be no such transfer of current from one circuit to the other and we will hear no such click. To balance the bridge continue to rotate the loop tuning condenser back and forth rather rapidly over that portion of the dial at which the clicks are heard in the telephones. At the same

nections in this circuit should be checked very carefully.

The complete parts for this receiver may be purchased from any reliable radio dealer. All of these parts listed below have been selected with a view of increasing the efficiency of the receiver as far as possible, as well as providing smooth mechanical controls for the moving parts, such as the condensers and rheostats. The list of parts in the receiver shown in the photograph is as follows:

Parts Required

- One 7x18-inch Bakelite panel, drilled and engraved.
- One Sangamo kit, consisting of one oscillator coil, two iron core and two air core transformers.
- One "X" Laboratories, .00007-mf. balancing condenser.
- One "X" Laboratories .0005-mfd. Vernier condenser.
- One "X" Laboratories .0005-mfd. plain condenser.
- One "X" Laboratories dial to match.
- One "X" Laboratories 6-ohm rheostat.

The following directions, if followed in the assembly and wiring of this circuit, will be found extremely helpful:

1. Attach brackets to socket shelf.
2. Attach iron and air core transformers to bottom of socket shelf, as shown in the accompanying illustration. The air core transformers should be mounted so that the terminals 1 and 3 are nearest the front panel; the iron core transformers so that the terminals 1 and 2 are nearest the front panel.
3. Mount grid condenser panel on left socket shelf bracket.
4. Run a solid bus as close to the shelf as possible, connecting the positive filaments of the first six tubes. (The seventh tube is connected through the filament control jack).
5. Run a solid bus connecting the negative filaments of the first five tubes together (later to be carried to the six-ohm rheostat).
6. Connect the negative filaments of the last two tubes together (later to be carried to the 15-ohm rheostat).

(Continued on page 81)

Matching Tubes for Superheterodyne

BY S. YOUNG WHITE

THE question among Superheterodyne builders at the present time seems to be, "Why does my set give so much better (or poorer) results than my friend's, when we both have the best of parts?" The mystery is further complicated by the fact that the good and indifferent models may be exact duplicates, built of similar apparatus furnished by the same manufacturer. Since these are factory products, we may assume that the great variation in results is not all due to their lack of uniformity. The experience of the writer would indicate that the most serious obstacle encountered by the average builder of this circuit lies in his inability to match the tubes in the set so they work together in perfect harmony.

It is a deplorable fact that commercially available tubes vary considerably in their characteristics, and proper facilities for ascertaining these necessary curves are not available to the average builder, so we shall attempt to show how the tubes may be intelligently inserted in their proper order in the circuit. The apparatus required is always available, being only the set itself. It will be assumed it is the standard model with three stages of intermediate frequency amplification controlled by one potentiometer.

The first test will be for oscillation. Since we have a part of the circuit especially designed for this test, we shall use the oscillator socket. Connect the "A" battery and see if a tube inserted in it will light. If so, connect the negative of the "B" battery to the proper terminal

lighted, a ringing sound should be heard in the phones when the tube is lightly tapped with the finger.

Oscillation Test

Now test for oscillation. Two tests are available. One is to touch the grid connection of the tube. If a loud click is heard, the tube is oscillating. The other is to attach the antenna direct on the grid of the tube, leaving the ground disconnected. On rotating the oscillator condenser, beat notes or whistles should be heard, as the connection is an oscillating receiver. If no oscillation occurs, other tubes should be tried, and if still no response is secured, the trouble is in the circuit and must be fixed before the set will operate. A very important point to be noted is that the tube must oscillate over the complete revolution of the oscillator condenser.

Every tube available should now be inserted in this socket, one at a time and all should oscillate at all points of the condenser. If some do not, they should be rejected, or used as shown later. It is suggested that all tubes now be marked with relation to their oscillatory powers.

Now remove the tube from the oscillator socket and insert it in the following socket. Tapping the tube should produce a ringing sound in the phones, as before. Make this test in the next two sockets, and if response is had in all three sockets of the intermediate stages, it is easy proof that the plate circuits in each are complete. Note: There should be only one tube in the set at any one time.

We shall now start to work from the other end. Take the phones out of the "B" battery circuit and connect all batteries to the set properly.

The Detector

Insert the telephones in the plate circuit of the second detector, usually by plugging them in the detector jack. If no jack is available, put them across the primary of the first audio transformer. It is inadvisable to use the audio frequency amplification at this time, as any trouble with it would complicate matters. Insert a tube in the second detector socket, after seeing no other tubes are in the set. On tapping as before, a slight ringing sound should be heard. Take one of the tubes which oscillated and insert it in the socket preceding the second detector, i.e., the last stage of intermediate frequency amplification. Slowly turn the potentiometer meanwhile listening with the phones, and tap the grid terminal of this last stage of intermediate amplification. A position of the potentiometer should be found which will give clicks of greatly increased volume when the grid connection is tapped. Careful note should be made of the setting of the potentiometer where this condition appears. This is very important, as it notes the point at which the tube goes into oscillation.

Now remove the tube preceding the detector, and insert another, and repeat the test. It is quite possible that it will begin to oscillate at a slightly different setting for the potentiometer. Of the tubes available, three should be chosen which go into oscillation at precisely the same point on the potentiometer, as these three tubes will have to be con-

trolled in a unit. If they go into oscillation at different points, it is evident that one will be at the point of oscillation before the other two, and if attempts are made to bring the other two up to the sensitive point, which is just below oscillation, the process will force the first tube into oscillation, and spoil reception. Therefore, all care possible should be taken to see that three tubes are obtained that will work together. These three tubes control the amplification available in the set, and if one tube should lag behind in reaching this sensitive spot just below oscillation, the amplification obtained from this stage would be negligible.

Insert the three matched tubes into the intermediate frequency amplifier sockets and check over whether they are working together by the following test (the second detector is being used, of course): Place the potentiometer in a non-oscillating position, and touch each grid in turn to see if any one is oscillating. If none oscillate, carefully advance the potentiometer a little at a time, and continue to tap each grid in succession. If the constants of the circuit of any tube are different from the others, it will either go into oscillation before the others, or behind them. The tubes which oscillate at any given moment are told by the loud click in the phones when tapping the grid. Now, by careful adjustment of the potentiometer at the point where oscillation first occurs, try to get one tube oscillating when the others are not, and also try to get two oscillating when the other is not. If no such condition can be obtained, the tubes are perfectly matched. If, however, one tube leads the other two into oscillation, or lags behind, try all tubes available in this socket, until a tube is found which will go into oscillation at exactly the same point as the other two. The intermediate frequency is now in its best position, and we can turn our attention to the other positions.

The oscillator socket is next filled with any tube which passed the initial test for oscillation. The two detectors sometimes may be poorer tubes and the requirements for the audio frequency are too familiar to discuss. The set should now work upon the insertion of the first detector.

From the above it will easily be seen that out of eight tubes, it will be easy to pick three which work together, and in case one burns out, it will be a simple matter to run through the test again, and the set will be in good working order. The advice on trouble shooting is of course quite incomplete, being outside the scope of this article.

Besides the small amount of apparatus required, the system will be found to have a distinct advantage over the method of placing tubes in the set by the relation of their mutual conductance, as frequently the circuit constants are different for each stage of intermediate frequency amplification due to the coupling of the connections, variation in coils, etc., for which no provision is made when three identical tubes are shown to work together. In the method described full allowance is made for this condition.

It might be mentioned that the above system has been used for some time by the writer, and was in every case successful.

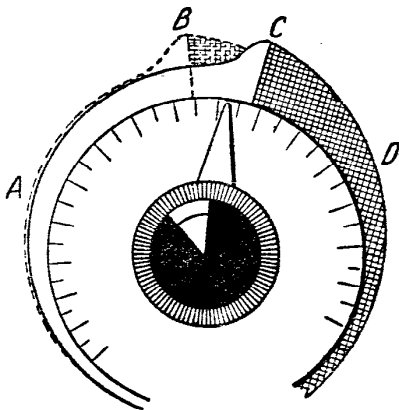

All the intermediate R. F. tubes should break into oscillation at the same point on the potentiometer scale, in this case at C. Should one of the tubes commence oscillating at point B, the sensitivity of the set is diminished. A represents the regeneration area and D the oscillation area.

on the set, but connect the positive terminal to the set through the headphones; that is, connect one phone cord tip to the positive post of the "B" battery and the other to the positive "B" battery binding post on the set. This is usually the one for the intermediate frequency amplifier, and is often marked "plus 90" or "RFB" or "Amp," and never "Det." Now take a fixed condenser of any value from .0005 mfd. to .005 mfd. and connect it across the phones. The set should only have one tube in it, and that one in the oscillator socket. When the tube is

Adjusting Your Superheterodyne

BY L. H. LA MONTAGNE

How to find and remedy possible trouble in the homemade instrument.

AFTER you have carefully wired up your Superhet, as per specifications, you may find that it will not "perk" at first. Such troubles can usually be remedied if you know what to look for.

First be sure that your sockets and intermediate frequency transformers are all right. Test out each instrument for shorts, open circuits, or grounds with a pair of phones and battery as in Fig. 1 or 2. The transformers should give a loud and distinct click when the circuit is made and broken through both the primary and secondary circuits. If shielded, test for grounds to the shield.

See that the condenser terminals make good contact. A rubbing contact, if dirty, may not be good. In soldering,

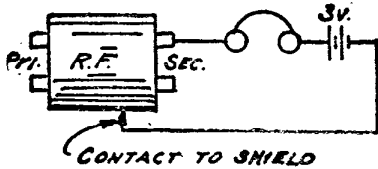

Fig. 1. Testing Secondary of I. F. Transformers. Primary tested in same manner.

be sure that the wire isn't held mechanically but makes an excellent contact as well. Stray noises, very difficult to locate, frequently come from this source,

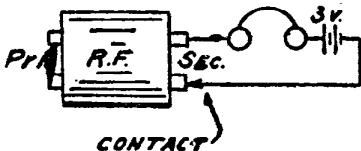

Fig. 2. Testing Secondary for Grounds. Test Primary in same manner.

especially if in the detector or oscillator circuits. Polish up all socket contacts with an ink eraser. Rub the tube terminals on a clean piece of paper or Bristol board. The lead oxide film isn't very deep and is easily removed. The thoroughness with which the various instruments are tested may mean the difference between success and failure.

Now let us suppose that you have assembled the set, and are ready for a try out. The writer has found that a meter in the positive B battery lead to all the tubes is one of the most helpful things for testing any set. The meter need not be calibrated, but may be a high voltage voltmeter minus the series resistance, as only comparative readings need be made.

The first thing to test is whether the A battery circuit is right. Place one tube in a socket, and see if it lights. If so, try this tube in each of the other sockets.

Next connect the B battery, without the meter for the moment, and short the filament leads momentarily by inserting a screw-driver between the socket contacts. If a large or unusual spark is produced, trace out the trouble. Make contact for an instant only or the bat-

teries will be run down quickly. If the proper size voltmeter is available, it would be better to use it. If these circuits test all right, place tubes in the sockets, leaving out the audio-frequency ones for the time being.

Now plug the 'fones in the detector circuit, and connect the meter in the plus B battery lead to the set. Take readings for each tube, and if there is one that seems to give unusual values, discard that one for the time being. The tubes should all be tested in the same sockets, leaving out the audio-frequency give varying space currents.

Test the potentiometer, if one is used by turning the arm until a click or hiss is heard in the 'fones, and noting the action of the meter as the tubes go in and out of oscillation for future reference. If no click or meter kick is observed, check the R.F. wiring, and if ok check the contacts on the potentiometer. There should be a circuit between its three posts regardless where the arm is placed. This is tested out by the means of battery and 'fones, Fig. 3. A grating noise as the potentiometer arm is turned indicates poor contacts on the wire, which should be cleaned by sanding lightly. If the R.F. tubes are oscillating, a distinct click will be heard in the 'fones if the grid of any tube is touched with the finger, and the meter will give an upward kick when the oscillations are stopped.

The next circuit to test is that of the oscillator. If the grid of the oscillator is touched a distinct click should be heard, and the meter should act in the same way as with the R.F. tubes, when oscillating. If the condenser is varied, a number of whistles should also be heard as it is turned through its various values.

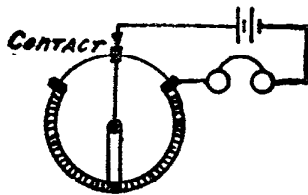

Fig. 3. Testing Potentiometer.

The commonest faults of the oscillator are: too few turns on the plate feedback (follow directions carefully); reversed plate leads; shorted or open coils, or poor contacts; or poor by-pass condensers. With an open plate coil, no space current will be shown on the meter. Lack of oscillations is shown by little or no change in the meter when the grid of the tube is touched. The filament adjustment, while not critical, must be above a certain value for oscillations to take place. I have found that nine-tenths of the troubles in a Superhet occur in the wiring of the oscillator circuit.

Now if the oscillator and R.F. tubes are working properly, tune in signals, and try out the tubes in various positions. Some tubes are good R.F. amplifiers, some good A. F. amplifiers, some

good detectors, and some distinctly no good.

Don't overlook your grid leak or condenser or any by-pass condenser. They may be way off capacity, shorted or otherwise defective.

Cut out the by-pass condensers and then connect them one by one until the trouble is found. The only test for these condensers is a comparative one made by listening to the strength of signals. Any decrease in signals will show a defective condenser, wrong capacity or incorrect position. Your meter will generally show up a defective leak, especially if its value is low, for then a positive potential is put on the grid of the detector tubes, and an abnormal plate (space) current results. A little testing will show just what to expect. A reversed C battery will also cause a tube to show an excessive plate current.

The actual tuning in is greatly simplified by the use of a meter. By noting the action of the meters as the loop (or secondary) and oscillator condensers are varied, the resonance point may be determined. The meter gives a distinct dip as a resonance is passed through,

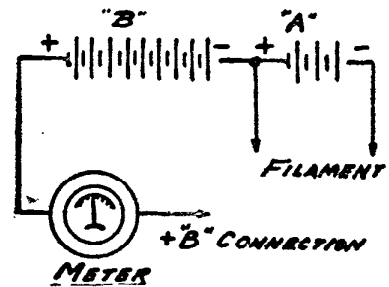

Fig. 4. Method of connecting meter.

which may be easily recognized after a little practice. The relative dip of the meter will also indicate, more or less, the strength of oscillations at that particular setting. A small change generally shows weak oscillations. With a little observation, and general knowledge of the tubes under varying conditions, it should not be difficult to correct and adjust the faults that usually occur.

As a summary the following is given:

No plate current—

- (1) Defective tubes.
- (2) Open plate circuit—
 - (a) Poor tube contact.
 - (b) Opened transformer.
 - (c) Defective wiring.

Abnormal plate current—

- (1) Positive potential on grid—
 - (a) C battery polarity reversed.
 - (b) Detector grid leak too low.

Low plate current—

- (1) Poor contacts.
- (2) C battery too high—follow instructions. See note.
- (3) B battery weak or filament low.

Note.—With correct C battery connections the plate current is very low, as compared to when it is not used. Test this out for yourself.

A buzzing sound—loud and persistent—shows an open grid circuit.

The Peanut Superheterodyne

(Continued from page 66)

Either decrease the number of loop turns or use smaller variable condenser. Use a center-tapped loop.

The writer had the pleasure of hearing the set work as soon as the wiring was completed. No trouble has been experienced for six months. It tunes sharply and gives fine DX. It is excellent for portable use, because of its compactness and efficiency, as well as the fact that dry cells can be used for filament heating, and small size 22.5-volt batteries for plate. The plates draw 12-16 milliamps, for seven tubes. Everything can be placed in a case with small loud-speaker and collapsible loop. It is suggested that a small voltmeter be mounted on the front panel. Connect it across one bank of tubes. Do not allow the filament voltage to go over 4.8 volts for four tubes.

The detector and oscillator can use 30-45 volts on the plate. The R.F. tubes will work about the same on 45 or 90 volts. Use 90 volts or higher for the audio frequency amplifier. It will be found that if the tubes ("N" or WD11 or 12) are operated at normal filament voltage, the potentiometer lever can be placed on full negative without the R.F. amplifier breaking into oscillation. Stations with waves up to 450 meters can be tuned in on two points on the oscillator dial. Waves above 450 can only be tuned in on one point.

Improvements in Best's 45,000-Cycle Superheterodyne

(Continued from page 63)

ranging from 6 to 10 volts, it is necessary to provide sufficient resistance in series with the filament circuit to reduce the voltage at the filament to 5 volts. If a 10-volt bell ringing transformer is used, with A tubes, these resistances should be 8 ohms each, and, as the Cutler-Hammer resistances are easily adjustable, this can be done very quickly. The 200-ohm potentiometer should be varied until no noise is heard in the output of the tube. The above arrangement will enable the user to handle power levels considerably in excess of that permissible with the dry cell tubes, which have only 90 volts on the plate, and 4½ volts negative grid, without the addition of a storage battery.

Fig. 3 shows the re-arrangement of apparatus on the panel, as suggested by Mr. Clair Foster, and will no doubt be of interest to everyone. Mr. Foster suggests that, inasmuch as many do not like the binding post terminals brought out on the rear of the baseboard, it would be well to mount them on the panel, and he has accordingly lengthened the panel by 1 in., and the baseboard by the same amount. He has placed the Cutler-Hammer battery switch at the right hand end of the panel, where it is close to the battery binding post terminals. These jacks have been provided in a convenient manner, so that the audio-frequency amplifier, in whole or in part, may be cut out of the circuit. In the original set, the phone jacks were placed one above the other, at the extreme right hand end of the panel, but in this case they have

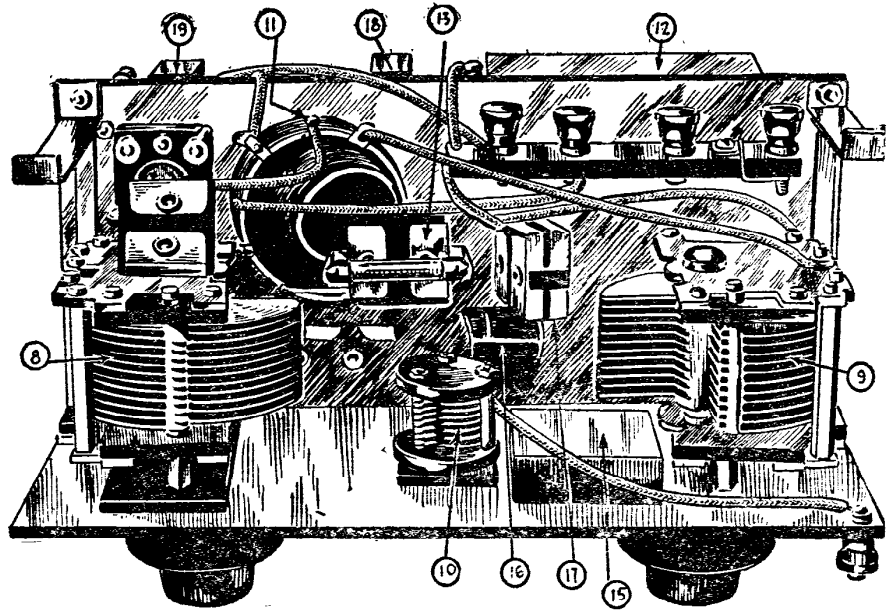

The set looking from the bottom upwards toward the sub-panel. Note the compact arrangement of all the parts. The numbers on the photograph correspond with those on the wiring diagram on page 65.

been arranged between the detector and the audio-frequency amplifier tubes, where the wiring will be very short and convenient of access.

Several readers have complained that, after constructing the antenna adapter described on pages 64 and 80, they could not use it due to lack of selectivity and noise on distant stations. This trouble is probably due to the use of too much amplification in the intermediate stages, lack of loose coupling of the rotor with the stator of the variocoupler, and lack of shielding of the cabinet in which the tuner is mounted. If the antenna tuner is to be used exclusively, sufficient amplification may be obtained by using only two intermediate stages of amplification, and, if extremely loose coupling is employed, no trouble from noise or interference from nearby stations should result. It would be best to shield the inside of the tuner cabinet with sheet brass or tinfoil, grounding the shield at the ground binding post.

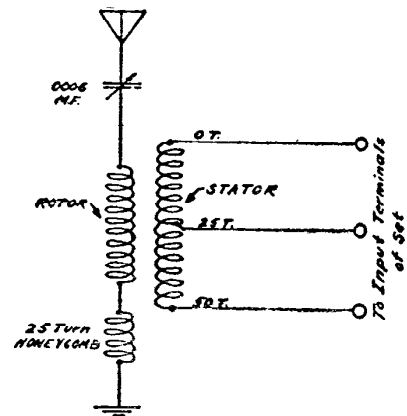

Antenna Tuner for Best's 45,000-Cycle Super-Heterodyne

Fig. 2.

More Improvements in Best's 45,000-Cycle Superheterodyne

(Continued from page 64)

ling, not only to improve selectivity, but distortion will surely result if too much energy from the antenna is permitted to pass into the first detector.

Many readers have written that they cannot afford to buy the complete set of parts recommended for building the set, and would like to wind their own transformers to cut down the cost. Data have been given on page 24 of this book, for winding the intermediate frequency transformers, and the following specifications are for a home-made tuned circuit transformer, to be used in place of the Remler No. 610 transformer, when desired: A spool of good seasoned hardwood should be turned on a lathe, so that it has flanges of ¼-in. width, a

diameter of 2½ in., a hub of 1 in. and a slot ½ in. in diameter. On this spool wind 250 turns of No. 30 D.C.C. wire, in a hap-hazard manner. Place over this winding, which is the primary, a piece of insulating paper. Over this paper wind 1800 turns of No. 36 single cotton or single silk wire, for the secondary coil. This transformer differs somewhat from the Remler No. 610 tuned transformer, and requires a condenser of .005 M. F. bridged across the primary winding, instead of the .00025 M. F. condenser bridged across the secondary winding, as is done in the case of the Remler transformer. It is very important to be sure that a fixed mica condenser of .005 M. F. is shunted across the primary circuit, and that no fixed condenser is bridged across the secondary winding, as the transformer will not function properly unless this is done. The four leads of the transformer may be connected to convenient terminals on the edge of the wooden spool.

Data on the New Pressly Superheterodyne

(Continued from page 77)

7. Wire plate and grid leads of the second, third and fourth tubes and the grid lead of the fifth tube to the four Sangamo transformers.

8. Mount the .0005 plain condenser at the left-hand side of the panel; split condenser in middle of the panel; .0005 vernier condenser right side of panel; oscillator coil directly beneath balancing condenser (tap No. 4 toward the bottom of the panel); Thordarson audio transformer 2:1 ratio right-hand lower (second step), Thordarson 6:1 ratio right-bottom center (on both of these transformers the secondary binding posts should be up, primary binding posts down); jack switch lower-left corner frame down; Benjamin battery switch just to the right of this; single circuit filament control jack bottom right; double circuit jack between the audio-frequency transformers.

9. Wire all possible leads of instruments connected to the front panel before the socket shelf is attached.

10. Attach socket shelf and complete wiring as per diagram.

11. The jack switch connections are to be made as follows: Connect middle leaf of jack switch to the rotors of the balancing condenser and the loop condenser, and then to the positive filament bus. Connect the upper leaf to the third from the left binding post on the rear of the socket shelf, and the bottom leaf (nearest frame of the switch), to the second from the left binding post.

After these operations have been completed check all wiring in order to see that proper connections have been made, and also make sure that no B and A battery wire touch each other.

In attaching the loop, if the Portena, Marion or similar loop is used, it should be tapped on the eighth complete turn counting from the inside. In connecting the loop to the set the very outside turn should be connected to the left-hand binding post on the back of the socket shelf, in connection with diagram, Fig. 2. The center tap of the loop should be connected to the second binding post to the right, L2, and the inside of the loop to the third from the left binding post, L3.

Modified Best's Superheterodyne

(Continued from page 57)

so that they will furnish a support for the panel, the mounting screws passing through holes drilled in the wooden strips

Should the constructor desire to use a loop instead of the outdoor antenna, the antenna series condenser, loading coil and coupler can be omitted, thus requiring only two variable condensers. The loop should be connected to the frequency changer as shown in Fig. 4, in which case the regenerative loop feature can be employed, using a small balancing condenser of not over 50 micromicrofarads.

In the article on page 58 the baseboard model will be described, for use especially with a loop antenna. Those who wish to employ as many of the storage battery tubes as is practicable will find the data of value, at the same time enabling the conversion of previously built sets into the new arrangement.

A Noiseless Intermediate Amplifier

(Continued from page 74)

Constructed in RADIO NEWS Laboratories, the set was found to work very well indeed. The only trouble encountered was in tuning the trap circuits, which was more tedious than actual trouble.

A glance at the photographs will at once show the proper method of arranging the parts on the baseboard. As the set is hardly one to be advised to the beginner, it is pictured here in the experimental stages. Though it may seem complicated, the man who has built a few of his own will encounter nothing in the present one to give him forebodings.

The detector and oscillator are of the standard type. The tuning coil A may be made by winding 64 turns of No. 18 S.C.C. wire on a 3-inch tube. The condensers F and E are both of the .0005 variety and are variable. The pick-up coil D may consist of 10 turns of No. 18 wound at the end of the oscillator inductance tube, which is also three inches in diameter. The plate and grid coils B and C for the oscillator may consist of 40 turns for the former and 64 for the latter, separated about half an inch from each other, on the tube.

Fifty kilocycles were selected as the best intermediate frequency at which to amplify, so of course it will be necessary to purchase three transformers designed for that frequency. And here it might not be amiss to note that, for the sake of efficiency, it is probably better to purchase these instruments than to attempt constructing them.

The condenser C1 is used to tune the transformer secondary and if it is necessary, the manufacturer of the instrument will furnish a notation with it as to the proper value for this capacity.

The resistance R1 is of 25,000 ohms value and is fixed. Since it is not in the least critical, any resistance which will fall within 20 per cent. of its rated value will suffice. The trap circuit consists of a 400-turn honeycomb coil shunted with a .001 variable condenser.

The resistance R2 may be of about three megohms if the 199 or 299 type tubes are used. It will be noted from the illustrations that this form of tube was used in the experiment. There was no mechanical or electrical reason for their use, however, and the 201A or 301A might serve as well.

In the hook-up no audio frequency is shown. Any type amplifier may be added at the output posts or incorporated in the set.

The Ultradyne Receiver

(Continued from page 71)

transformer, we would advise those who do not obtain good results with the Ultradyne receiver they have built to try a variable condenser in place of the .00025 M.F. fixed condenser across the primary of RF-1, shown in Fig. 2, Part I of this article.

Using an Outdoor Aerial

If it is desired to use an outdoor aerial with the Ultradyne receiver described in the first part, it might help in some cases to connect a variable condenser in series with a tapped inductance between the aerial and the receiver, as shown in Fig. 7, for with some types of aerials the tuning may not be sharp enough.

Thousands Use These Ingenious TRANSMITTER UNITS

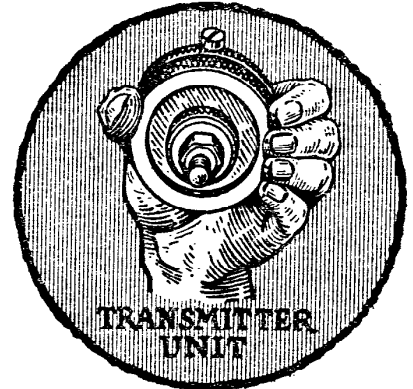

Here's a marvel of Engineering design—a practical miniature transmitter, used by thousands of radio fans and experimenters for amplification purposes. It is a most novel unit, having hundreds of uses. Every amateur should have two or three of these amplifiers in his laboratory.

A FEW USES FOR THESE UNITS

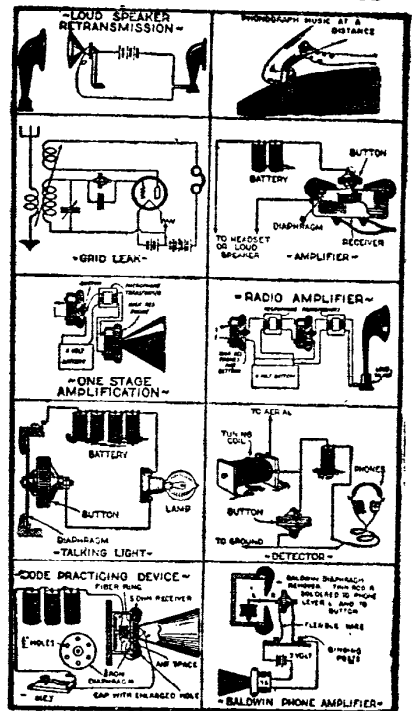

With each unit is mailed an eight-page instruction pamphlet containing suggestions for innumerable uses. Our supply is limited; avoid disappointment by ordering today. The coupon below is for your special convenience.

SPECIALY PRICED

While they last— **95c** per unit (or Two for \$1.75)

THE PRESS GUILD,
66-R West Broadway, New York, N. Y.
Enclosed find 95c/\$1.75 for which send me postpaid one/two amplifier units as advertised.
Name
Address
City, State

Patents Involving Superheterodyne Principles

THE following are a group of patents which cover many of the basic Superheterodyne principles and which cover the principles of the production of beats, as well as those of regeneration. The first four patents are the most important group of the series and upon their claims are based the suits of the Companies claiming the rights to the Superheterodyne. It is obvious that in a short resumé of the patents covering the Superheterodyne principle, it would be impossible to give them in detail, but if any of the readers of this work are interested in securing copies of the patents, they may be procured from the United States Patent Office at Washington, D. C., Patent Office coupons, coin or certified checks should be enclosed for the copies; each copy costs 10c.

It is interesting to note that the Superheterodyne as a whole has not been covered very thoroughly, and very little data concerning the construction of Superheterodyne sets can be obtained from the patents on radio receiving systems. From the technical standpoint it will be seen that the situation is fundamentally protected, and consequently, the fine points of the development hardly need to be patented.

To those experimenting with circuits we would advise that the most important thing that should be covered in any patent claim is the basic feature or features of the invention. The Superheterodyne field is without a doubt completely confined by the first four patents given here, but there are, of course, a great many others such as the patents cover-

ing many functions of grid leaks and condensers, but these latter are really secondary protections.

The reader may get a new idea from the circuits or descriptions of the patents which follow, and it is for that reason that these resúmes are published. Furthermore, no work on Superheterodyne would be complete without informing its readers what specific features are covered by the patents granted. In many cases only one of seven or eight of the patent drawings, or possibly of even more, are given in what following. The full descriptions and all of the drawings can be secured by writing to the Department of Commerce, Government Printing Office, Washington, D. C., addressing the letter to the Commissioner of Patents.

METHOD OF SIGNALING

No. 1,050,728

Issued to Reginald A. Fessenden

Although this patent was taken out in the early part of 1913, it still covers the principle of the production of beats in radio receiving sets, and is one of the basic Superheterodyne patents covering the principle and phenomena of beat production.

The invention described herein relates to certain methods of signalling generally, but more particularly to signalling by electro-magnetic waves.

The primary object of the invention is to eliminate interference and increase the

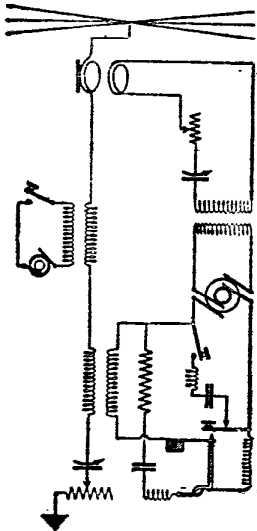

intensity of signals, by operating the indicator at the receiving station by the conjoint energy of the received electric impulses, and certain co-operating currents produced locally at the receiving station. This application furthermore contemplates the production of signals by means of harmonic beats produced between the currents of the received electric pulses and the locally produced co-operating electric pulses, the indicator being moved by the energy of the combined currents and therefore being under control, as to the frequency of motion, by the receiving operator.

For receiving it is preferred to employ an aerial similar to that used for sending,

though a different one may be used. The aerial or collector may have more inductance and less capacity relatively to the sending conductor. A circuit through which the received oscillations will flow may be arranged in operative relation to the receiving antennæ. A frequency determining element controlling a locally produced field adapted to produce an interaction with the electrostatic or electromagnetic field produced by received oscillations, is used at the receiving station.

While a variety of forms of receiving devices may be employed, the construction shown is convenient and desirable. This form consists of a light coil of wire, attached to a telephone diaphragm, and a second coil, arranged in operative relation to the coil which is arranged in operative relation to the receiving antennæ. Impulses generated and determined by the frequency determining element, for example, the current from the high frequency dynamo, or a transformer connected therewith, flow through the coil. In the circuit of the coil an inductance and a capacity both preferably variable, may be placed, and the phase of the current from the dynamo may be made to have any desired value.

Two of the fourteen claims follow:

1. In the art of electric signalling, the method which consists in moving an indicator at the receiving station by the interaction of the received impulses forming the signal, and a series of sustained electric impulses locally produced at the receiving station and maintained with a frequency near to but not the same as the frequency of the received impulses.

2. In the art of signalling, the method which consists in sending sustained oscillations and producing a signal at the receiving station by interaction of a field of force produced thereby, with a field of force produced by impulses continuously generated by a local source at the receiving station, having a frequency so differing from that of the received impulses as to produce beats.

ELECTRIC SIGNALING APPARATUS

No. 1,050,441

Issued to Reginald A. Fessenden

This is one of the four patents covering the principles involved in Superheterodyne receiving sets.

For receiving Professor Fessenden employs an aerial similar to that employed for sending, though this is not necessary, and the aerial or collector may have more inductance and less capacity than the sending conductor. A circuit through which the received oscillations may flow is arranged in operative relation to the receiving antennæ, and at the receiving station he uses a frequency determining element controlling a locally produced field adapted to interact with the received energy, as with an electrostatic or an electromagnetic field produced by the received oscillations.

As a frequency controlling device he prefers to use a high frequency alternator, or a mercury lamp producing oscillations whose frequency is maintained constant, that is to say not intermittent, by automatic means. Any other suitable source for producing unintermittent oscillations may be used, such for example

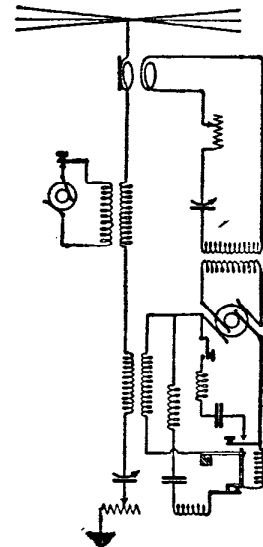

as a device operating by direct current with or without a discharge gap, as described in his U. S. Patent 706,742, dated August 12th, 1902, or a selector device as described in Patent 793,652, dated July 4th, 1905. In this case a high frequency alternator is used and the field is placed near the axis of rotation to avoid centrifugal effects. This may be driven by steam or gas turbine or an electric motor supplied from a storage battery.

The frequency is preferably maintained constant to about one-tenth of one per cent. by attaching a Weston tachometer to the shaft of the motor and placing an adjustable contact on the indicating pointer of the thermometer, so that when the speed rises or falls a suitable mechanism as rheostat will change the resistance in the field or armature and thereby restore the speed to its proper value. While this means of regulation is preferred, because the contact of the tachometer is capable of being adjusted to any desired point, and when so adjusted the speed is automatically maintained constant, yet he may of course use other means of regulation. In order to determine whether or not the frequency has the proper value, irrespective of mechanical means, a local independent resonant circuit comprising a condenser and inductance and sending or receiving device may be kept at the station for the purpose of forming a standard of frequency.

His invention relates more particularly to signalling by electromagnetic waves, and one of its primary objects is to utilize the interaction of forces produced by a continuously maintained stream of oscillations as they are received, with forces produced at the receiving station by oscillations practically continually produced by a local source.

Three of the claims made for this system follow herewith. There are 29 claims in all, covering the principle of sustaining high frequency oscillations and producing the beat effects.

1. A signalling system having in combination a sustained sending device, and at a receiving station a constantly operating frequency determining element of a frequency differing from that of the received oscillations.

METHOD OF RECEIVING HIGH FREQUENCY OSCILLATIONS

No. 1,342,885

Issued to Edwin H. Armstrong

One of the most important patents covering the Superheterodyne principle is this one of Major Armstrong. By its means the entire Superheterodyne field has been protected by the inventor of this system, who is also famous for his Regenerative patents. In addition to these two, there are two other patents which, up to the present time, have completely protected the Superheterodyne field, and they are the patents which have been granted to Professor Reginald A. Fessenden. We are showing Figures 3 and 4 of the original drawings in the patent papers.

This new method of reception consists in converting the frequency of the incoming oscillations down to some predetermined and lower value of readily amplifiable high frequency current and passing the converted current into an amplifier which is adjusted to operate well at this predetermined frequency.

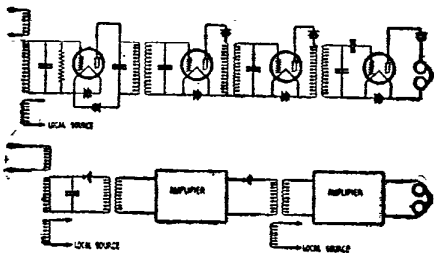

After passing through the amplifier, these oscillations are detected and indicated in the usual manner. The intermediate frequency is always above good audibility, but beyond this requirement

there is no other limitation as to what it shall be. The method of conversion preferred is the beat method known as the heterodyne principle, except that in the present system the beat frequency is always adjusted to a point above good audibility.

The process of converting the incoming high frequency oscillations down to the audible range may be carried out in several stages and each stage may be amplified by means of a multi-tube amplifier. The great advantage of this method is that the effect of the output side of the amplifier upon the input side is eliminated as the frequencies are entirely different. As a consequence of this the elimination on amplification which has always been imposed by the tendency of the amplifier to oscillate is removed, and exceedingly great amplifications become possible.

The first of 9 claims follows:

The method of amplifying and receiving high frequency electrical oscillatory energy which comprises, combining the incoming energy with locally generated high frequency continuous oscillations of a frequency differing from said incoming energy by a third readily-amplifiable high frequency, converting the combined energy by suitable means to produce said readily-amplifiable high frequency oscillations, amplifying the said third high frequency oscillations, and detecting and indicating the resulting amplified oscillations.

2. A signalling system having in combination at a receiving station, a receiver and a constantly operating frequency determining element having a frequency differing from that of the received impulses to such an extent as to cause beats to be formed at the station on the receipt of transmitted impulses.

3. In an electric wave signalling system the combination at a receiving station of a receiver, a constantly operating frequency determining element having a frequency differing from that of the received impulses to such an extent as to cause beats to be formed on the receipt at the station of transmitted impulses, means for adjusting the frequency of the determining element, so as to have any desired value and means for automatically maintaining it at the desired frequency.

WIRELESS RECEIVING SYSTEM

No. 1,113,149

Issued to E. H. Armstrong

This is another of the four most important Superheterodyne patents, and is one of those generally involved in litigation. It relates particularly to feed back circuits, and consequently covers the single tube regenerative set.

The present invention relates to improvements in the arrangement and connections of electrical apparatus at the receiving station of a wireless system, and particularly a system of this kind in which a so-called "audion" is used as the Hertzian wave detector; the object being to amplify the effect of the received waves upon the current in the telephone or other receiving circuit, to increase the loudness and definition of the sounds in the telephone or other receiver, whereby more reliable communication may be established, or a greater distance of transmission becomes possible. To this end the inventor has modified and improved upon the arrangement of the receiving circuits in a manner which will appear fully from the following description taken in connection with the accompanying drawing. As a preliminary, it is to be noted that the improved arrangement corresponds with

the ordinary arrangement of circuits in connection with an audion detector to the extent that it comprises two interlinked circuits: a tuned receiving circuit in which the audion grid is included, and

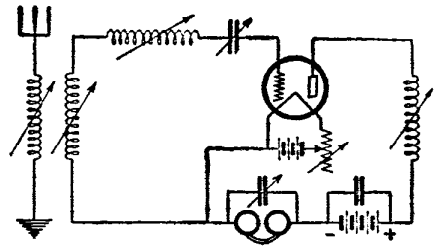

which will be hereinafter referred to as the "tuned grid circuit", and a circuit including a battery or other source of direct current and the "wing" (plate) of the audion, and which will be hereinafter referred to as the "wing circuit". As is usual, the two circuits are interlinked by connecting the hot filament of the audion to the point of junction of the tuned grid circuit and the wing circuit. The inventor departs, however, from the customary arrangement of these circuits in a manner which may, for convenience of description, be classified by analysis under three heads; firstly, the provision of means, or the arrangement of the apparatus, to impart resonance to the wing circuit so that it is capable of sustaining oscillations corresponding to the oscillations in the tuned grid circuit; secondly, the provision of means supplementing the electrostatic coupling of the audion to facilitate the transfer of energy from the wing circuit to the grid circuit, thereby reinforcing the high frequency oscillations in the grid circuit, and thirdly, the introduction into the wing circuit of an inductance through which the direct current of the wing circuit flows, and which is so related to the grid circuit that the maintaining electromotive-force across the terminals of the inductance due to reduction of the direct current, is effective in the tuned grid circuit to increase the grid charge and consequently to further reduce the current in the wing circuit and in the telephones. By a further extension of this idea, the effect of the maintaining electromotive-force upon the grid current may be augmented by the use of a transformer in a manner which will be understood from the following description.

Major Armstrong covers other forms of regeneration, but we are illustrating only one of the six different ways of effecting this regeneration. Three of the 18 claims follow herewith:

1. An audion wireless receiving system having a resonant wing circuit interlinked with a resonant grid circuit upon which the received oscillations are impressed, the resonant grid circuit having a capacity so related to the grid as to receive and retain the charge which accumulates thereon.

2. An audion wireless receiving system having a resonant wing circuit interlinked with a resonant grid circuit upon which the received oscillations are impressed, the resonant grid circuit having a capacity so related to the grid as to receive and retain the charge which accumulates thereon, and an inductance through which the current in the wing circuit flows, the grid circuit including connections for making effective upon that circuit the potential variations resulting from a change of current in the wing circuit.

3. An audion wireless receiving system having a resonant wing circuit interlinked with a resonant grid circuit upon which the received oscillations are impressed, the resonant grid circuit having

a capacity so related to the grid as to receive and retain the charge which accumulates thereon, an inductance in that portion of the connections which is common to the two circuits, a transformer having its primary in the wing circuit and its secondary in the grid circuit, and condensers affording paths of low impedance about the inductance and transformer for the high frequency oscillations in both circuits.

ELECTRIC WAVE RECEIVER

No. 1,502,063

Issued to Walter Schottky

In wireless telegraphy it is known that by super-imposing a high frequency current at the receiving station over the oscillations to be received, a variation of the wave amplitude can be generated in the apparatus whose frequency corresponds to an audible signal. A beat note is produced and can be rectified. The efficiency of the rectifier is greatly improved in this case.

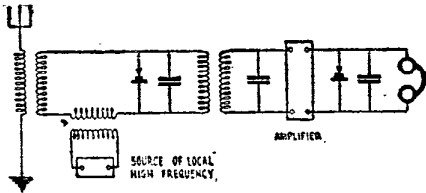

The present invention furnishes means for practically carrying out the beat reception with inaudible group frequencies. This is effected principally by the transformation of the wave current of the rectifier into an alternating current which is then rectified once more for the purpose of forming the signal. If the system would comprise merely the two detectors with a transformation of the current, which might be an inductive one, between them, the second detector (rectifier) would obtain current amplitudes which are not greater than those of the antennae current and which work in a correspondingly unfavorable manner. According to the present invention, therefore, the current is amplified between the rectifiers.

It is further possible to prevent within wide limits all troubles inherent to high and low frequency currents by tuning to the group frequency. The selective preference for a predetermined frequency may also be carried out by means of a suitable amplifier tube, those parts of said tube which are capable of resonance, being to this end tuned to the corresponding group frequency.

One of the two claims allowed for this system follows:

A receiving system for high frequency electric waves comprising in combination a local source for superimposing on the received frequency a local frequency different from that received and adapted to produce a beat frequency current above the limit of audibility, a rectifier adapted to rectify said beat frequency current, means tuned to said beat frequency for transforming said rectified current into alternating current, an amplifier tube for amplifying said current, and means for rectifying said amplified current to produce an audible signal.

WAVE RECEIVING SYSTEM

No. 1,563,644

Issued to Harold W. Nichols

In this particular patent a double detecting circuit is employed and means for varying the frequency of a local source of oscillations is also embodied in the

invention. The objects are made clear in the following extract:

An object of this invention is to eliminate the effect of interfering signal waves in a radio receiving system.

A feature employed in attaining this end is the utilization of both the sum and the difference frequency components

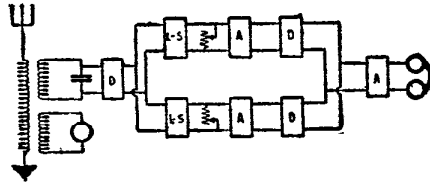

in a receiving system employing the intermediate frequency method.

In receiving by the intermediate or double detection method, incoming signal waves are combined with locally generated oscillations of a different frequency, and the combination is detected to produce a beat note equal to the difference of these two frequencies. This difference frequency is then selected, amplified, and again detected.

When there is present an interfering signal whose frequency differs from that of the locally generated oscillations by an amount equal to, or approximately equal to, the difference between the desired incoming signal and the locally generated oscillations, it is very difficult to separate these and to eliminate the effect of the interfering signal. One method of eliminating this effect is to shift the frequency of the locally generated oscillations; but if there are present several interfering signals of different frequency, this method may not be entirely effective.

The present arrangement alleviates this difficulty by utilizing both the sum and difference components of the incoming signal wave and a locally generated oscillation, i. e., the sum and difference components resulting from intermediate frequency detection are selected, separately detected, and combined in a receiver.

One of the claims allowed reads: The method of receiving signals which comprises combining incoming signal waves with locally generated oscillations of a different frequency, selecting the resultant sum and difference frequency components, separately detecting said components and combining and indicating the detected waves.

APPARATUS FOR DETECTING MINUTE VALUES OF ENERGY

No. 1,347,240

Issued to E. C. Hanson & W. L. Carlson

Although this invention relates to apparatus for detecting minute values of energy, it also includes a system applicable to radio, which should be given in this work. The illustration here given

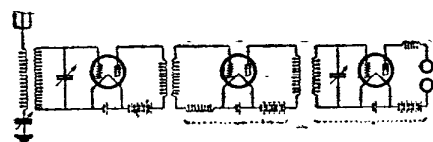

is Figure 3, and constitutes one of the four drawings covered in the patent papers.

The object of the invention is to provide suitable apparatus for detecting slight variations in the frequency of an oscillating current, said variations produced by the action of an external source of energy on the constant of the circuit producing said oscillations, or by the os-

cillating currents induced in said circuit, influencing the local oscillation.

The fundamental principle upon which this invention is based is the "heterodyning" of two or more oscillating electric currents to produce a beat, the frequency of which will be determined by the natural constants of the circuits and the external influence of an interference acting upon one of the circuits.

The inventors claim:

In an apparatus for detecting minute changes in frequency the combination of an electrically oscillating circuit, a plurality of circuits associated therewith each adapted to oscillate at different frequencies and means for observing the interaction of currents in said first named circuit and said plurality of circuits.

RECEIVING SYSTEM

No. 1,550,571

Issued to Henry Joseph Round

This is an improved method of receiving wireless signals by which the incoming signals can be affected as desired and may, when it is so required, be rendered ineffective. Whenever two high frequency currents of different frequency act simultaneously in one circuit, a beat note is produced. Sometimes this is beyond audibility. It has been discovered that the phase of the beat tone can be altered by altering the phase of either

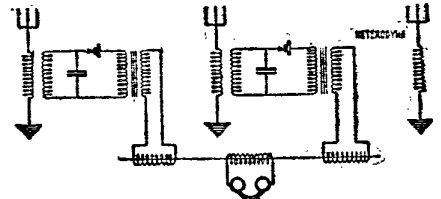

of the two original high frequency currents, the beat note shifting in direct proportion to the change in phase of one of the currents.

According to this invention incoming signals are heterodyned so as to produce a beat current and on this beat current is superimposed another current of a frequency equal to that of the beat current, the phase of the heterodyne or of the signals being adjusted so as to render the phase of the beat current such that the beat current can be added algebraically to the other current in any desired manner.

Thus if it is desired to eliminate the effect of certain signals, these signals are heterodyned so that on each of two receiving aerials, which are spaced a fraction of the wave length of the signals apart, there may be the same phase difference between the signals and the heterodyne, and therefore the beat currents in the two aerials can be made to balance one another with the result that the signals are ineffective.

Two of the thirteen claims follow:

1. A method of receiving wireless signals which consists in combining a slightly different heterodyne frequency with the signals so as to produce a beat current, superimposing on the beat current another current of the same frequency, and adjusting the phase of the heterodyne or of the signals to adjust the phase of the beat current to a desired phase relative to the other current.

2. A step in the method of eliminating certain wireless signals which consists in receiving the signals on aerials spaced apart a fraction of the signal wave length heterodyning the signals so that at any moment there may be substantially the same phase difference between the heterodyne and the signals on each of said aerials.

SELECTIVE RECEIVING SYSTEM

No. 1,420,055

Issued to Harold W. Nichols

When a receiving station is tuned to a weak transmitting station and is interfered with by a high power transmitting station, the weak station comes in so poorly that it is almost impossible to tune it in, and it is almost impossible

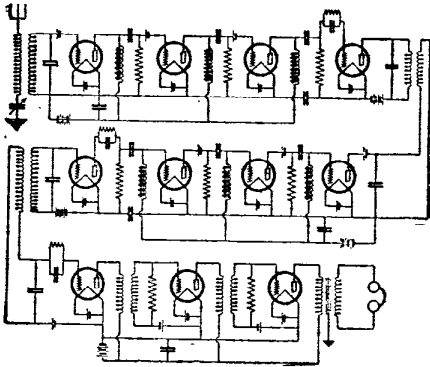

to hear that station. If the frequencies of both transmitting stations are close together, it is very difficult to separate them. By tuning to the first even harmonic, separating the stations becomes quite a simple matter, and this invention covers that method of tuning.

In this system advantage is taken of the fact that because of the curved characteristic of most detectors including the vacuum tube type, if a speech or other signal modulator carrier current is impressed on its input circuit there will be present in the output circuit the signal modulated first even harmonic of the carrier frequency and by tuning the output circuit of the detector and the coupled input circuit of the next detector to this first even harmonic considerable selectivity will be obtained.

According to the present invention the carrier wave received is impressed upon the tuned input circuit of a detector device from the output circuit of which the first even harmonic of the carrier frequency is selected and applied to the input circuit of a second detector device from the output circuit of which, in turn, the second even harmonic frequency of the carrier wave is selected. This process may be continued for any desired number of stages and the detected audio frequency signal current of the last stage is supplied to a telephone receiver or other indicator. The various stages may, if desired, be connected by amplifying devices.

In another aspect, the detectors may be considered as relay devices which serve to initiate in their output circuits oscillations which are a harmonic frequency of that supplied to their input circuits.

In an arrangement of this kind the circuits may tend to "sing" or oscillate because of the harmonically tuned input and output circuits. This may be overcome by using short twisted leads, making the tuned circuits of small inductance and large capacity and using suitable choke coils in the plate circuits of the vacuum tube devices.

One of the claims allowed is as follows:

A method of selecting modulating current impressed upon a carrier of given frequency from an interfering signal current which modulates a carrier of different frequency, which comprises impressing both incoming waves upon a circuit selective of the desired frequency, controlling by means of the waves in said circuit an independent source of energy

to initiate oscillations which are a harmonic of said selected frequency, selecting said harmonic frequency waves and controlling by means of the waves of harmonic frequency an independent source of energy to initiate oscillations which are a harmonic of the above-mentioned harmonic frequency.

RECEIVING SYSTEM

No. 1,521,380

Issued to David G. McCaa

This invention relates to a method for eliminating or reducing the effect of electrical disturbances and particularly oscillations of radio frequency.

In accordance with this invention, the effects of static, atmospheric, strays and

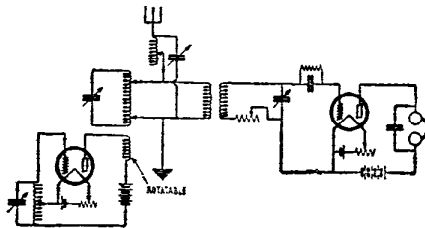

other natural or artificial disturbances including other radio signals, are reduced or eliminated in a radio or other receiving system, whereby the desired signals are readily distinguishable or become intelligible notwithstanding the simultaneous existence of strong disturbing effects.

The received energies representing both the desired signal and the disturbing effect are divided into paths including reactive devices, one of which is employed for effecting the translation of the desired signals, and with another of which is associated a local source of alternating current or oscillations in such wise as to cause the effect of said other reactance to fluctuate within wide limits and thereby causing the signal-representing energy in the first reactance to fluctuate in amplitude and at certain instants to be reinforced by energy from the local source, to the substantial exclusion or great reduction of the effects of the simultaneously existing disturbing energy.

RECEIVING SYSTEM

No. 1,522,136

Issued to David G. McCaa

This invention relates to a method of and apparatus for eliminating or reducing the effects of electrical disturbances in the reception of signals, and particularly oscillations of radio frequency.

In accordance with the invention, the received energies representing both the

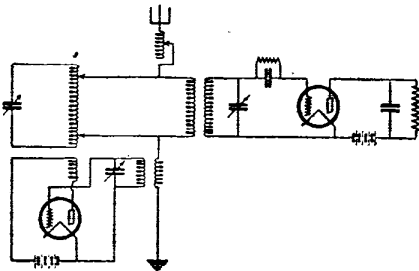

desired signal and the disturbing effect are divided between reactive paths, one of which is employed for effecting the translation of the desired signals, and with another of which is associated means for impressing thereon a part of the energy of the desired signals previously amplified, to cause a change of reactance, and thereby withholding from

the signal-translating path the effects of the undesired oscillations to greater degree than the effects of the signal-representing or desired oscillations.

The 5th claim is as follows:

Radio receiving apparatus for distinguishing between oscillations of radio frequency representing a desired signal and oscillations representing a disturbing effect, comprising signal-translating means influenced by both sets of oscillations, a reactive control path so disposed that changes in the reactance of said path cause said sets of oscillations to influence said signal-translating means to different degrees, means for amplifying a portion of the energy of the oscillations representing the desired signal, and means for impressing energy so amplified upon said control path to vary its reactance.

DEVICE FOR RECEIVING RADIO SIGNALS

No. 1,416,774

Issued to Cesare Bardeloni

An interesting patent combining the vacuum tube with a crystal detector follows: Its purpose was primarily for eliminating stray waves or static.

The object of said improvements is to utilize the ionized gas detector, not only in its characteristic action as a current rectifier and amplifier, as well as a generator of persistent oscillations, peculiar to such detectors, but also in such a way that the ionized gas detector and the rectifying device co-operating for the reception of signals, differentiate their ac-

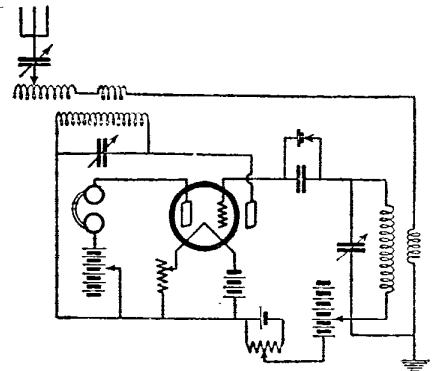

tions so as to obtain in the above-mentioned reception the elimination of disturbing oscillations, such as might be caused by other radiotelegraphic or radiotelephonic transmissions employing a slightly different wave length, or at least to lessen as much as possible the disturbances caused in the reception by atmospheric electric discharges, "stray-waves" or "statics" as they are called, or by any other disturbing causes of electro-magnetical nature to which the receiver is responsive.

Such a result is obtained, according to the present invention, by adding to the usual closed oscillating circuit of the receiving plant to which the rectifying contact and the audion grid are connected, a second closed oscillating circuit, electromagnetically or electrostatically coupled to the aerial and connected, if so required, with a second collecting plate of the audion, and working in such a manner as to eliminate (when the second named oscillating circuit is conveniently tuned) the propagation, through the first collecting plate of the audion connected to the receiving telephone apparatus, of the disturbing currents to be excluded.

The same device is also capable of reinforcing the electromagnetical signals received, for which purpose it is suffi-

cient to reverse the action of the current rectifier to adjust the potential of battery, and to tune the purating circuit or circuits exactly for the oscillation which must be received, after having coupled them to the aerial.

One of the claims allowed is as follows:

Device for receiving radiotelegraphic and radiotelephonic signals, comprising an aerial, an adjustable main oscillating circuit containing a lamp with a hot filament as cathode, a grid, and a plate, said circuit being suitably coupled to the aerial, and connected at one side to the grid and on the other side to the hot cathode of the lamp, a rectifier of variable currents connected to said circuit on the same side as the grid and hot cathode of the lamp, a receiving telephone in circuit with the plate of the lamp, and an auxiliary oscillating system which is also adjustable and suitably coupled with the aerial, said system comprising means so located relatively to the lamp that the oscillations of said system influence the electron stream of the lamp.

MEANS FOR AND METHOD OF LIMITING INTERFERENCE IN WIRELESS SIGNALING

No. 1,526,852

Issued to John Hays Hammond, Jr.

Mr. Hammond is very well known for his work in the field of electro-dynamics. His radio-controlled vessel is probably the best known fruit of his endeavors. Most of Mr. Hammond's inventions cover the field of radio dynamics, and the following may also be used in that particular field, although it is not limited to use in radio-controlled objects or mechanisms.

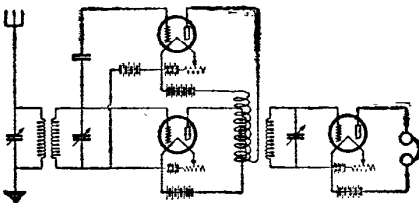

This invention relates to means for and methods of limiting the effect of interference, caused by static or other disturbances encountered in wireless telegraphy, and in the preferred embodiment thereof it depends for its operation upon characteristics of gaseous or like detectors.

In accordance with the preferred embodiment of this invention and with the preferred mode of practicing the same, he makes use of certain characteristics of gaseous detectors, and in carrying out the invention preferably provides a radio-dynamic receiving system without, however, in any way limiting the invention to use therewith, since it is clearly to be understood that the invention may be employed in radio-dynamic receiving systems of other types, and in other relations.

The claim is as follows:

A system for receiving electrical oscillations, including an oscillatory circuit, a primary detector and a secondary detector both controlled by said circuit, a pair of circuits controlled by said detectors respectively and each including a source of energy and a coil, said coils being coupled inductively to each other, an oscillatory circuit coupled inductively to both of said coils, a detector controlled by said last-mentioned circuit, and a circuit controlled by said last-mentioned detector and including a source of energy and a telephone re-

ceiver, said detectors being responsive in different degrees respectively to impulses having a given intensity.

RADIO SYSTEM

No. 1,521,777

Issued to David G. McCaa

This is another of a series of patents issued to Mr. McCaa and relates to the reception of high radio frequency energy, without interference or disturbance due to other high or radio frequency energy produced artificially or by natural electricity, as static, atmospheric, etc., in systems in which the energy is transmitted either through the natural media or over a conductor or conductors extending between transmitting and receiving stations, for purposes of effecting at

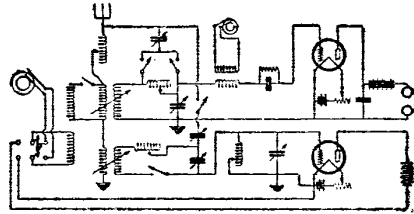

receiving stations controls, or signals which may be either telegraphic or telephonic.

In accordance with this invention, the frequency of the energy which it is desired should be excluded or reduced in effect and represented by oscillations set up by static, atmospheric or other natural electricity, is caused to differ from the frequency of the energy which it is desired shall be received, and the undesired oscillations are neutralized by an opposing and substantially equal potential caused by the received undesired oscillations, leaving the desired oscillations to effect the desired signals or controls with no or substantially no disturbance by the undesired oscillations; and preferably the undesired oscillations due to static or other natural electricity are caused to have but a single frequency. And when the undesired high or radio frequency oscillations are artificially produced, as by transmitters emitting oscillations of frequency differing from the desired oscillations, their disturbing effects are similarly eliminated or reduced.

A local source of high or radio frequency oscillations, having a frequency differing from the desired oscillations, is utilized to effect a variation of reactance whereby the desired oscillations are caused to partake of maximum amplitude in a certain part or branch of said circuit or path and thereby increase the ratio of the effect of the desired oscillations to the effect of the undesired oscillations in the ultimate translating device or signal-translating instrument. And in case the desired energy is that of undamped waves, the oscillations produced by the local source serve in addition to effect, for telegraphy, periodic variation in the combined effects of the locally produced oscillations and the desired oscillations to thereby produce an audible signal.

The 30th claim of the 65 which have been allowed for this patent reads as follows:

A receiving system comprising a path traversed by signal and static oscillations, a circuit, a coupling between said path and circuit, a coupling from a point of elevated potential in said path to said circuit for reducing the effect of the oscillations in said circuit, a signal circuit coupled to said path independently of said first named coupling, a translating instrument controlled by said signal circuit, a third circuit tuned to the signal

frequency, a coupling between said third circuit and said path independent of said first named coupling, means for amplifying the oscillations of signal frequency of said third circuit, means controlled by the amplified oscillations for controlling the transfer of oscillations from said path to said first named circuit, a local source of oscillations, and means for causing said oscillations to react with the oscillations of signal frequency to produce audible beats in said translating instrument.

METHOD AND MEANS FOR RECEIVING RADIO SIGNALS

No. 1,514,752

Issued to Peter I. Wold

This invention relates to method of and means for receiving high frequency waves and more particularly to multi-stage detection, demodulation or frequency reduction for radio signal wave reception.

In short wave radio systems, the frequency of the incoming waves is often too high to permit of efficient amplification. The use of a detecting circuit in which high frequency waves are combined with other frequency waves to reduce the effective frequency of the received waves has been suggested. In this circuit the signaling waves are combined with locally generated oscillations to give a "beat" note of frequency above the limit of audibility but low enough to be amplified, and, after amplification, are reduced by a similar operation to some audible frequency. In the suggested arrangements of this type the frequencies of the two sets of locally generated oscillations differ, hence separate local generators are required.

An object of this invention is to provide a system of this class in which a generator producing oscillations of a

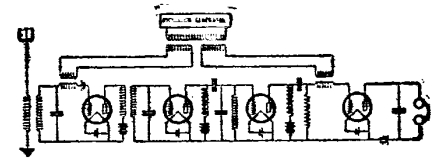

single frequency is employed to effect detection or demodulation of the signals.

Another object is to effect successive frequency reduction of incoming waves by means of oscillations from a single local source.

An additional object is to enable a local source of oscillations to be associated with different points of a receiving circuit while preventing exchange of energy between the different points of the circuit through the connection with the local source.

These objects are accomplished by employing a supply source producing alternating current of a single frequency coupled to a receiving circuit at a plurality of points, the circuit being provided with detecting, demodulating or combining means at these points and having amplifying means between each two successive detecting or combining means. In this manner the received waves are combined with alternating current from the supply source of locally generated oscillations to produce a "beat" note above the audible limit but of a frequency which may be efficiently amplified, and after being amplified the resulting "beat" frequency current is combined with the locally generated oscillations one or more times and detected. The frequency of the locally generated oscillations should be so chosen relatively to the frequency of the incoming waves that after the last step of fre-

quency reduction or detection the resulting beat note current will be of audio frequency.

The following is claimed:

A method of receiving signals which comprises combining incoming waves with locally generated oscillations of a different frequency than said waves, thereby producing "beat" frequency waves, amplifying the "beat" frequency waves, attenuating the locally generated oscillations resulting from the combining action and combining the amplified waves with the unattenuated locally generated oscillations.

METHOD OF HARMONIC OR SUBHARMONIC FREQUENCY PRODUCTION

No. 1,527,228

Issued to John C. Schelleng

The invention we hereinafter describe relates particularly to the production of oscillations and to methods of and systems for production of oscillations, the frequency of which has a definite relation to the frequency of the currents from one or more different sources. This frequency may be a multiple or a sub-multiple of a given frequency and equal

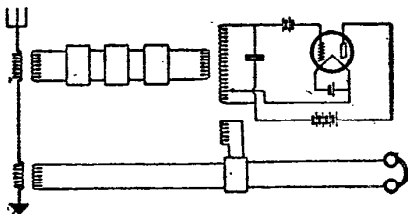

to the average of frequencies of the upper and lower sidebands of a modulated carrier wave; in other words, a wave whose frequency is the arithmetic mean of the frequencies of the two side bands.

The objects of the invention are realized in circuit arrangements utilizing an oscillator for producing a complex wave whose fundamental frequency is normally approximately that of the desired sub-harmonic frequency and having a harmonic approximately equal to the reference frequency. The current of the reference frequency is caused to coact with the current of the harmonic frequency in the oscillation circuit of the oscillator. The effect of such coaction on the oscillator is to pull it into step with the frequency of the impressed current, that is, to cause the reference and harmonic frequencies to become identical. The fundamental frequency is thus correspondingly automatically adjusted to exact sub-harmonic relationship with the reference frequency.

The above described principle has particular application in a system for deriving a carrier frequency wave from upper and lower side bands based upon the carrier frequency wave and especially in a carrier wave receiving system characterized by the transmission of a pure modulated wave, that is, a wave having no unmodulated component. The use of this type of transmission has pronounced advantages in the way of efficiency, and secrecy. Its most serious limitation has been the difficulty that attends the production at the receiver of a wave having at all times the frequency of the unmodulated carrier used at the transmitter.

The production of the unmodulated carrier may be accomplished by means of the present invention by combining the received side bands, selecting the resulting component of double carrier frequency and causing it to operate upon

a local oscillator in the manner described above to produce the first even sub-harmonic, i. e., the desired carrier frequency.

An alternative method involves the step of first producing currents whose frequencies are sub-harmonics of the respective side band frequencies and then combining these currents to produce a current of the carrier frequency.

This is one of the claims:

The method which consists in generating a reference frequency wave, generating another wave having a plurality of harmonically related frequency components, the frequency of one of which is approximately that of the reference frequency, synchronizing one of the harmonic frequencies with the reference frequency by interaction between the energies corresponding to said frequencies, and utilizing one of the other harmonic frequency components.

AUDIO FREQUENCY SELECTIVE SIGNALING SYSTEM

No. 1,525,110

Issued to Frederick K. Vreeland

When the receiving apparatus employs a simple rectifying detector, as distinguished from a beats receiver, atmospheric strays, whether aperiodic or oscillatory, are ordinarily reduced to simple aperiodic impulses, having no definite frequency of their own and hence readily distinguished from the periodic signal impulses. The audio frequency eliminator is thus relatively free from the difficulty encountered in radio frequency elimination arising from the fact that the

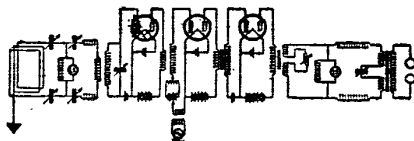

antennae or other collecting device may become the seat of shock oscillations of signal frequency which are more difficult to eliminate than aperiodic impulses, any shock oscillations of radio frequency that may be produced being converted into simple aperiodic impulses on passing through the detector.

In the case of receivers operating on the beats principle, however, radio frequency shock oscillations will produce beats with the local currents, which may be confused with the signal beats, since they have, in the arrangement ordinarily employed, the same frequency as the signal beats. Such strays, even though strongly damped, have a musical ring which is confusing to the operator and difficult to separate electrically from the signal beat note.

The present invention overcomes this difficulty by converting the energy of strays into shock oscillations of a frequency different from the signal radio frequency, which are either removed by a radio frequency eliminator as described in my concurrent application or allowed to pass through the detector, producing beats of a frequency different from the signal beat frequency which are readily distinguished from the signals by the audio frequency eliminator. The latter method possesses a distinct advantage arising from the fact that a very small difference in radio frequency produces a relatively large difference in audio frequency. For example, if the signals have a radio frequency of 100,000 cycles per second, and are caused to produce beats of an audio frequency of 1,000

cycles per second, then shock oscillations whose frequency differs only 1% from the signal frequency will produce beats differing by 100% from the signal beat frequency. They are thus far more readily separated from the signals on the audio frequency side than on the radio frequency side. As a particular case under this principle, the shock oscillations may have the same radio frequency as the local beat-producing oscillations so that the strays will produce no beats of audio frequency whatsoever, but simple aperiodic impulses.

There are a variety of effective ways of accomplishing this result. One of the simplest consist in slightly detuning the radio frequency receiving system. In a form of beats receiver quite widely employed the signal oscillations are received by a collector tuned to the signal frequency, which is coupled to a receiver circuit in which local oscillations are set up by the self-oscillation of a thermionic detector. The frequency of these local oscillations is determined by the natural period of the receiver circuit. In order that these local oscillations shall produce beats of convenient frequency with the signal oscillations this local circuit is ordinarily slightly detuned. Since the collector circuit is tuned to the signal frequency, impulsive strays will set up in it shock oscillations of signal frequency which produce confusing beats in the receiver circuit.

In carrying out the present invention, slightly detuning the collector circuit causes a small difference in the radio frequency of the shock oscillations and a relatively large difference of frequency of the shock beats as above explained.

The inventor prefers to use instead of a self-oscillating detector, a separate oscillator coupled to the receiver circuit. The receiver circuit may then be accurately tuned to the signal frequency, and hence any slight weakening of the signals which might be produced by the detuning of the collector circuit is more than offset by the accurate tuning of the receiver circuit.

The local beat producing oscillation may be combined with the signal oscillations at the collector, and the complex beat current amplified by radio frequency amplifiers, or the currents may be combined at the collector, rectified by a detector and the beat current amplified, or the signal currents alone may be amplified by radio frequency amplifiers, and the local currents combined with them to produce beats after amplification.

The 12th claim of the 34 separate claims which have been allowed on this invention reads as follows:

The method of receiving high frequency signal impulses which consists in combining these impulses with locally generated impulses of slightly different frequency, thereby producing beats of lower or audio frequency, and converting the energy of strays into shock oscillations of frequency slightly different from the signal frequency, whereby beats resulting from shock oscillations have a relatively large difference from the signal beats, separating the signal beats from the shock beats by selective admission of the signal beats and concurrent preferential diversion of the stray beats by virtue of their non-signal frequency, and receiving the energy of the signal beats, substantially as set forth.

METHOD OF AND ARRANGEMENT FOR RECEIVING ELECTRICAL OSCILLATIONS

No. 1,474,726

Issued to Dr. Alexander Meissner

The invention relates to a method of and arrangement for receiving electrical

oscillations, by the use of which important advantages are obtained, especially in heterodyne reception of undamped oscillations. In accordance with an important feature of the invention, received energy, previous to the heterodyning, is passed through a device which increases its frequency. The increase of frequency may be obtained by such a transformation or distortion respectively

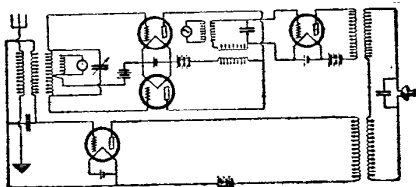

of the received energy as to give rise to a harmonic of the basic frequency of such energy. For this purpose, for instance, coils having iron cores may be used with or without saturation. Other suitable means for increasing the frequency of the received energy include vacuum tube rectifiers; thus from the plate circuit of a vacuum tube relay current of a frequency greater than that of the current supplied to the relay may be taken. The received energy may be supplied directly to the frequency increasing means at the received high frequency, or a lower frequency derived from the received energy after any suitable transformation of such energy may be supplied to the frequency increasing means. It is essential, however, that in the receiving system as a whole the received energy is changed to a higher stage of frequency previous to the heterodyning.

The invention affords a particularly large degree of freedom from troubles, but its most important advantage is considered to be that it enables the number of senders operating simultaneously on a given scope of waves to be considerably increased. In the use of long distance stations, which generally use relatively long wave lengths, the number of senders which can be operated side by side is soon reached, since to every sender a certain scope of frequency is allotted which must also be available for receiving, in order that full use may be made of the transmitter energy. The scope of frequency of each sender must include 2500 oscillations both above and below its operating frequency, and to prevent interference, other senders must remain outside of these limits. The consequence of these facts is that within a range of wave lengths from 20,000 to 50,000 oscillations, for example, only from 6 to 10 senders can be operated side by side with heterodyne reception, if signals are to be received in an unobjectionable manner. When, however, in accordance with the present invention, the frequency of the received energy is increased previous to heterodyning, the interference prevention range of ± 2500 cycles is to be taken into account with regard to the increased frequency, i. e., if, for instance, frequency of the received energy is quadrupled. Four times as many senders can be operated simultaneously side by side in the same scope of the received frequency without trouble in heterodyne reception.

The second claim, which was allowed, covers this method fairly well. It reads as follows: A method of receiving electrical oscillations which consists in producing a harmonic of the frequency of the oscillations desired to be received, heterodyning the harmonic to form a beat frequency, and detecting the beat frequency.

RECEIVING APPARATUS FOR HIGH FREQUENCY SIGNALING

No. 1,464,083

Issued to Dr. Siegmund Loewe

The present invention deals with a specially simple and convenient arrangement for producing heterodyne reception in telegraphy with or without wires. An advantage of the present method is that a special local generator circuit is

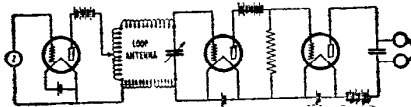

avoided and only one operation is needed to change the tuning and the frequency of the locally produced waves. There are special advantages with reference to the use of energy which are conveniently offered by the present arrangement. The system is well adapted to those types of receivers employing a local source of waves of a frequency in the neighborhood of the received waves. Claim No. 1 covers this application quite well:

A receiving system comprising a loop antenna, a receiving electric discharge tube connected across an element of said antenna, inductance in said antenna, and an electric discharge device for supplying locally produced oscillations to said antenna connected across a portion of said inductance.

RECEIVING SYSTEM FOR ELECTRIC WAVES

No. 1,457,069

Issued to Lucien Levy

This invention is essentially an improvement upon a previous patent in which the receiving circuits were tuned to the frequency of the one wave to be received and a local generator of high frequency currents was coupled to the primary circuits. The frequency differed slightly from the incoming signal so as to produce ultra acoustic beats. A secondary detector is tuned to a frequency near to the ultra acoustic frequency of these beats in such a way that beats of acoustic frequency are produced.

The present application has for its object an improvement made in the receiving system described in the original application of the applicant in the case of its application to waves emitted by ordinary stations, for the purpose of obtaining a more complete selectivity and a greater protection against atmospheric parasites.

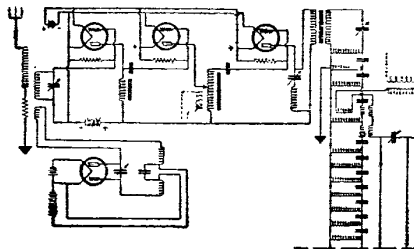

These improvements consist in:—

1. A special method of secondary selection based on the original principle described and comprising also various complementary operations intended to ensure efficient working of the system in all cases, even when the parasitic disturbances or confusion are very intense.
2. Arrangements which permit of the practical carrying out of the improved

method and ensuring very great sensitiveness of the system.

The present improved method comprises, broadly, the following operations consisting:

1. In producing in the primary detecting selector circuits, before the first detection, beats of adjustable amplitude and of adjustable ultra-acoustic frequency (of the order for example of 10,000 per second) between the currents induced in the circuits by the oscillations of the receiving antennæ and the current which is induced by a local generator of high frequency.

2. In amplifying and then detecting these beats in a detecting amplifier of high frequency.

3. In separating the numerous periods of current of ultra-acoustic frequency furnished by the detection of the beats of the continuous wave, from some periods of limited amplitude and very small in number (one or two furnished by parasites) and from the currents of low frequency coming from the succession of the parasites; this selection taking place in a secondary selector, the working of which is based generally on the known phenomena of propagation of electric waves of systems with capacities and self-inductors distributed in a relatively small number of elements.

The claim covering this method is brought out in the following:

In an antiparasitic selecting receiving system for electric waves:—means for selectively receiving on one tuned device electrical oscillating damped energy as well as sustained energy of the same primary frequency,—means for converting the frequency of this energy to lower but ultra-acoustical frequency energy,—means for separating in the ultra-acoustical frequency energies the sustained energy from the damped energy,—means for utilizing the ultra-acoustical energy for actuating the indicating means of the receiving station.

RECEIVING SYSTEM FOR RADIANT ENERGY

No. 1,469,889

Issued to Emory Leon Chaffee

In this patent we have reproduced Figures 2 and 4 of the inventor's five drawings. The figures are both described in this short resumé.

Some of the objects of this invention are to provide an improved receiving system for radiant energy adapted to receive waves of high frequency having impressed thereon a series of periodic variations of a different frequency; to provide an improved receiving system for radiant energy adapted to receive waves of high frequency having impressed thereon a plurality of series of periodic variations of frequencies differing from each other and from the high frequency; to provide in a receiving system for radiant energy improved means for increasing the selectivity of the system and for amplifying the operation of the system; and to provide other improvements.

In the operation of the system shown in Fig. 2, when electroradiant oscillations having a frequency of 1,000,000 per second, and having impressed thereon periodic amplitude variations or other variations having a frequency of 20,000 per second, are received by the open circuit 100 these oscillations thus modified act through the primary detector 106 to set up corresponding unidirectional impulses of one million per second periodically varied or modified in amplitude or otherwise at the rate of 20,000 variations per second. These unidirectional impulses act to set up oscillations having a frequency of 20,000 per second in the closed

circuit 121 and these oscillations act through the secondary amplifier 123 to set up corresponding unidirectional impulses of 20,000 per second in the circuit

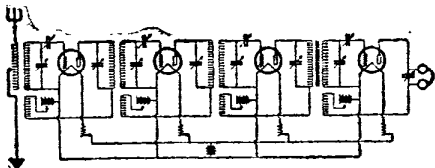

130 including the coil 131. These impulses act inductively to set up corresponding oscillations of 20,000 per second in the closed circuit 141 in which electrical beats are produced as hereinbefore described by the action of autodyne 145. These combined oscillations of 20,000 and 21,000 per second, forming the beats, act through the autodyne 145 to produce corresponding unidirectional impulses in the controlled circuit 150 which act inductively upon the closed circuit 162 to set up therein oscillations having a frequency of 1,000 per second which are detected and amplified by the amplifier 165 to cause corresponding unidirectional impulses of 1,000 per second to be set up through the circuit 170 containing the telephone receiver 171, and these impulses cause the receiver 171 to emit an audible tone having 1,000 vibrations per second.

One of the claims granted is as follows:

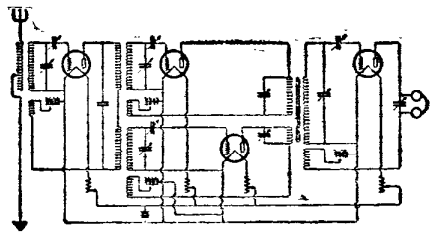

In a receiving system for radiant energy the combination with an initial receiving circuit responsive to a wave of radiant energy having a predetermined frequency and modulated at a second frequency of means controlled by said receiving means and tuned to respond to said predetermined secondary frequency, local means including an autodyne arranged to produce oscillations having a frequency different from said secondary frequency, and to co-operate with said second mentioned means to produce electrical beats, and a receiving device arranged to be controlled as a result of the action of said electrical beats.

RECEIVER FOR WIRELESS TELEGRAPHY

No. 1,472,092

Issued to Henry Joseph Round

This invention is primarily for the elimination of atmospheric disturbances. Use of the beat principle is involved wherein F in the accompanying illustration serves as a source of local continuous oscillation supply.

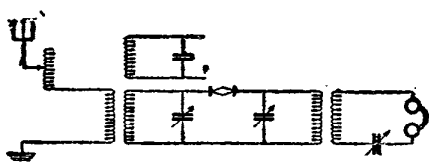

According to the present invention the inventor makes the natural frequency of the receiving aerial different from that of the received waves so that both the

forced and the free oscillations occur producing the well known phenomenon of beats and he rectifies the resultant current and carries it to a circuit tuned to the beat frequency and directly or indirectly connects a telephone to this tuned circuit. The oscillations produced by an atmospheric last for a very short time, and in order that they shall not affect the circuit tuned to the beat frequency, it is necessary for this frequency to be comparatively high so that several beats may occur before the oscillations due to the atmospheric die out. Where this necessitates the beat frequency being above the limit of audibility it is necessary to employ one of the well known devices for causing these beats to produce audible indications as for example a rectifier, or in the case of continuous waves a ticker or the generation of another frequency which will interfere with the inaudible frequency and produce beats of an audible frequency.

Where such a device is used for receiving continuous or nearly continuous waves, it is obvious that the transient free oscillations of the aerial will not produce effective beats with the continuing forced oscillations, and in such cases it is desirable to generate a continuous oscillation of a frequency which is different from that of the forced oscillations and may be equal to the natural frequency of the aerial. These locally produced oscillations will interfere with the forced oscillations and produce the required beat frequency, while they either will not interfere with the free oscillations produced by atmospherics or will produce an entirely different beat frequency which will not affect the tuned circuit.

The rectifiers employed should not reach a condition of saturation so that the oscillations due to the received waves may not be impaired by simultaneous oscillations due to atmospherics, the method of elimination depending upon the production by oscillations having slightly different frequencies of beats having widely different frequencies one of which can be detected independently of the other.

One of the claims covering this method is as follows:

In a radio receiving system the combination of high frequency circuits comprising an aerial slightly out of tune with the signal waves, a receiving circuit coupled thereto, a source of local oscillations coupled to the high frequency circuits, a low frequency circuit tuned to a frequency equalling the difference between the aerial frequency and the signal frequency, and rectifying means between said receiving circuit and said low frequency circuit.

WIRELESS RECEIVING SYSTEM

No. 1,362,612

Issued to Lloyd Espenschied

Although this patent does not cover the beat reception of radio messages, it covers the shock excitation system which has not been developed to a very great extent for the reception of radio messages.

It is well known to those acquainted with the art that atmospheric or static interference constitutes a very serious menace to the satisfactory reception of wireless messages and that the elimination of said interference is a problem of great difficulty. This difficulty inheres in the fact that the frequency to which the receiving system is tuned, and is therefore most responsive, is very closely the same as the frequency of the natural oscillations set up by the incidence of an atmospheric disturbance on the re-

ceiving antennæ. The natural oscillations are therefore of substantially the frequency to most strongly affect the receiving device, and cannot be eliminated by tuning as can persistent disturbances from a foreign station.

This invention contemplates an arrangement by which the receiving device in addition to being operatively connected to the receiving antennæ is also connected to an auxiliary circuit which stimulates the receiving antennæ as regards natural oscillations, means being provided for exciting natural oscillations in said auxiliary circuit simultaneously with the excitation of natural oscillations in the receiving antennæ by transient disturbances.

For this system the following claim is made:

In a wireless signaling system, the method for suppressing static interference which consists in permitting static impulses to be impressed on a tuned antenna and an aperiodic antenna, producing by the impulses of the said aperiodic antenna shock excited oscillations having the same periodicity and damping characteristics as the natural oscillations to which the said tuned antenna is reso-

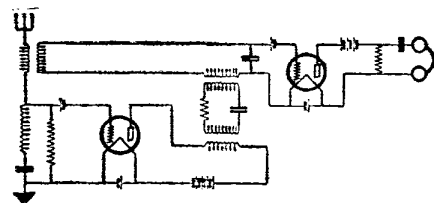

nant, and impressing the natural oscillations from said tuned antenna and the shock excited oscillations upon a receiving circuit in such manner that the two sets of oscillations will be opposed and neutralized.

PLURAL MODULATION AND DEMODULATION CIRCUITS

No. 1,447,204

Issued to Lloyd Espenschied

This invention covers a method of transmitting radio messages, and includes a system for receiving radio messages. Inasmuch as the transmitting end of the patent does not interest us particularly in this work, we are here giving the most important features of the receiving end.

As a development of the method involved in this invention the successive steps of demodulation may be increased as will be clear from the following concrete statement of the method illustrated in Fig. 5 of the patent drawings which we show here. Let it be assumed that at a given station it is desired to select all frequencies lying between 600,000 and 610,000 cycles and to exclude all frequencies lying outside of that range. If the selection were to be made by the ordinary methods of discrimination now practised in the radio art this would involve excluding such frequencies as 599,500 cycles 610,500 cycles, which would be practically impossible. It is therefore proposed to impress the various received frequencies upon a circuit tuned sharply to about 605,000 cycles, which, it will be noted, is practically the mean of the limiting frequencies of the desired band. Since the desired band is relatively narrow as compared with the range of frequencies extending from zero up to the desired frequency, this step would give practically uniform reception for the frequencies between 600,000 and 610,000 cycles and decreasing reception for other frequencies. Such a circuit might, for example, give only ten per cent. reception of current of 550 000 cycles.

The next step of the method involves beating the various frequencies with a locally supplied frequency for the purpose of stepping down the frequency of the desired band. The locally supplied frequency should be chosen as close as possible to the desired band and should be sufficiently below that band, so that

frequency between the selected frequency and the radio band, selecting frequencies from the resultant band into receiving circuits, and detecting from the resultant frequencies low frequency signals.

PLURAL DEMODULATION-CIRCUITS

No. 1,361,487

Issued to Harold S. Osborne

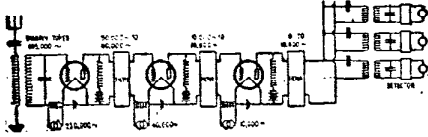

frequencies resulting from the reaction of the local frequency with the undesired frequencies will, if they fall within the limits of the band resulting from the reaction of the desired frequencies with the locally supplied frequency, be practically of negligible amplitude. For instance, assuming that a frequency of 550,000 cycles be used for beating the received frequencies, this would reduce the desired frequencies to a band between 50,000 and 60,000 cycles, which would be transmitted to the next circuit through a band filter. Although frequencies between 50,000 cycles and 60,000 cycles would also be produced by the reaction of the locally supplied 550,000 cycle currents with received currents in the range between 500,000 and 490,000 cycles, since the last mentioned band of frequencies is quite distant from the frequency to which the first circuit is tuned, the resultant frequencies between 50,000 and 60,000 cycles will be of very small amplitude as compared with frequencies within the same range resulting from the stepping down of the desired band of frequencies.

After stepping down the desired band of frequencies and filtering in the manner just described, the resultant band may be again stepped down by beating with locally supplied currents of a lower frequency which should be chosen with regard to the same considerations as stated in connection with the first step of lowering frequency. If it be assumed for purposes of illustration, that the second locally supplied frequency be 40,000 cycles, its reaction with the selected band would reduce the frequencies of said band to the range between 10,000 and 20,000 cycles. This range would then again be passed through a band filter.

The process may be continued as many times as may be necessary to pick out the high frequencies desired. In the case supposed, probably a third stepping down of the frequency would be sufficient. For instance, if the band between 10,000 and 20,000 cycles is beaten with a locally supplied frequency of 10,000 cycles, the currents will then lie in the frequency range from zero to 10,000 cycles and interfering currents would be eliminated.

One of the claims covering the receiving end of this patent is as follows:

The method of radio signalling, which consists in receiving a band of radio frequencies, obtaining from said band a controlling frequency, producing other frequencies determined by said controlling frequency, selecting one of the frequencies produced, beating the band of radio frequencies with the selected frequency, thereby producing a band of frequencies equal to the difference in

In this method, selection of desired frequencies is accomplished by having a series of oscillators and also a series of filters. Beats are produced with a frequency lower than the desired band, and from the resultant frequencies a band corresponding to the desired band lowered in the frequency spectrum is selected. This is successively stepped down in a plurality of steps to a frequency range sufficiently low for efficient selection of individual frequencies.

Other features of the method involved in this invention will be clear from the following method. Let it be assumed that at a given station it is desired to select all frequencies lying between 600,000 and 610,000 cycles and to exclude all frequencies lying outside of that range. If the selection were to be made by the ordinary methods of discrimination now practiced in the radio art this would involve excluding such frequencies as 599,500 and 610,500 cycles, which would be practically impossible. It is therefore proposed to impress the various received frequencies upon a circuit tuned sharply to about 605,000 cycles, which, it will be noted, is practically the mean of the limiting frequencies of the desired band. Since the desired band is relatively narrow as compared with the range of frequencies extending from zero up to the desired frequency, this step would give practically uniform reception for the frequencies between 600,000 and 610,000 cycles and decreasing reception for other frequencies. Such a circuit might, for example, give only ten per cent. reception of current of 550,000 cycles.

The next step of the method involves beating the various frequencies with a locally supplied frequency for the purpose of stepping down the frequency of the desired band. The locally supplied frequency should be chosen as close as possible to the desired band and should be sufficiently below said band, so that frequencies resulting from the reaction of the local frequency with the undesired frequencies will, if they fall within the limits of the band resulting from the reaction of the desired frequencies with the locally supplied frequency, be of practically negligible amplitude. For instance assuming that a frequency of 550,000 cycles be used for beating the received frequencies, this would reduce the de-

sired frequencies to a band between 50,000 and 60,000 cycles, which would be transmitted to the next circuit through a band filter. Although frequencies between 50,000 cycles and 60,000 cycles would also be produced by the reaction of the locally supplied 550,000 cycle currents with received currents in the range between 500,000 and 490,000 cycles, since the last mentioned band of frequencies is quite distant from the frequency to which the first circuit is tuned, the resultant frequencies between 50,000 and 60,000 cycles will be of very small amplitude as compared with frequencies within the same range resulting from the stepping down of the desired band of frequencies.

After stepping down the desired band of frequencies and filtering in the manner just described, the resultant band may be again stepped down by beating with locally supplied currents of a lower frequency which should be chosen with regard to the same considerations as stated in connection with the first step of lowering frequency. If it be assumed for purposes of illustration, that the second locally supplied frequency be 40,000 cycles, its reaction with the selected band would reduce the frequencies of said band to the range between 10,000 and 20,000 cycles. This range would then again be passed through a band filter.

The process may be continued as many times as may be necessary to pick out the high frequencies desired. In the case supposed, probably a third stepping down of the frequency would be sufficient. For instance, if the band between 10,000 and 20,000 cycles is beaten with a locally supplied frequency of 10,000 cycles, the currents will then lie in the frequency range from zero to 10,000 cycles and interfering currents would be eliminated.

One of Mr. Osborne's claims for his invention is:

The method of radio signalling which consists in impressing a desired band of frequencies, together with undesired frequencies, upon a circuit tuned to a frequency which is substantially a means of the limiting frequencies of the desired band, beating the received frequencies with a locally supplied frequency which is as close as possible to the desired band, but sufficiently remote therefrom, so that of the frequencies in the resultant band corresponding to the desired band stepped down to a lower position in the frequency spectrum, those frequencies which are the result of the reaction of the locally supplied frequency with undesired frequencies will be of very small amplitude as compared with that of the other frequencies in the band, which are the result of the reaction of the locally supplied frequency with the desired received band of frequencies.

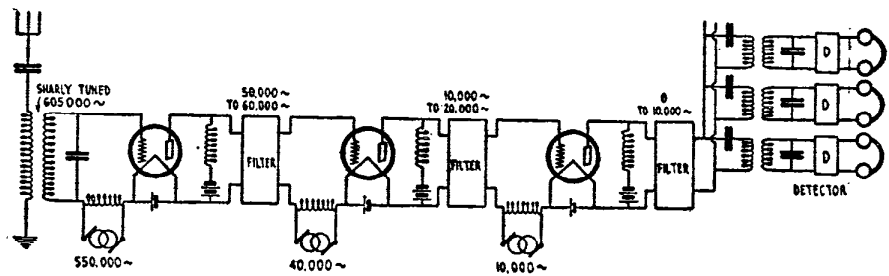

Important Note!

As this book goes to press, Federal Judge Thompson held in Federal Court of the Eastern District of Pennsylvania that Dr. Lee de Forest was the original inventor of the "Feedback" Circuit. This gives Dr. de Forest the decision over Major Armstrong and produces thereby the second most basic patent in the history of radio. In 1924 the District of Columbia Court of Appeals reversed the decision of the Commission of Patents and granted priority to Dr. de Forest over Major Armstrong. Many of the large radio companies continued to manufacture radio sets using the infringing Armstrong Circuit because the U. S. Court of Appeals in New York sustained the Armstrong patent but now Federal Judge Thompson decided that Dr. de Forest was the original inventor of the "Feedback" Circuit and the Oscillatory Audion.

TO OUR READERS

Dear Reader:

We are anxious to know if you like this book. We have taken great pains to collect a large number of articles covering this most popular circuit.

Won't you please let us hear from you after you have finished reading this book and also let us know if you would buy this book if we published another edition in about six months.

Kindly let us have your opinion on the attached form.

Very truly yours,

THE EDITORS.

**EXPERIMENTER PUBLISHING COMPANY,
53 Park Place,
New York, N. Y.**

.....
.....
.....
.....
.....
.....
.....
.....

Name.....

Address.....

City.....State.....

SPECIAL SUBSCRIPTION OFFER!

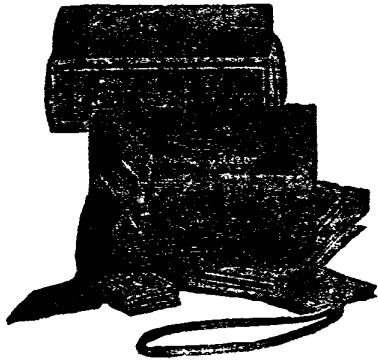

This handsome VALET Auto-Strop Razor FREE —with every five months' subscription to "Radio News" or "Science and Invention"

IN order to acquaint the readers of this book with RADIO NEWS and SCIENCE and INVENTION, we are making, for a limited time, special reduced rates and are also giving FREE one complete VALET Auto-Strop Razor shown above.

For only \$1 (Regular Newsstand price \$1.25) you can obtain either of these magazines for five months and also, one FREE Razor—

This shaving outfit consists of a highly-polished, nickel-plated, self-stropping Razor; one blade, leather strop especially prepared. The razor case is of metal, finished in maroon, crystalized effect. Lined throughout with velvet, harmonizing with the pleasing color scheme of the entire package.

The only razor in the world that sharpens its own blades.

RADIO NEWS is the largest radio magazine published. It is the outstanding authority in the radio field, carrying

more new developments, more hookups and more news than any other radio magazine.

RADIO NEWS carries in every issue more than a dozen separate departments that cover every angle of the great industry from the beginner to the professional broadcaster or ship operator.

SCIENCE and INVENTION thoroughly covers every important and interesting event of the scientific or inventive world that occurs from day to day. All of the latest developments in Electrics, Patents, Chemistry, Mechanics, Magic and Psychic Phenomena, Automotive Subjects, etc., are written up and illustrated. This fascinating magazine also makes a big hit with the radio beginner. In every issue the sound practical fundamentals of radio are carefully and completely explained and simplified.

Don't miss this big offer, the supply of premiums is limited—Clip the coupon below NOW.



PIN A \$1 BILL, MONEY ORDER OR CHECK TO THIS COUPON

EXPERIMENTER PUBLISHING CO., Inc.
53 PARK PLACE, NEW YORK, N. Y.

A.S.7

Gentlemen, enclosed is \$1 for 5 months' subscription to RADIO NEWS or SCIENCE and INVENTION. You are also to send me one complete razor as advertised FREE.

Name.....

Address.....

City, State.....

The coupon below is for your convenience, clip it today and pin a \$1 bill, money order, or check to it. Fill out the Coupon with your complete name and address NOW and check magazine desired.

EXPERIMENTER PUBLISHING CO., Inc.

53 Park Place

NEW YORK, N. Y.

Watch for the Big FALL Issue!

50c
THE COPY

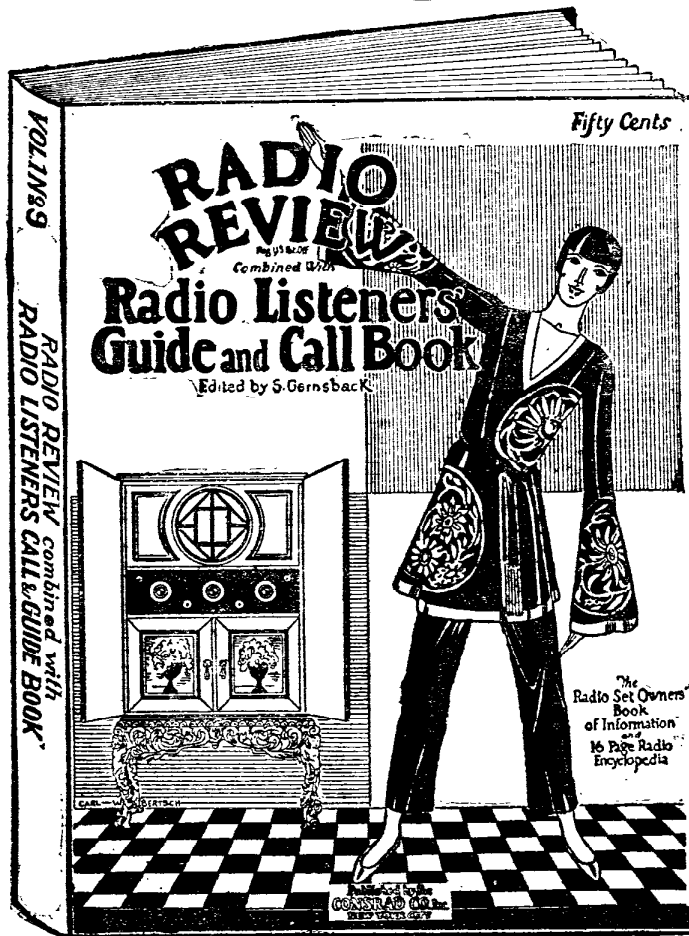

**SOLD ON
ALL
NEWS-
STANDS**

Contents

BROADCAST STATIONS OF THE U. S.

(Alphabetically by call letters)

This section contains all the Broadcast Stations of the United States listed by Call Letters, giving location, Power, Wavelength, time and hours of operation.

BROADCAST STATIONS OF THE U. S.

(By Wavelength & Frequencies)

This is a complete list of Broadcast Stations of the U. S. same as above, but listed numerically by Wavelength for added convenience.

BROADCAST STATIONS OF THE U. S.

(By States & Cities)

Another way of listing all U. S. Broadcast Stations. Especially valuable when location of a given station is known but the call letters indistinguishable by Radio.

CANADIAN RADIO BROADCAST STATIONS

(By Provinces & Cities)

This section contains the finest revised list of all Canadian broadcast stations obtainable. Listed two ways.

FOREIGN RADIO BROADCAST STATIONS

(By Countries & Cities)

A section containing the latest, most complete list of Foreign Broadcast Stations ever published.

Contents

RADIO SET OWNERS BOOK OF INFORMATION

In this portion of Radio Review are a large number of selected articles each of great value to every Radio Listener whether he be a beginner, Amateur or Professional.

RADIO EXERCISE CHARTS

A guide to Radio Exercises containing helpful charts of actual exercises and similar information.

CONSTRUCTION OF MODERN CIRCUITS

Here is one of the latest additions to the great Radio Review—gives complete details with drawings on how to build at home the latest Radio Receivers.

S. GERNSBACK'S RADIO ENCYCLOPEDIA

Radio's finest Encyclopedia—One complete installment given in every issue of Radio Review—contains a whole barrelful of actual, authentic data and information on Radio from every angle.

ILLUSTRATIONS

Throughout the broadcast station lists are hundreds of illustrations of living performers and announcers, together with photos of broadcast stations.

The Radio Listeners greatest Call Book—and Book of information COMBINED

Imagine the finest, most up-to-date list of Radio broadcast stations obtainable—listed 3 ways for convenience and giving the operating hours of each station—add a dozen fine articles on the operation and care of Radio sets—More fine constructional articles and lastly a complete installment of S. Gernsback's Radio Encyclopedia—and you have the big, new Fall RADIO REVIEW—192 pages, large size 9x12 inches. Photographs of all living Broadcast Performers and Announcers and hundreds of interesting illustrations.

THE CONSRAD COMPANY, Inc.,
53 Park Place, New York, N. Y.

Gentlemen:—I enclose 50c for one copy of the new FALL ISSUE of RADIO REVIEW.

NAME

ADDRESS

CITY, STATE

**IF YOUR DEALER CANNOT
SUPPLY YOU USE THIS
COUPON**

The Consrad Co., Inc.
53 Park Place New York, N. Y.

Books that Instruct and Entertain!

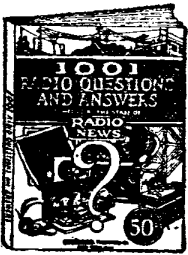

1001 Radio Questions And Answers

—by the Staff of
"RADIO NEWS"

A Book Full of Everyday Radio Problems and How to Solve Them

In presenting this most valuable assortment of questions and in answering them in the best and most understandable way, the staff of "RADIO NEWS" feels that it has created a book in which appears the cream of every radio man's problems and the best method of coping with them. There is contained invaluable information on every phase of radio. Information on hundreds of simple and complex hookups is given in clear and concise language. Information on practically every type of receiving set, manufactured receivers, vacuum tubes, miscellaneous circuits, and in short just what the radio enthusiast needs as an unerring guide and aid. This book abounds in priceless data that is worth far more than the nominal price at which it sells.

116 PAGES 300 ILLUSTRATIONS.
SIZE 9 x 12 INCHES.

PRICE
50¢



500 Radio Wrinkles

A Veritable Storehouse of Prac- tical Short Cuts and Hints on Radio Equipment

The 500 RADIO WRINKLES BOOK is a very comprehensive compilation of the best time and money saving hints that can be effected. Under fifteen separate and distinct headings, the entire field of radio apparatus and instruments has been covered in simple, understandable language. There are no ifs nor buts to complicate directions. The Beginner as well as the more advanced radio man will soon find that this book contains a veritable storehouse of practical, inexpensive hints toward improving his radio apparatus.

100 Pages. Illustrated. Size 9x12 Inches.

PRICE
50¢



Popular Magic

Surprise Your Friends
with a Mastery of
Mystery

Be the popular man in your circle of friends. You can entertain them and hold their attention with a thousand surprises and novelties.

POPULAR MAGIC is a book for you, for everybody, young or old. But especially for those who want popularity, those who want to realize how much the admiration of friends helps toward making life worth more.

POPULAR MAGIC contains thousands of simple, entertaining parlor tricks, as many puzzling magical stunts and a whole book full of mystic spirit novelties. A new set of tricks for every day of the year. Compiled from the great magazine "Science and Invention."
300 Illustrations. Size 9x12 Inches.

PRICE
50¢

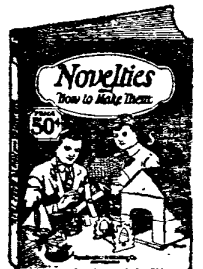

Novelties How to Make Them

Make Hundreds of Re-
markable Things
at Home

Almost every home has an old clock around—Do you know that a great many surprising, fun making and useful novelties can be made just from the old springs, the gears, etc.

NOVELTIES, the new book, compiled by the staff of SCIENCE & INVENTION shows you how to make hundreds of wonderful Novelties, mostly out of old scrap things laying around the house. 116 Pages, in this book, show pictures, diagrams and explanations of remarkable, interesting things to make in your spare time.

116 Pages. 300 Illustrations.
Size 9 x 12 Inches.

PRICE
50¢

SOLD ON ALL NEWSSTANDS

If your newsdealer cannot supply you, order direct.

Published by
EXPERIMENTAL PUBLISHING CO.
53 PARK PLACE, NEW YORK, N. Y.

"BUILD YOUR OWN" WITH "RASCO" PARTS!





Buy from the Oldest and Original Exclusive Radio Parts House in the United States

We pay ALL transportation charges in U. S. ALL GOODS SENT PREPAID IN 24 HOURS

Order direct from this page

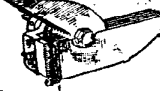
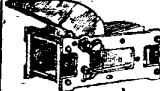



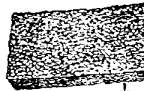

SPECIAL PRICES FOR SUMMER







Money refunded if goods do not satisfy

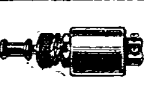

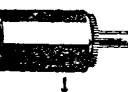
 <p>Dial Marker The big little thing you have been waiting for. Just drill a hole in the panel and mount the marker above the dial. Nickel plated and polished. F7788 Dial Marker, three for\$1.10</p>	 <p>Patent S.L.F. Condensers The famous Patent S.L.F. Condenser. The latest word in condensers. Sturdy, compact, take up less room than most others. Minimum insulation used. F4432 .00035 mf. 17. plate\$2.95 F4433 .0005 mf. 23 plate 3.95</p>	 <p>S.L.F. Condensers Lowest prices ever offered. Despite this low price, these condensers are made with precision aluminum stampings, hard rubber insulation. Money back if not satisfactory. F3513 .00023 13 pl. \$1.06 F3517 .00035 17 pl. 1.29 F3523 .0005 23 pl. 1.35</p>	 <p>"Guaranteed" Vacuum Tubes We consider the "Guaranteed" tube one of the best on the market. Any tube replaced if defective, providing filament lights, calibrated curve goes with each tube. F701A 5 v. .25 amp. \$1.25 F799 3 volt. .06 amp. 1.25</p>	 <p>Audio Transformer This is the famous Patent Audioformer. Nickel case is grounded to base. Extra high degree of amplification. Minimum distortion and reaction. Binding posts and solder lugs. Ratio 3½ to 1. F2811 Mounted type \$4.50 F2812 Unmounted . . 3.15</p>	 <p>Audio Frequency Transformer No better Transformer made. Highest class materials. Impregnated coils. Silicon steel stampings used. Save 50 per cent by assembling it yourself. F1100 Ratio 4:1. . . \$1.40 F1150 Ratio 6½:1. . . 1.40</p>	 <p>Sponge-Rubber Cushions Get rid of tube noises due to vibration. Softest sponge rubber made. Size 3½"x3", ¾" thick. F8989 Sponge-rubber cushions, each\$0.12 Six for 0.60</p>
--------------------------------------------------------------------------------------------------------------------------------------------------------------------------------------------------------------------------------------------------------------------------------------------------------------	------------------------------------------------------------------------------------------------------------------------------------------------------------------------------------------------------------------------------------------------------------------------------------------------------------------------------------------------------------------	----------------------------------------------------------------------------------------------------------------------------------------------------------------------------------------------------------------------------------------------------------------------------------------------------------------------------------------------------------------------------------------	---------------------------------------------------------------------------------------------------------------------------------------------------------------------------------------------------------------------------------------------------------------------------------------------------------------------------------------------------------------	------------------------------------------------------------------------------------------------------------------------------------------------------------------------------------------------------------------------------------------------------------------------------------------------------------------------------------------------------------------------------	----------------------------------------------------------------------------------------------------------------------------------------------------------------------------------------------------------------------------------------------------------------------------------------------------------------------------------------------------	----------------------------------------------------------------------------------------------------------------------------------------------------------------------------------------------------------------------------------------------------------------------------------------------------

 <p>Universal Socket Takes new "Ox" type tubes as well as old standard "UV" and "CO" types. Made entirely of Isolantite. No capacity effect between plate and grid. New phosphor bronze wiping contacts. Standard mounting type. F6514\$0.49</p>	 <p>Rasco Vernier Why use a vernier dial when a vernier attachment will do anything and everything a vernier dial accomplishes? Cleverest vernier made. Can be used with dial. Soft rubber ring engages dial. Nothing to come apart. F1450 Vernier.\$0.12</p>	 <p>FONEKUSHIONS Made of sponge rubber. Make wearing your receivers a pleasure. Positively excludes all noises and make reception a pleasure. Sponge rubber will last for years. Light as a feather. Sanitary. F3550 Fonekushions, set of two\$0.35</p>	 <p>Dial Button Made in blue enamel and gold, to be worn in button hole. Every radio fan wants one. ¾" diameter, best gold plate. Perfect reproduction of radio dial. F799 Dial Button,\$0.25</p>	 <p>Vacuum Tube Shell Nickel plated shell for the man who builds his own. 4 holes to attach to sub-base. Each shell comes complete with 4 phosphor bronze sockets contacts. See illus. 4747. F4747 Vacuum Tube Shell and Contacts\$0.16 Each</p>	 <p>Cord Tip Jack Takes place of binding posts. Cord tip firmly gripped by jack. Made of brass, nickel plated. Screw to attach lead wire. No soldering necessary. F1500 Cord tip jack,\$0.15</p>	 <p>Brass Nickel Electro Brackets All illustrations ¼ size. F1565 Bracket, each \$0.05 F1507 Bracket, each .05 F1509 Bracket, each .04 F1476 Bracket, each .06 F1506 Bracket, each .05 F1490 Bracket, each .04 F1475 Bracket, each .03 F1596 Bracket, each .05</p>
--------------------------------------------------------------------------------------------------------------------------------------------------------------------------------------------------------------------------------------------------------------------------------------------------------------------------------------------------------	------------------------------------------------------------------------------------------------------------------------------------------------------------------------------------------------------------------------------------------------------------------------------------------------------------------------------------------------------------------------	---------------------------------------------------------------------------------------------------------------------------------------------------------------------------------------------------------------------------------------------------------------------------------------------------------------------------------------------------------------	---------------------------------------------------------------------------------------------------------------------------------------------------------------------------------------------------------------------------------------------------------------------------------------------------------	---------------------------------------------------------------------------------------------------------------------------------------------------------------------------------------------------------------------------------------------------------------------------------------------------------------------------------------------------------	----------------------------------------------------------------------------------------------------------------------------------------------------------------------------------------------------------------------------------------------------------------------------------------------------------	--------------------------------------------------------------------------------------------------------------------------------------------------------------------------------------------------------------------------------------------------------------------------------------------------------------------------------------------------------------------------------------------------

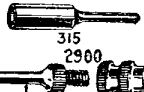
 <p>Microvern THE vernier dial for extra sharp tuning. No backlash. Special finish permits logging of stations on dial. Beautiful appearance. Comes in gold or silver finish. State which wanted. F3066 Microvern, any finish\$1.76</p>	 <p>Rasco 180° Variocoupler Silk wire wound on bakelite tubes. Six taps. Wave length, 150 to 600 meters. For panel mounting ¼" shaft. Your money refunded if it is not all we claim. F3160 Variocoupler prepaid\$1.05</p>	 <p>Copper Ribbon .0005" thick. F708 ¾" wide; F701 ¾" wide; F702 3-16" wide. All sizes per foot.\$0.01</p>	 <p>Rasco Clip Leads Invaluable for experimental work. Clip lead hooks in a jiffy onto any wire, binding post or conductor. Safest experimental connection. Brass clips, 1 foot silk wire, green or red. F7887 Clip Leads, ea. \$0.12 Dozen lot 1.35</p>	 <p>Adapter Patent Improved Adapter. Takes 109-type tubes. Fits standard 201A sockets. Phosphor bronze springs. Short circuits imposable. Bakelite milled. F6521 Adapter\$0.36</p>	 <p>PUSH-PULL Push Pull Transformer for many new circuits. See any radio magazine. Made of best materials. Coils impregnated. Silicon steel laminations. Save 50 per cent by assembling yourself. Simple instructions furnished. F1159 Push-Pull Transformer, ratio 6½ to 1 \$2.95</p>	 <p>Hard Rubber Panels Highest dielectric strength as per Bureau of Standards. Beautiful finish. F7100 7x18x3-16"\$0.65 F7120 7x12x3-16" 0.79 F7160 7x14x3-16" 0.89 F7180 7x18x3-16" 1.15 F7210 7x21x3-16" 1.31 F7240 7x24x3-16" 1.46</p>
-----------------------------------------------------------------------------------------------------------------------------------------------------------------------------------------------------------------------------------------------------------------------------------------------------------------------------------------------	---------------------------------------------------------------------------------------------------------------------------------------------------------------------------------------------------------------------------------------------------------------------------------------------------------------------------------	---------------------------------------------------------------------------------------------------------------------------------------------------------------------------------------------------------------------	--------------------------------------------------------------------------------------------------------------------------------------------------------------------------------------------------------------------------------------------------------------------------------------------------------------------------------------------------------------------	-------------------------------------------------------------------------------------------------------------------------------------------------------------------------------------------------------------------------------------------------------------------------------------------	------------------------------------------------------------------------------------------------------------------------------------------------------------------------------------------------------------------------------------------------------------------------------------------------------------------------------------------------------------------------------------------	-----------------------------------------------------------------------------------------------------------------------------------------------------------------------------------------------------------------------------------------------------------------------------------------------------------------------------------------------------------------------------------------------------

 <p>Low Loss Tuner Same type as used in our L.O.L.O.S. EXPLORER. Tuned from 200 to 600 meters. Hard rubber insulation throughout. Silver plated primary. Secondary D. C. C. Ticker silk insulated wire. F2890 Tuner\$5.00</p>	 <p>"T" Wire Connectors This big little article solves all troubles when making 6" wire connections. Made to take 1-18" square or round bus-bar wire. Can be attached with a pair of pliers. F2978 "T" Wire Connectors, 12 for\$0.10</p>	 <p>Nosolder Lugs Finally, a real solderless lug is here. Soldering positively done away with. Takes square or round bus bar, which it holds with a vise-like grip. Perfect connection. Just slide bus bars into slip-grip. F3727 Lug, 25 for \$0.20</p>	 <p>Low Loss Coil Same type as used in Freshman and other Tuned Radio Frequency sets. D.C.C. wire. 200 to 350 wave-length. 3" diameter. 1" wide, 5-16" thick 4 connections, 2 primary, 2 secondary. F2629 Low Loss Coil \$0.43</p>	 <p>Binding Post Strip Made of hard rubber, gold engraved lettering. Two nickel brackets for mounting. 7 hard rubber binding posts. "ANT", "GND", "A", "A+", "B", "B+", "DET B+", "AMP B+", F870 Binding Posts \$0.35</p>	 <p>Tinned Nickel Lugs All our lugs are tinned. F310 Brass Lugs for No. 8 screw, doz.\$0.10 F311 Copper Lugs for No. 8 and 9 screws, doz. \$0.10 F369 Copper Lugs for Nos. 4, 6 and 8 screws, doz. \$0.10 F308 Copper Lugs for 6-32 screw, doz. 0.10</p>	 <p>Battery Snap Switch This Switch is produced under high standards of workmanship. Action is positive. Solderless contact screws used. One-hole mounting. Nickel-plated all over. Most serviceable switch made. F7986\$0.36</p>
---------------------------------------------------------------------------------------------------------------------------------------------------------------------------------------------------------------------------------------------------------------------------------------------------------------------------------------	--------------------------------------------------------------------------------------------------------------------------------------------------------------------------------------------------------------------------------------------------------------------------------------------------------------------------------------------------	------------------------------------------------------------------------------------------------------------------------------------------------------------------------------------------------------------------------------------------------------------------------------------------------------------------------------------------------------------	--------------------------------------------------------------------------------------------------------------------------------------------------------------------------------------------------------------------------------------------------------------------------------------------------------------------------------------	------------------------------------------------------------------------------------------------------------------------------------------------------------------------------------------------------------------------------------------------------------------------------------------------------------------------------	--------------------------------------------------------------------------------------------------------------------------------------------------------------------------------------------------------------------------------------------------------------------------------------------------------------------------------------------------------------------------------	---------------------------------------------------------------------------------------------------------------------------------------------------------------------------------------------------------------------------------------------------------------------------------------------------------------------------------------------

 <p>Phono Plugs Sold from 50¢ to 65¢ everywhere. Hard rubber composition shell and patented cord tip holder. Finest workmanship throughout. F1030 Rasco Telephone Plug, Each\$0.23</p>	 <p>Bakelite Socket Octagon shape. Four nickel binding posts, phosphor bronze contact springs. Best brown bakelite. F6510 Bakelite socket \$0.40 F6500 Tube Socket. Made entirely of composition. Best made. Each. \$0.35</p>	 <p>Binding Post Name Plates Dia. ¾". These styles: Phone, Ground, Out, In, "A" Bat, "B" Bat, "C" Bat, "D" Bat, "E" Bat, "F" Bat, "G" Bat, "H" Bat, "I" Bat, "J" Bat, "K" Bat, "L" Bat, "M" Bat, "N" Bat, "O" Bat, "P" Bat, "Q" Bat, "R" Bat, "S" Bat, "T" Bat, "U" Bat, "V" Bat, "W" Bat, "X" Bat, "Y" Bat, "Z" Bat. F6600 Name Plates, Dozen\$0.15</p>	 <p>"Rasco" Posts Made of hard rubber composition. F650-51 Each\$0.06 F292 Has nickel plated bottom, each\$0.06 Dozen, each style,\$0.70 F122 Initialed Binding Posts. Set of 8. Per Set\$0.25</p>	 <p>Cord Tips Standard phono cord tips, nickel. F315 Each\$0.03 Separable Cord Tips No solder required. Wire goes in ferrule. Shank holds it tight. Nickel plated. F2900 Each\$0.66</p>	 <p>"Perfect" Lugs These new and improved lugs are brass, nickel plated, flattened on top as shown. Made of a single piece of metal. Lead wire goes into tube. F3110, F3080 "Perfect" Lugs, Each\$0.02 Dozen lots 0.20</p>	 <p>Brass Rods Sold in 6 lengths only. F8632 Red 8-32" thread length\$0.09 F8632 Red, 6-32" thread length\$0.06 F1425 Red, plain. ¼" round, length\$0.19 F8616 Red, plain 3-16" round, length\$0.06</p>
------------------------------------------------------------------------------------------------------------------------------------------------------------------------------------------------------------------------------------------------------------------------------------------------	-------------------------------------------------------------------------------------------------------------------------------------------------------------------------------------------------------------------------------------------------------------------------------------------------------------------------------------	------------------------------------------------------------------------------------------------------------------------------------------------------------------------------------------------------------------------------------------------------------------------------------------------------------------------------------------------------------------------------------------------------------------------------------------------------------------	------------------------------------------------------------------------------------------------------------------------------------------------------------------------------------------------------------------------------------------------------------------------------------------------------------------------------------------	---------------------------------------------------------------------------------------------------------------------------------------------------------------------------------------------------------------------------------------------------------------------------------------------------------------------------	------------------------------------------------------------------------------------------------------------------------------------------------------------------------------------------------------------------------------------------------------------------------------------------------------------------------------------------------	-------------------------------------------------------------------------------------------------------------------------------------------------------------------------------------------------------------------------------------------------------------------------------------------------------------------------------------------------

 <p>Roberts Coils Diamond weave coils, used in standard Roberts Circuit. Tuned 200 to 570 meters. Used in 2, 3, or 4 tube circuits. These are genuine Roberts Coils, not imitations. Set comprises two units, as illustrated. F-8112, Roberts Coils\$5.95</p>	 <p>100-Ampere Storage Batteries Guaranteed for two years. Only genuine material used. Genuine hard rubber case. Acid-proof terminals. Hard rubber vents. Strong carrying handles. Written guarantee goes with each. F8100. 6-cell 100-ampere hour battery \$9.50 Shipped express collect.</p>
-----------------------------------------------------------------------------------------------------------------------------------------------------------------------------------------------------------------------------------------------------------------------------------------------------------------------------------------------------------------------	------------------------------------------------------------------------------------------------------------------------------------------------------------------------------------------------------------------------------------------------------------------------------------------------------------------------------------------------------------------------------------------------------

New 1926 "Rasco" Catalog No. 15
CONTAINS 75 VACUUM TUBE HOOK-UPS, 300 ILLUSTRATIONS, 500 ARTICLES

All Armstrong Circuits are explained clearly, all values having been given, leaving out nothing that could puzzle you.

Just to name a few of the circuits: The V.T. as a detector and one-step amplifier; all Armstrong circuits; one-step radio frequency amplifier and detector; three stage audio frequency amplifier; short wave regenerative circuit; 4-stage radio frequency amplifier; radio and audio frequency amplifier; inductively coupled amplifier; all Rexco Circuits.

FREE

A POSTAL CARD BRINGS IT

 <p>Battery Lead Tags Latest wrinkle, made in metal, nickel-plated, polished. Clamp tag on battery wire, and it won't come off. These five styles: "B+", "A+", "Det.", "B-", "A-", and "A". F8030 Tags, set of 1050.15</p>	 <p>Rheostats and Potentiometers High heat bakelite base. Comes with tapered, knurled knob, 2 ½" dia. Complete with pointer. F4310 6 ohm\$0.38 F4311 30 ohm 6.44 F4312 Potentiometer 200 ohms 0.50</p>
--------------------------------------------------------------------------------------------------------------------------------------------------------------------------------------------------------------------------------------------------------------------------------------------------------------------------------	--------------------------------------------------------------------------------------------------------------------------------------------------------------------------------------------------------------------------------------------------------------------------------------------------------------------------------------

RADIO SPECIALTY COMPANY, 94S, Park Place, New York City

Factories: Brooklyn, N. Y. Eldridge, Md.

This New Magazine Will Increase Your Income!

VOL. I NO. 1. MONEY MAKING

MONEY MAKING

The Magazine of Opportunities
 Edited by Sidney J. Weinback



The CONSRAD COMPANY, Inc.
 NEW YORK

Money Making

Published monthly in the interest of ambitious men and women who want to become independent.

Covers every field of activity from which profit can be derived.

Explains the money-making possibilities in each particular enterprise.

Discusses definite steps to be taken by people adopting a means of livelihood, spare-time work, or a second income.

Has the following special departments:

- Prize Contest Record, a classified directory of current contests.
- The Literary Market, a record of periodicals for writers.
- Opportunities in New Patents, illustrating the latest promising inventions.
- Agents' Opportunities, describing attractive items for salesmen.
- Money-Making Formulas, with directions for preparing specialties.
- Cash Prizes for Money-Making Ideas, announcing the rules for our prize awards.

Publishes feature articles by recognized authorities in many fields, as, for instance, real estate, selling, writing, manufacturing, investments, speculation, farming the mail order business, decorating, candy making, needlecraft photography, mechanics, chemistry, window trimming and many others.

Subscription Price, \$2.50 the Year

SECURE A SECOND INCOME

Be independent in business—There are opportunities for big profits everywhere

MONEY MAKING is devoted to specific means and methods of increasing incomes. Hundreds of ways of making money in spare-time work are explained every month. Read MONEY MAKING and learn how.

25¢ ON ALL NEWSSTANDS

Ask your newsdealer for a copy to-day.

Published and Distributed by

The CONSRAD Company, Inc., 64 Church St., New York, N.Y.

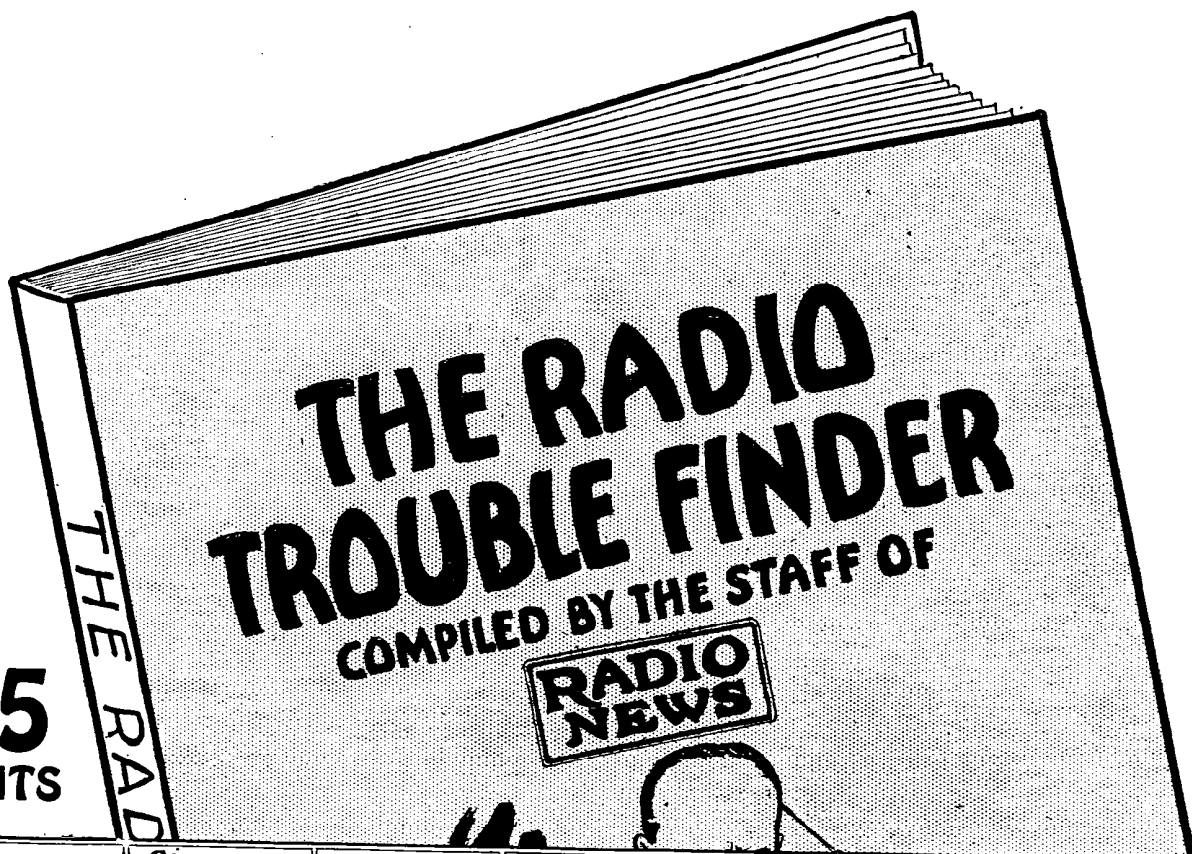

**25
CENTS**

THE RAD

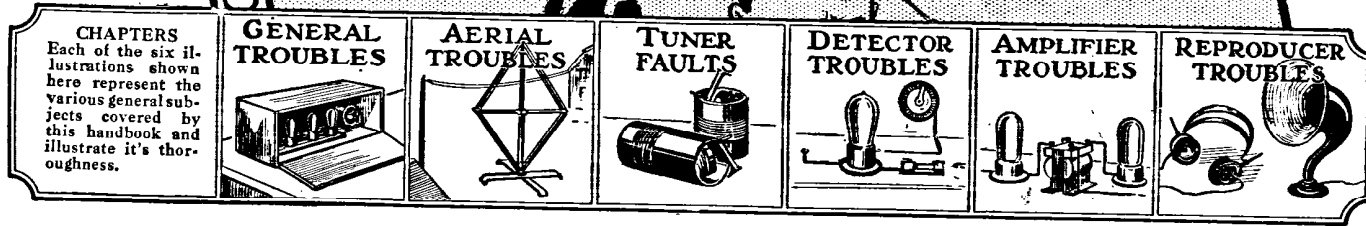

Trouble Finding and Correcting Simplified for Everyone

No matter how much or how little you know of your radio receiver, this new "Radio Trouble Finder" book is going to be a big help.

It explains the common and special faults of all the standard receivers of today; tells how to recognize instantly, by various sounds, where the trouble lies and also gives special simple tests by which you can determine what is wrong with your receiver. Then for each particular fault there is explained the proper procedure for correcting it.

All troubles and their remedies are arranged in simple charts so that even the most inexperienced radio user will have no trouble in keeping his set at all times in first class condition.

All parts of the radio set are illustrated to show the layman how to proceed in correcting faults.

THE PRICE OF THIS BIG BOOK IS ONLY 25c. Everyone can afford a copy. Keep one around the house for any emergency. Order today by using the coupon below, enclosing 25c.

Published by **The E. I. Company**
Distributed by

The Consrad Co., Inc., 64 Church St., New York, N. Y.

**68
Pages**

**200
Illustrations**

**Size
6 x 9 Inches**

**Sold everywhere
on Newsstands
and Radio Dealers**

CONSRAD CO., INC.,
64 Church St., New York, N. Y.
Gentlemen:—I am enclosing 25c. Kindly forward at once one copy of "The Radio Trouble Finder."
Name
Address
City, State

A TRIP to the CENTER of the EARTH

By JULIS VERNE

In his immortal story, "A Trip to the Center of the Earth", Jules Verne has quite outdone himself. Not only was Jules Verne a master of the imaginative type of fiction, but he was a scientist of high calibre. Besides this, his intimate knowledge of geography, the customs and peculiarities of the various races, made it possible for him to write with authority on any of these subjects. So when he takes us to the center of the earth, via the route through Iceland, we get the feeling that, somehow, the story is real, and this, after all, is the test of any good story.

Instead of boring a hole into the bowels of the earth, Jules Verne was probably the first to think of taking the reader to unexplored depths through the orifice of an extinct volcano. No one has as yet explored the very center of the earth, for at no time have we descended deeper than about a mile below the surface of the planet. Who knows, therefore, but that there may be tremendous discoveries ahead of the human race, once we penetrate into the great depths of the globe?

Even life in the interior of the earth is not an impossibility. When our deep sea expeditions come home with specimens of fish that live at the bottom of the ocean, and under what appear to be unendurable pressures, where logic would assume there could be no life. Read Jules Verne's story of "A Trip to the Center of the Earth", in the June issue of AMAZING STORIES, now on all newsstands.

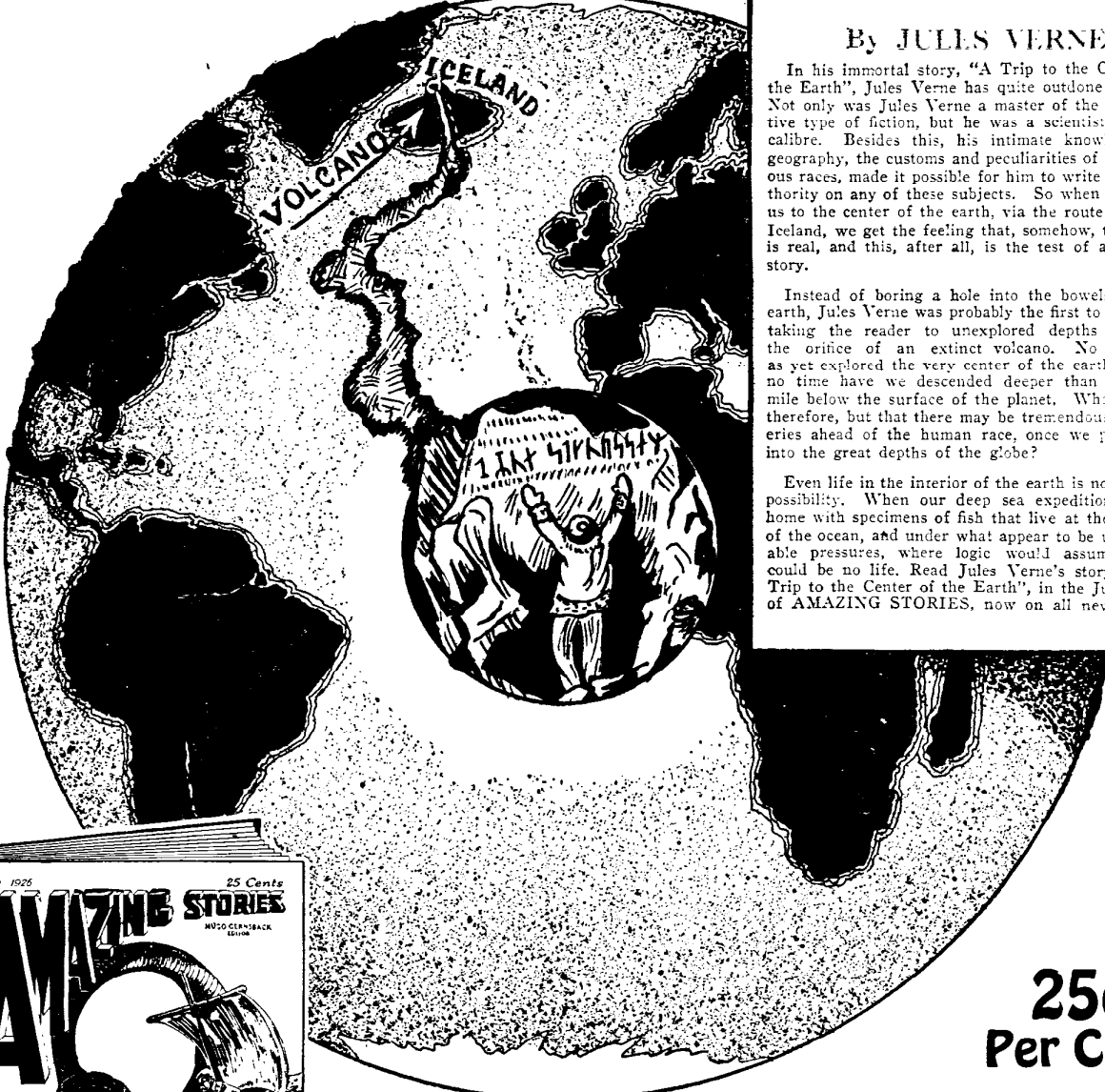

25c
Per Copy

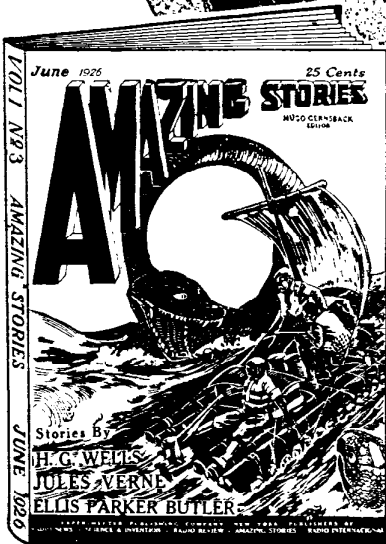

SCIENTIFICTION

A new kind of Magazine — Scientific Fiction Stories by world-famed writers

Marvelous, Amazing Stories by great men such as Jules Verne, H. G. Wells, etc., appear in this new magazine AMAZING STORIES every issue.

Stories of flying into space at dazzling speed on a comet; Mesmerizing the dead, remarkable situations of all kinds. Tremendously interesting—yet instructive.

Keeps you in touch with the writings of the men with the greatest imaginations in the world.

Don't miss a single issue—ask your newsdealer for a copy. Price is 25c. Large size magazine, 8 x 11 inches. Buy one today.

Experimenter Publishing Company, Inc.
53 Park Place, New York, N. Y.

YOU CAN BUY A COPY
ON ALL NEWSSTANDS
But if there is no newsstand
nearby, use this coupon

Experimenter Publishing Co., Inc.
53 Park Place, New York, N. Y.

Gentlemen: I am enclosing \$2.50 for
one year's subscription to "AMAZING
STORIES."

Name.....

Address.....