

101 Radio Hook-Ups

Compiled by the
Technical Staff of

**RADIO
NEWS**

1930 Edition

INCLUDING CIRCUITS ON

*Short-Wave Transmitters & Receivers,
Manufacturers' & Home-built Receivers,
Serviceman's Test Apparatus and a
Group of the New Loftin-White
Direct-coupled Amplifiers.*

PRICE

25¢

EXPERIMENTER PUBLICATIONS, inc. NEW YORK, N.Y.

Only
DURHAMS
are good enough
for the greatest
Names in Radio!



The new Precision Wire Wound Resistor for use where accurate, high value, non-inductive, low distributed capacity resistors are required.

Only DURHAMS should be Good Enough for YOU!

Today's leading set manufacturers attained their position by maintaining high reception quality—not by substituting lower priced parts. DURHAM Resistors and Powerohms have played no small part in creating the high standards which made them leaders. That's why the great majority of leaders standardize on DURHAMS...and why it will pay you to follow their lead! We shall be glad to send you engineering data sheets of the ratings in which you are interested.

Supplied in All popular types and values



DURHAM Metallized Resistances for every resistance purpose: 100 to 200,000 ohms in power types; 1 to 100 Megohms in resistor types; ratings for all limited range requirements; standard, pigtail or special tips.

DURHAM
METALLIZED
DURHAM
RESISTORS & POWEROHMS
INTERNATIONAL RESISTANCE COMPANY
1006 Chestnut St., Philadelphia, Pa.

101

Radio Hook-Ups

Prepared by the staff of

**RADIO
NEWS**



Vol. 1 No. 1
—1930 Edition—

Copyrighted by
Experimenter Publications, Inc.
1930

*All rights reserved, including that of translation in foreign languages;
including the Scandinavian.*



Published by
EXPERIMENTER PUBLICATIONS, INC.
381 Fourth Avenue, New York, N. Y.
Printed in the U. S. A.



WITH this comprehensive and very explicit little book we present the radio enthusiast with a cross-section of the progress made in this very interesting and important art.

No single radio development in recent years has received the attention now being given the Loftin-White System. It has provided us with a new, cheaper and better method of reproduction and one, which, from the standpoint of true radio and mechanical engineering, offers some very real possibilities.

Radio News magazine has the exclusive right to the publication of articles by Messrs. Loftin and White and we gratefully acknowledge the courtesy shown by Radio News in permitting their publication in this volume.

The choice of the circuits illustrated and described here cover almost every field of radio activity. They offer an ideal source of reference as well as an outline of progress which may well be followed to even greater achievement.

A handwritten signature in cursive script that reads 'Arthur H. Lynch'.

*Editorial Director
Experimenter Publications, Inc.*

R. T. I. R. T. I. QUALIFIES YOU TO MAKE MONEY AND ITS SERVICE KEEPS YOU UP-TO-THE-MINUTE ON THE R. T. I. NEWEST DEVELOPMENTS IN RADIO, TELEVISION AND TALKING PICTURES

RADIO
TELEVISION-TALKING PICTURES

TUNE IN ON R. T. I.

BIG MONEY NOW!

More to Come



Radio now offers ambitious men the greatest Money-Making Opportunity the world has ever seen! Hundreds of trained service men are needed by radio dealers, jobbers, and manufacturers!

A "trained" Radio "Service and Repair" man can easily make \$40 to \$50 a week, and it's very common for a "trained" man with experience to make \$75 a week, and up.

BIG MONEY for spare-time Radio Work is easily made in every city and village. You can now qualify for this Big-Pay work quickly through R. T. I. Get the Big Money Now and go up and up in this Big Pay field. The Radio industry calls for More Men, and R. T. I. supplies what the industry wants you to know.

Supervised by Radio Leaders

R. T. I. training is prepared and supervised by prominent men in radio, television and talking picture engineering; distributing; sales; manufacturing; broadcasting, etc. These men know what you must know to make money in Radio. You learn easily in spare time at home with the R. T. I. wonderful combination Testing Outfits, Parts, Work Sheets, Job Tickets. It is easy, quick and practical—covers everything in Radio—includes Talking Pictures and the latest in Television.

\$60—\$70—\$80—PER WEEK AND UP. That's what R. T. I. training leads to. Send for the R. T. I. Book.

No Experience Needed

ALL YOU NEED is the ambition and the ability to read and write. The Radio industry needs practical trained men. Remember, R. T. I. makes it easy to earn spare time money while you learn at home.

More to come

THE MEN who get into this Big-Money field now will have an unlimited future. Why? Because this billion dollar Radio industry is only a few years old and is growing by leaps and bounds. Get in and grow with it. \$10 to \$25 per week and more is easily made in spare hours while you are preparing for Big Money. TELEVISION, too, will soon be on the market, so the leaders say. Be ready for this amazing new money-making field. Remember, R. T. I. "3 in 1" home-training gives you all the developments in Television and Talking Picture Equipment, together with the complete Radio training.

Warning

Do not start R. T. I. training if you are going to be satisfied to make \$15 or \$20 per week more than you are now. Most R. T. I. men will make that much increase after a few weeks. There is no reason to stop short of the Big Money Jobs or the Big Profits in a spare time or full time business of your own. No capital needed. Get started with R. T. I. now. Make money while you learn at home.

R. T. I. Book Now FREE

The thrilling story of Radio, Television and Talking Pictures is told with hundreds of pictures and facts—its hundreds of big money jobs and spare time money-making opportunities everywhere. Send for your copy now. **USE THE COUPON.**



Let F. H. SCHNELL and the R. T. I. Advisory Board Help You

Twenty years Radio experience. First to establish two-way amateur communication with Europe. Former Traf. Mgr. of American Radio Relay League. Lieut. Com. U.S.N.R. Inventor, designer, consulting Radio engineer.

Assisting him is the R. T. I. Advisory Board, composed of men prominent in the Radio Industry. These men know Radio and will help you succeed in their field.

RADIO & TELEVISION INSTITUTE
Dept. 1034
4806 St. Anthony Ct. Chicago

RADIO & TELEVISION INSTITUTE
Dept. 1034, 4806 St. Anthony Court, Chicago
Send me Free and prepaid your **BIG BOOK** "Tune In On Big Pay" and full details of your three-in-one Home Training (without obligating me in any way).

Name _____
Address _____
City _____ State _____



THE R. T. I. ADVISORY BOARD. These men are executives with important concerns in the radio industry—manufacturing, sales, service, broadcasting, engineering, etc., etc. They supervise R. T. I. Work Sheets, Job Tickets, and other training methods.

R. T. I. R. T. I. TRAINS YOU AT HOME FOR A GOOD JOB OR A PROFITABLE PART TIME OR FULL TIME BUSINESS OF YOUR OWN



When You Build—Build WELL!



The World's Premier
Custom—RADIO
Perfected With

HAMMARLUND PARTS

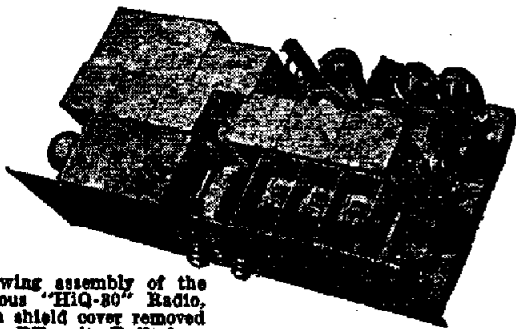

Showing assembly of the famous "HiQ-30" Radio, with shield cover removed from RF unit. Built in a few hours from completely-wired factory units.

THOUSANDS have built the new Hammarlund "HiQ-30" and call it "revolutionary."

It is in fact an amazing receiver—superb in design, perfect in parts, and delivers results that surprise even us.

Custom-Built with special Hammarlund units and backed by the twenty-year Hammarlund reputation for doing things right.

If you want the most sensitive and the most beautifully-toned receiver you have ever owned—build or have built for you the new "HiQ-30" Band-Filter, Screen-Grid Radio with six tuned circuits. *Mail coupon for complete information.*

HAMMARLUND MANUFACTURING CO.
424-438 W. 33rd Street, New York

For Better Radio
Hammarlund
PRECISION
PRODUCTS

HAMMARLUND MFG. CO., Dept. 161RH,
424-438 W. 33rd St., New York

Enclosed 25c (stamps or coin) for 48-page "HiQ-30" Manual. Please send folder on other Hammarlund Products.

Name

Address

3-STAGE BAND FILTER and R. F. AMPLIFIER UNITS

Completely wired, shielded and tested. Band Filter for 16-kilo-cycle selectivity. Flat-top tuning without side-band cutting. R. F. Amplifier with amazing amplification of 8 Screen-Grid tubes. Both units complete in every detail, except tubes, for immediate installation. Sub-panel connections.



New DRUM DIAL PANEL PLATE



Richly embossed, pebbled bronze, in the modern mode. It has grace and charm appropriate to the superb dial mechanism back-panel that delighted thousands of set builders last season. The control knob can be mounted anywhere on the panel. Illuminated scale.

AUDIO TRANSFORMERS

Including PUSH-PULL

Designed for fidelity of response over the audible frequency range with a sharp cut-off at the high frequency noise level. Large cross-section core of specially treated laminations permits high primary currents without saturation. Completely shielded. Pigtail terminal leads for sub-panel connection.



SHIELDED, POLARIZED R. F. CHOKE



A radio-frequency choke specially developed for modern high-gain, shield-grid receivers. Aluminum-shielded and polarized. Minimum external field. No undesired coupling to cause circuit instability or feed back. High inductance, low distributed capacity. Efficient, compact. Sub-panel connections.

The Famous "MIDLINE" CONDENSER

More than three years the favorite of engineers and advanced radio fans—and still new in the sense that its features and workmanship from the beginning were so far ahead that its popularity has steadily increased and its leadership still stands unchallenged. All standard capacities.

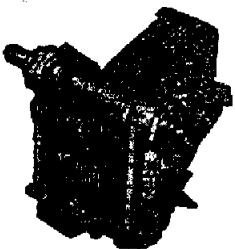

101 RADIO HOOK-UPS

CIRCUIT No. 1 is that of a crystal receiver using a tapped loose-coupler for tuning. In this circuit both the antenna and 'tuned' portion of the circuit is tapped permitting better selectivity than some of the simpler crystal radio receivers. Many types of crystals may be used as the detector or rectifier, two of the more common types

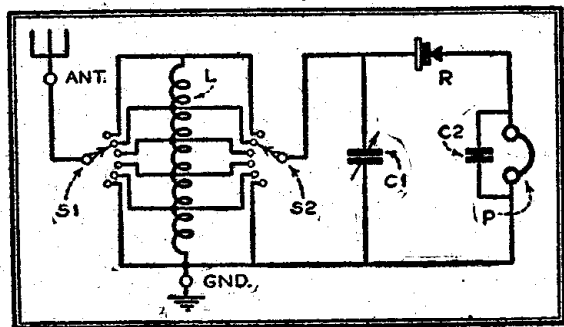

Circuit No. 1

however are, galena and carborundum. Crystal receivers may of course be constructed so that the primary and secondary circuits are separated. The secondary in such a circuit should be fixed, having the proper number of turns to tune over the desired wave bands when tuned by a variable condenser.

CIRCUIT No. 2 is that of one of the simplest of all circuits using the three-element tube, V1, as a detector or rectifier and a second tube, V2, in conjunction with an audio transformer, T1, as an amplifier of audio frequencies.

A fixed condenser C2 of .00025 mfd. capacity, is placed in the grid circuit between the grid of the tube and the inductance L1 and is known as a grid condenser. A grid leak, R1, is shunted across

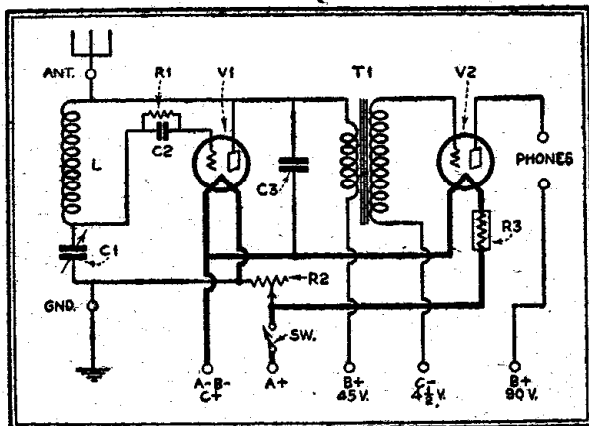

Circuit No. 2

the grid condenser and should be from 1 to 5 megohms in resistance. The usual bypass condenser, C3, is .001 mfd. and is connected across the primary of the audio transformer and the 'B' battery. A 'B' supply either a battery or 'B' eliminator is always used in a circuit employing the three-element tube. The voltage of this 'B' supply will depend upon the type of tube used. If a soft tube such as the -00 is employed, the 'B' potential will be between 16½ and 45 volts. With such a tube, when the rheostat R2, which in this case should have a resistance of 6 ohms, is turned up to a certain point, a slight hiss will be heard in the phones. For best results, the tubes should always be operated just under this hiss. The audio frequency amplifying tube, V2, should be the type of tube commonly known as "hard." Here the filament resistance, R3, is of the automatic ballast type. For audio frequency amplifiers voltages somewhat higher (90 volts)

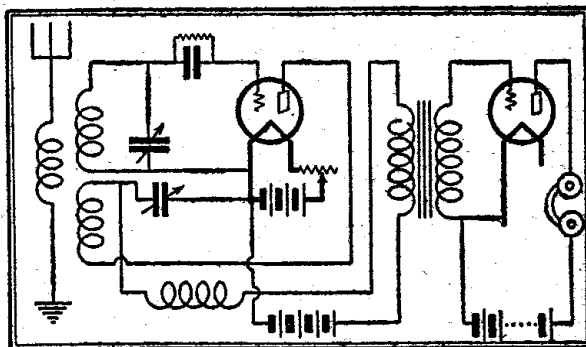

Circuit No. 3

than will be needed for the detector should be employed. To prevent distortion, a 'C' battery has been incorporated in this circuit.

Circuit No. 3. This circuit is somewhat similar to circuit No. 2 in that three-element tubes are employed as a detector and an audio frequency amplifier. In this circuit, however, better selectivity as well as better sensitivity is obtained by use of a separate primary or antenna coil and a fixed tickler tuned by a variable condenser. A radio frequency choke coil of 85 millihenries is shown in this circuit in series with the tickler coil and the primary of the audio frequency transformer, its function is to prevent the radio frequency

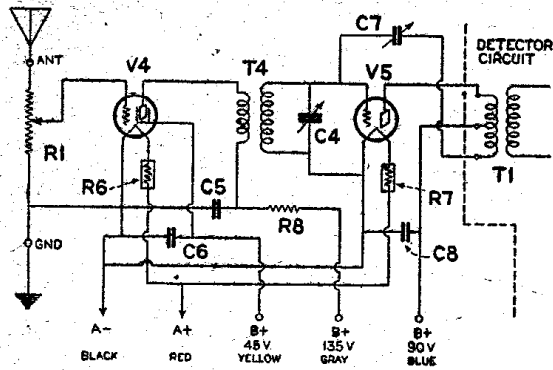

Circuit No. 4

currents entering the audio frequency amplifier thereby stabilizing the entire circuit. The tuning of a radio circuit of this type is extremely sharp. The close approach to the point of oscillation is evidenced by the fact that it does not spill over into oscillations as suddenly as in the case of nearly all regenerators. As the regeneration control condenser is increased, the amplification increases continuously, gradually working into the condition of oscillation. The approach is so close that both the incoming signal and the regenerative whistle can be heard at the same time when the tuning is very close.

CIRCUIT No. 4. To dwell at length upon the wonders of the neutrodyne receiver would be rehearsing an oft told tale. However, no series of circuits would be complete without one. The hookup shown in circuit No. 4 is the standard one invented by Professor Hazeltine, except that there has been added one stage of screen-grid as a blocking tube.

Do not try to force loud signals by using too much 'B' battery. Ninety volts is usually sufficient and no more should ever be used. The condenser shunted across the secondary of the neutraformer has 17 plates and by careful adjustment the dial reading of this stage as well as the detector will tune approximately alike.

CIRCUIT No. 5. In this hook-up the screen-grid tube as a blocking unit has been eliminated, so that now the first tube is a straight tuned neutralized stage followed by a regenerative detector and then two stages of transformer coupled audio frequency amplification with an output transformer, T5, protecting the windings of the loud speaker from burn out. The volume control for this circuit consists of

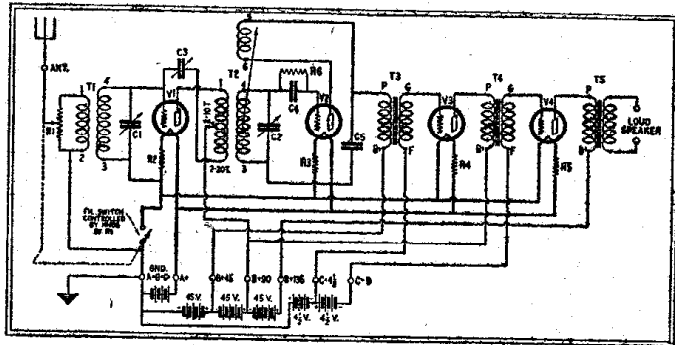

Circuit No. 5

a combination unit, a switch for turning the set on and off as well as a variable resistance controlling the signal value from the antenna. This volume control unit, variable resistance R1, should have a value of 25,000 ohms and is known as a potentiometer.

CIRCUIT No. 6. So much has been said

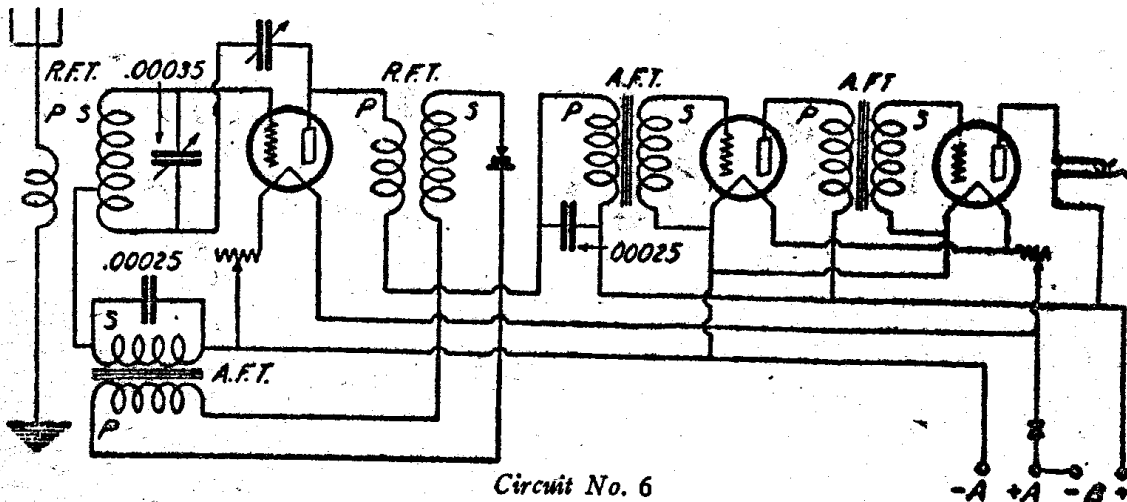

Circuit No. 6

about the popularity, low cost and faithful reproduction of the reflex circuit, that many people are beginning to realize its importance and are turning toward it. However, as there are so many reflex circuits it is often confusing to the layman as to just what circuit he should use. The Rasla reflex circuit as shown in circuit No. 6 is one of the simplest and most efficient receivers of this type it is possible to build.

By reference to the diagram, it will be noted that the antenna system is untuned of a semi-periodic nature. The circuit is

of a fixed detector, thus giving maximum transfer of energy and efficient coupling. A .00025 mfd. fixed condenser is shunted across the secondary of the audio frequency transformer which is used for reflexing. A 30-ohm rheostat is necessary for careful adjustment of the detector tube, while a 6-ohm rheostat will handle the audio frequency amplifier tubes very nicely.

CIRCUIT No. 7. For the fan who wishes a set that is stable and excellent for DX work, we can recommend the one shown in circuit No. 7. It is an English circuit

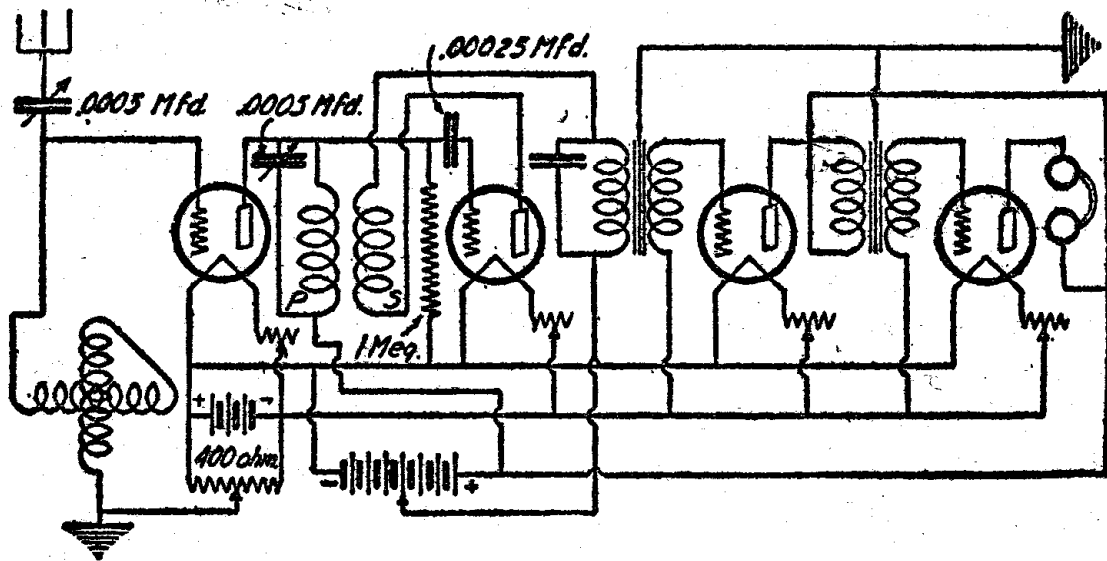

Circuit No. 7

tuned by a .00035 mfd. variable condenser of the low-loss type but as will be noted, only a part of the secondary coil is included in the grid circuit. A small balancing condenser tends to obviate the undesirable creation of oscillations and also serves somewhat as a volume control. Analyzing the circuit, we see it consists of one stage of tuned radio frequency amplification, a crystal detector, a reflex stage of audio frequency and two stages of straight audio frequency amplification.

The radio frequency transformer is one that is designed so that its impedance matches that

built entirely of standard parts. The variometer in the antenna circuit and the variocoupler that is used as a radio frequency transformer, should be of a high grade, for the proper functioning of the circuit is depended upon their quality. A 400 ohm potentiometer is used to place the correct grid bias on the radio frequency tube. The cores of the audio frequency transformers are shown connected

to ground, but this is optional. Connect the stationary plates of the condenser in the antenna circuit to the antenna binding post and those of the variable condenser across

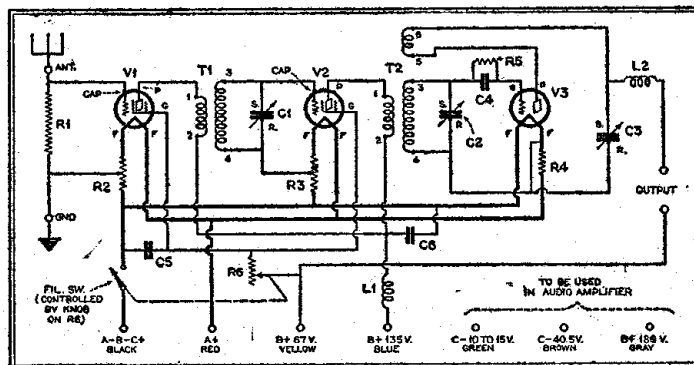

Circuit No. 8

the stator of the variocoupler to the plate binding post of the tube. UX-99 tubes will work very well in this set but it is recommended that UX-01A tubes be used for the best results. The audio frequency,

accomplished in a circuit of this type by the use of the choke coils of a radio frequency type, L1 and L2, and the by-pass condensers C5 and C6. The necessary 'C' bias for the battery-operated screen-grid

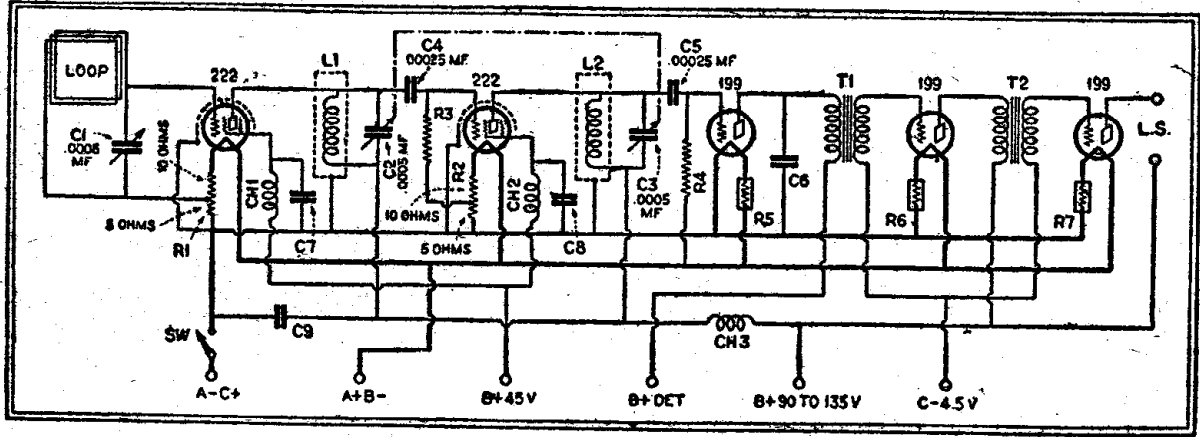

Circuit No. 9

transformers should have a ratio of 5 or 5½ to 1. At least 90 volts of 'B' battery should be connected to the plates of all tubes with the exception of the detector.

tubes is automatically obtained by the tapped filament resistors R2 and R3. The coupling device to the first tube R1, is a fixed resistor of the grid leak type and should be 10,000 ohms. For loud speaker reception, a standard audio frequency amplifier should be connected to the two output terminals. This circuit, as is however, will provide satisfactory earphone reception over reasonable distances.

CIRCUIT No. 8 is of two stages of radio frequency employing the new battery-operated screen-grid tube and a regenerative detector. In this circuit, the first screen-grid tube is used as a blocking unit and due to the extremely high amplification constant of this type of tube the signal is amplified before it reaches the radio frequency transformer, T1. Further amplification is provided in the second screen-grid battery-operated tube, V2, the signal is then rectified by the detector V3. This tube also being operated as a regenerative unit greatly increasing the sensitivity and selectivity of the receiver. Stabilization is

CIRCUIT No. 9 is especially suitable for use in a motor car or as a portable for locations where the signal pickup is necessarily poor. It is a five-tube circuit employing screen-grid tubes in the r.f. circuits and -99's for detector and audio. In the form shown, this receiver can be used with from 90 to 135 volts of 'B' and the total filament current required is just

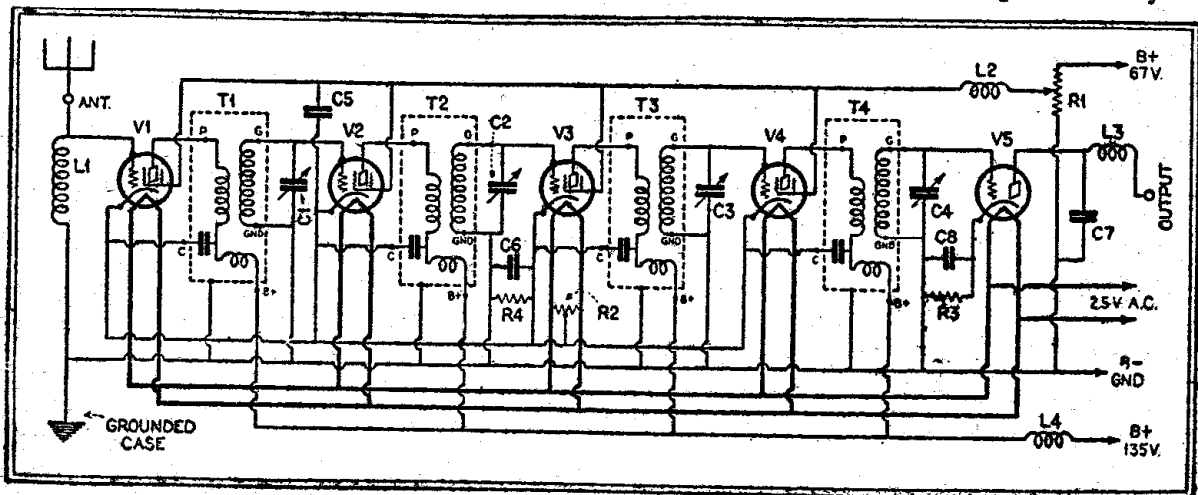

Circuit No. 10

under $\frac{1}{2}$ an ampere, permitting the use of a bank of dry cells if necessary, although the car storage battery is preferable. The advanced experimenter, of course, will instantly see the possibility of substituting the 120 tube in the second audio stage and it is perfectly feasible to use a screen-grid tube for the detector. Either one of these changes would only increase the filament current slightly.

CIRCUIT No. 10 is the National Velvetone 29 a.c. screen-grid tuner designed to work with a combined power pack and

the Arcturus a.c. 48 and V3 the Arcturus a.c. detector 26. The original Everyman tuner was designed for d.c. operation employing one stage of radio frequency amplification and regenerative detector, but here the circuit has been redesigned so that it now consists of two stages of radio frequency amplification and regenerative detector as well as using complete a.c. The circuit is extremely efficient in its pick-up and is of particular interest for its stability due of course to the generous use of radio frequency choke coils and bypass condensers. Of particular interest also

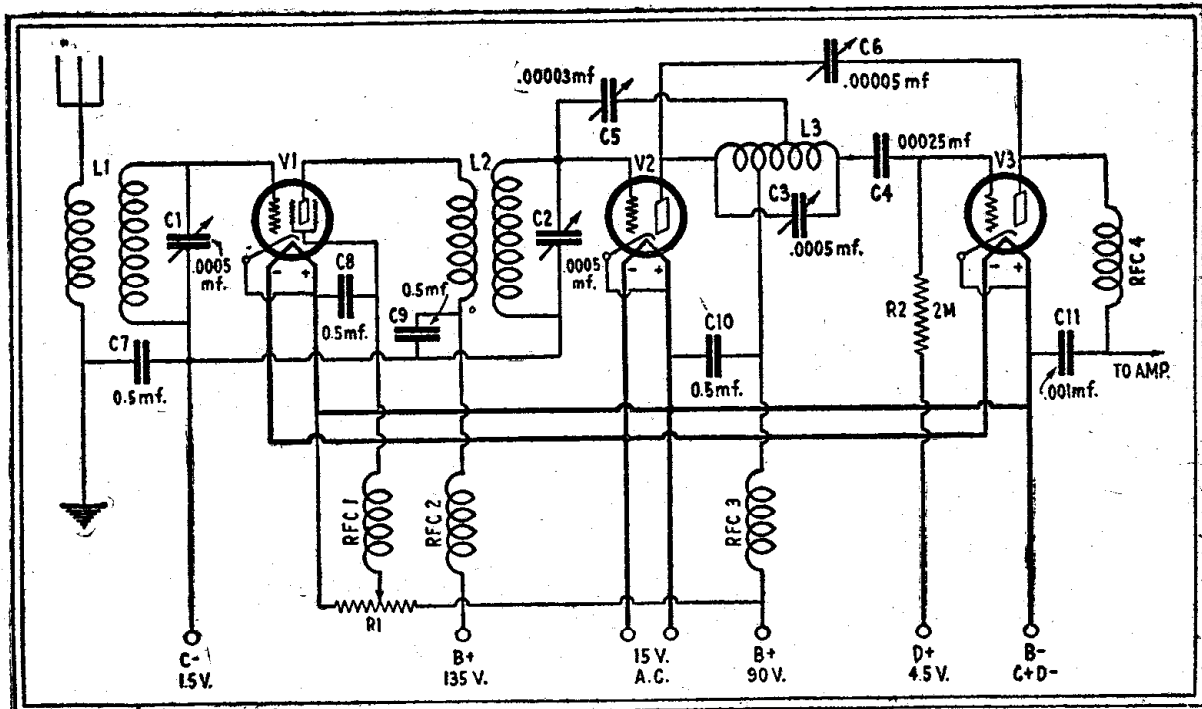

Circuit No. 11

amplifier. The tuner is obtainable in kit form. This circuit has shown splendid results in distance-getting in congested locations without sacrificing quality. It makes use of an untuned antenna stage, three tuned radio frequency stages (using four of the type -24 tubes) with a tuned detector input (gang for single control) feeding into the ordinary heater type a.c. tube as a detector. Note the stage shielding and the careful isolation of radio frequency circuits by choke coils and condensers.

CIRCUIT No. 11 is a schematic diagram of the well known Everyman tuner revised for operation with 15 volt a.c. tubes. These tubes are of the heater type, V1 being the Arcturus a.c. 22 screen-grid, V2

is that the primary and secondary of L1 are separated, thus necessitating a manual control of the variable coupling in place of the well known fixed coupling method. The inductance coils, L1, L2 and L3 are all wound on a 2-inch bakelite tube, the antenna primary of L1 consisting of 18 turns of No. 22 D.S.C., the primary of L2 is wound directly over the secondary of L2 and consists of 40 turns of No. 24 D.S.C., the secondaries of L1 and L2 consist of 70 turns of No. 22 D.S.C. while the coupler L3 is wound with 70 turns of No. 22 D.S.C. tapped at the 21st and 49th turns. The tuning capacities are as shown in circuit No. 11. The control R1 is a duplex clareostat while the radio frequency choke coils, RFC1, 2, 3 and 4 are the conventional 85 millihenry type.

While the Everyman tuner employs the regenerative detector, it must not be confused with the ordinary blooper circuit, as here we have two radio frequency tuning stages to prevent radiation in the antenna system. The regeneration is controlled by the small capacity C6. To the Everyman tuner may be added an audio amplifier using 15 volt a.c. tubes.

CIRCUIT No. 12 is a schematic diagram of a single control socket-powered receiver of unsuppressed tone quality and extraordinary amplification. Although the circuit is similar to many other tuned radio frequency circuits, the feature of the circuit is shown in the adequate by-passing and shielding to prevent interstage coupling. Also in this circuit will be noted the use of the screen-grid tube as a coupling medium between the antenna and first r.f. circuit. This allows single control of the tuning and is absolutely necessary to prevent antenna capacity being impressed on the first tuned circuit, causing a wide variation in the capacity of this circuit between the wavelength of 550 and 200 meters.

The inductances, T1, T2, T3, T4 are wound on "air" bakelite forms and are designed for use with the tuning capacities C1, C2, C3 and C4. The tuning condensers are of the battleship type well known for their sturdy construction. Of particular interest is the resistance coupled amplifier where hi-mu tubes are used in the first and second stages with a power tube of either -71 or -45 type in the last stage. Here a plate audio choke is used with a by-pass condenser (more commonly known as the tone control) for protecting the speaker windings from the high d.c. current. The plate resistances in the amplifier are in the order of 100,000 ohms each, while in the first two stages the grid resistors are 500,000 ohms with a grid resistor in the power tube stage of 250,000 ohms. In each of the positive filament circuits are inserted amperites of the correct resistance value to correspond with the type of tube used. In some extreme cases, it may be found necessary, due to oscillation, to insert grid suppressors between the tuning inductance and the grid of each tube at point marked "X" as

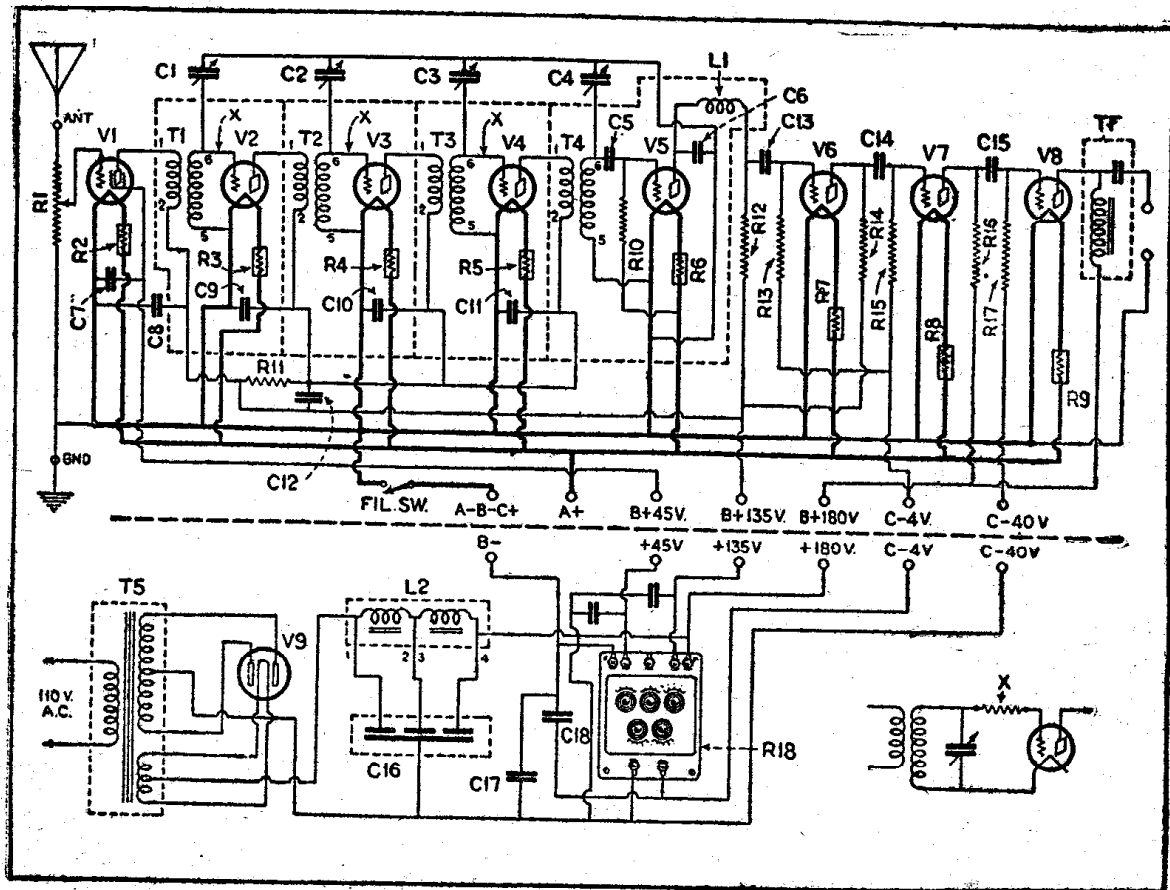

Circuit No. 12

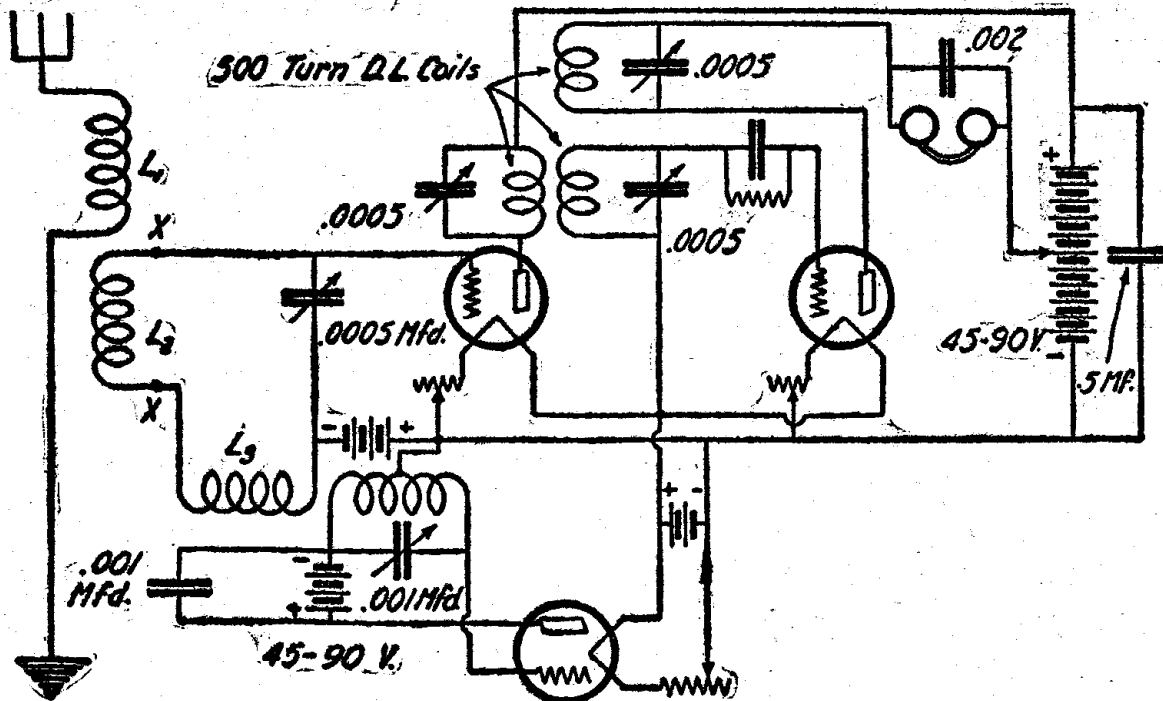

Circuit No. 13

shown in circuit No. 12. These grid suppressors are wire-wound resistors manufactured in a convenient form. The resistance wire is wound on a core covered with insulating material and the whole is encased in cambric cloth. Eyelets are located at the ends of wire for ease of connection. The 'B' and 'C' power pack for this circuit is of the conventional -80 rectifier tube with its associated filter circuit, comprising of condenser pack C16 and 'B' eliminator choke L2. A standard manufactured voltage dividing device, R18, is used for obtaining the various values of plate and grid voltages for the operation of the circuit. By-pass condensers are also connected across these various taps.

CIRCUIT No. 13. Many fans are anxious to experiment with the superheterodyne circuit but the expense of the equipment has prevented them. In circuit No. 13 is shown a diagram that has for its principle the superheterodyne method and the parts are relatively inexpensive. The constants of the coils are as follows. No. 20 D.C.C. wire is used for winding all the coils. L1 is 5 turns on a 4-inch tube, L2 is 35 turns on the same tube, starting $\frac{1}{4}$ of an inch from L1. L3 is 4 to 8 turns on a 3-inch tube and L4 is 27 turns on the same tube, the latter wiring being tapped at the 13th turn. The three honeycomb coils in the plate circuit of the two tubes should be placed in a regulation mounting so that

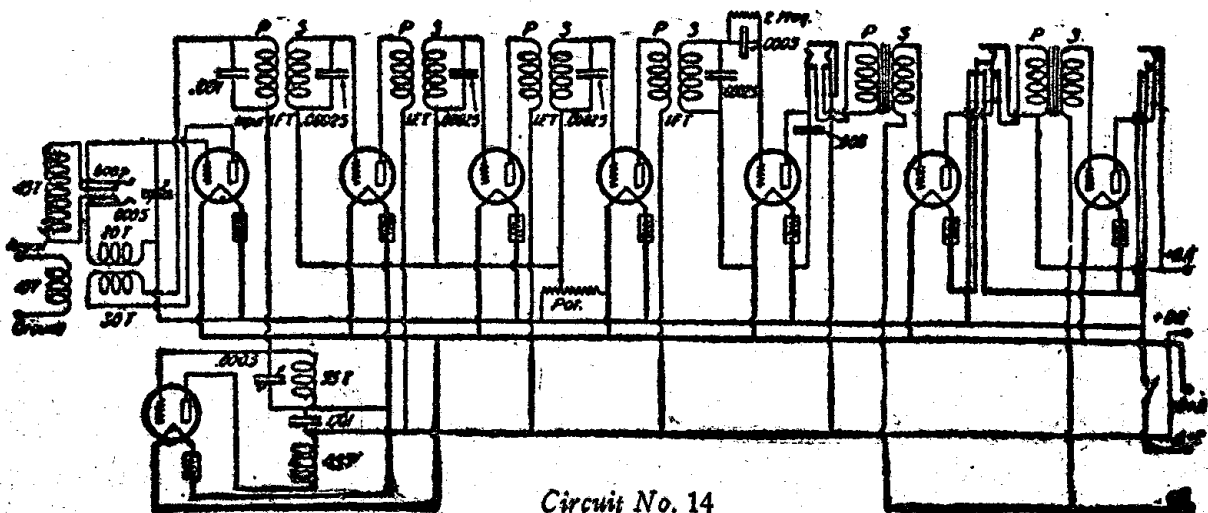

Circuit No. 14

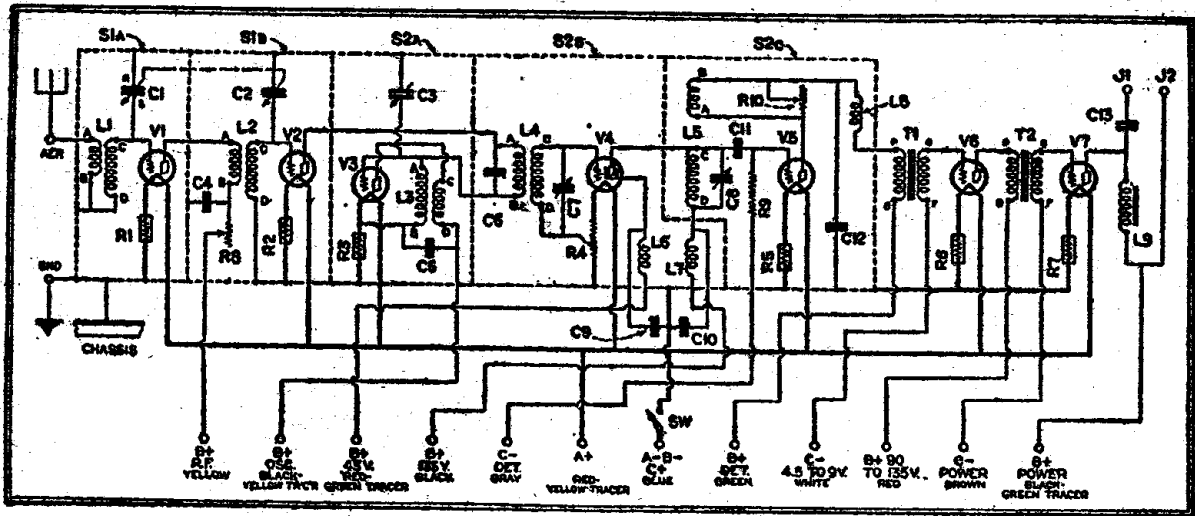

Circuit No. 15

their inductive relationship may be varied. If a loop is used with this circuit, it is connected in the places marked "X" thereby eliminating the primary and secondary windings of L1 and L2. The set is tuned by a .0005 mfd. condenser across the secondary and a .001 mfd. condenser in the oscillator circuit. The three .0005 mfd. condensers are shunted across the honeycomb coils, needing very little adjustment after once being set.

The tuning of this circuit is not very difficult. Place the .0005 mfd. variable condenser in the L2, L3 circuit at a low scale reading and slowly turn the .001 mfd. variable condenser which controls the oscillator circuit until a hissing noise is heard. If no signals come in at this read-

ing, raise one or two degrees and retune the oscillator circuit condenser until the hissing is again heard. This is continued until signals are heard.

CIRCUIT No. 14. In the circuit shown here, there is incorporated a different system of producing beat notes than that employed in any other superheterodyne radio receiver. Amperites instead of rheostats are used throughout. The 200 to 400 ohm potentiometer

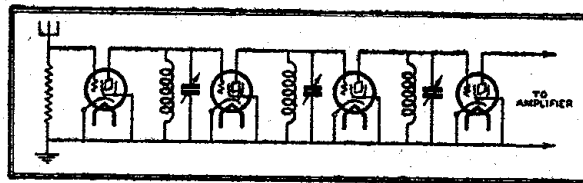

Circuit No. 16

shown is used to give the proper grid bias to the intermediate frequency tubes. It is hardly necessary to say that the apparatus should be so placed that leads may be as short as possible. This circuit as shown consists of two stages of transformer

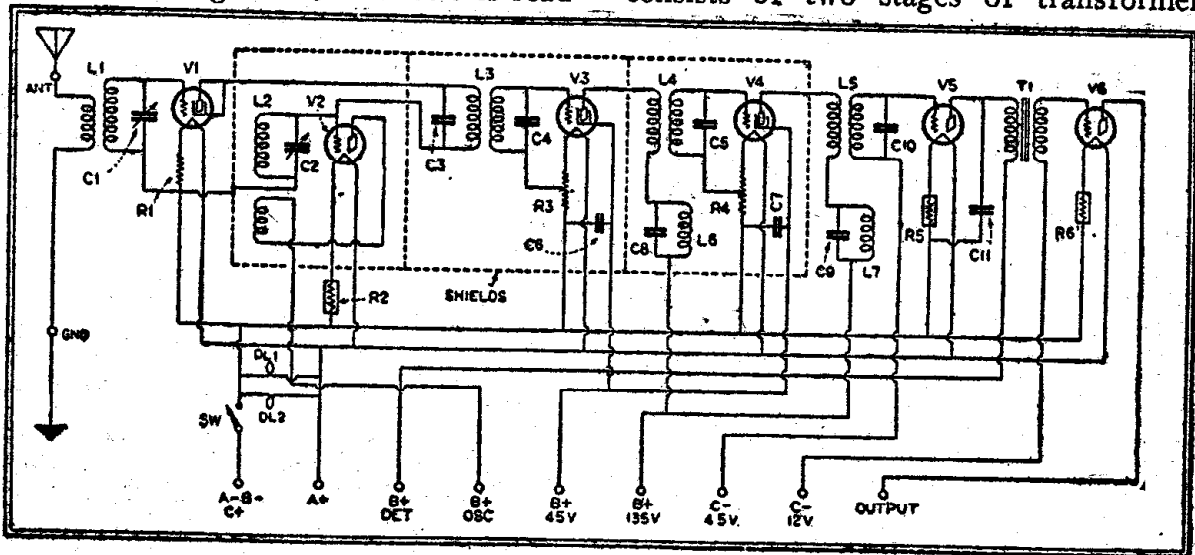

Circuit No. 17

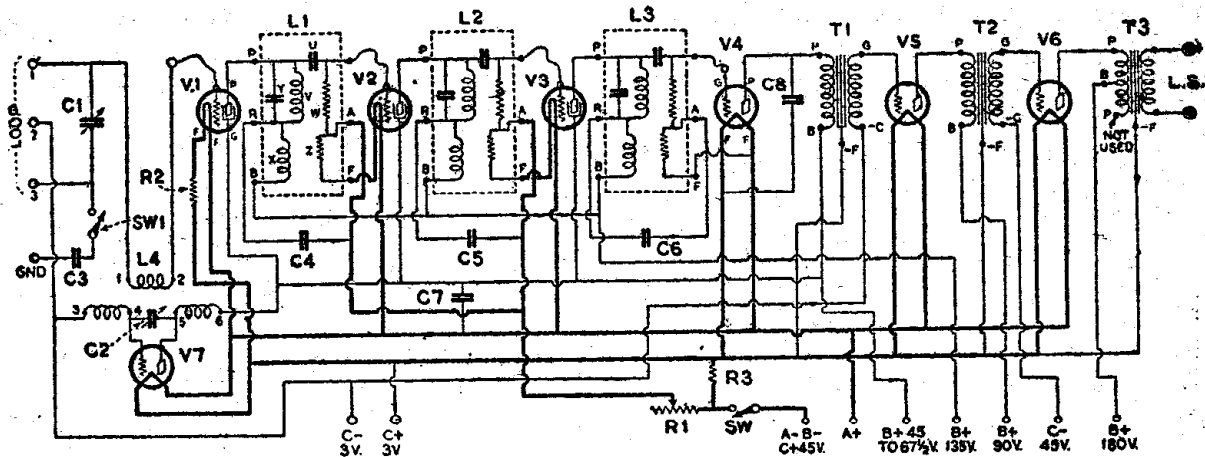

Circuit No. 18

coupled audio amplification but by the use of jacks, signals may be taken directly from the plate of the detector tube or using one stage of audio frequency amplification.

CIRCUIT No. 15 is that of the popular and efficient superheterodyne receiver designed for the home constructor. It makes use of individual stage shielding and a metal subpanel. The single stage of intermediate frequency amplification using a screen-grid tube is equivalent to more than two stages of the ordinary type, while the additional stage of tuned radio frequency ahead of the first detector adds both selectivity and sensitivity. The shield cans and metal chassis save a great deal of wiring in making the construction an easier and quicker job. By a slight re-vamping, this circuit would also be suitable for use with a.c. tubes.

CIRCUIT No. 16. Recently the band-pass filter has come into its own, due of course to the number of high-powered broadcasting stations operating with very little separation. The band-pass filter shown in cir-

cuit No. 16 can be used either as a pre-tuning stage for a superheterodyne or a tuned radio frequency. The circuit is shown with a.c. screen-grid tubes so that a very high degree of sensitivity is obtained along with the selective feature such a circuit provides.

CIRCUIT No. 17 is that of the RE-29, the late R. E. Lacault's last contribution to the greater efficiency of the radio receiving circuits, incorporating the designer's well known frequency changing system (the Ultradyne). It is brought entirely up to date by the use of tubes throughout, three of these being of the screen-grid variety while the oscillator, second detector and first audio tubes are of the three-element type. The output of this circuit may be operated as is for medium distance but for extremely loud signals and greater distance should be fed into a stage of push-pull audio frequency amplification consisting of a pair -45 tubes.

CIRCUIT No. 18 gives the schematic details of the well known Tyrman shield-

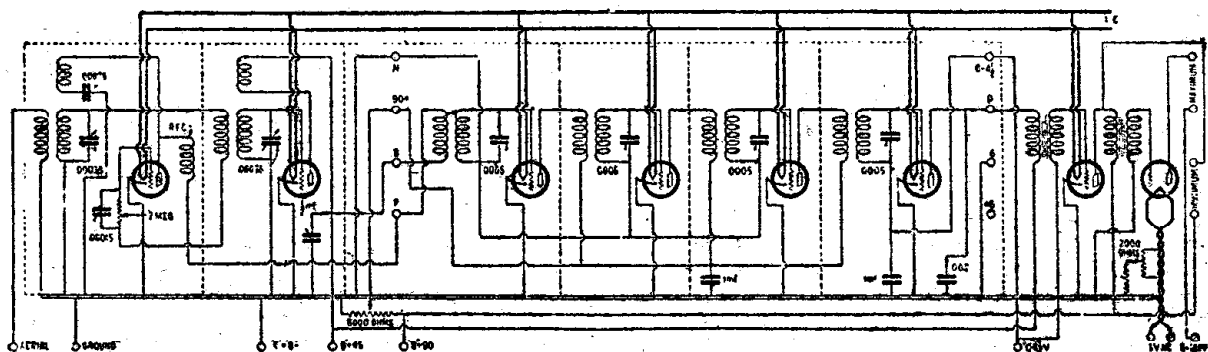

Circuit No. 19

grid 7. This is a superheterodyne circuit utilizing a screen-grid tube as the first detector followed by two screen-grid intermediate frequency amplifiers, each stage being carefully shielded. The receiver employs a loop and is designed to operate from a d.c. filament supply, with the power pack capable of supplying the plate potential of 180 volts for the -71 output tube.

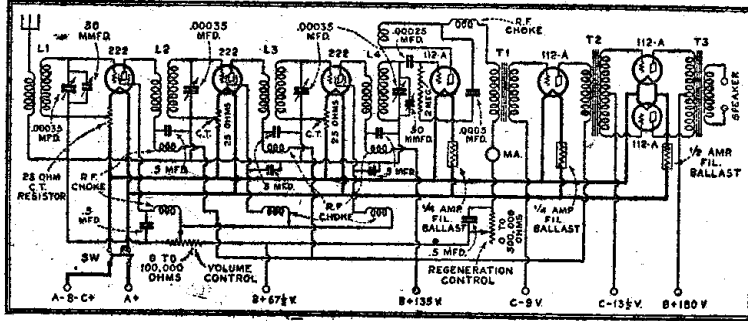

Circuit No. 20

CIRCUIT No. 19. Schematic diagram of a superheterodyne using the Silver Marshall time signal amplifier as an intermediate frequency amplifier, is here shown as adapted for operation with heater type a.c. tubes. The power tube of the -71 type is operated from the 5-volt secondary of the heater transformer. The grid bias for this tube is obtained automatically through a resistor. Although the a.c. leads to the heater type tubes are shown in this diagram in heavy straight lines, it should be remembered that all a.c. leads should be of twisted wire.

CIRCUIT No. 20 is a schematic diagram of a three-stage tuned radio frequency amplifier employing the d.c. screen-grid tubes and -12A tubes as a regenerative detector, a first audio stage of transformer

coupled and a push-pull stage. Single dial control is permitted with a circuit of this type by making use of small compensating condensers of 50 mmfd. capacity across the tuning circuits of the first radio frequency stage and the detector stage. C bias for the radio frequency tubes is automatically obtained by the use of center-tapped resistors in the negative battery lead. Complete stabilization is effected by the generous use of radio frequency choke coils and .5MFD by-pass condensers in both the plate and screen-grid circuits of each of the radio frequency tubes. Volume is controlled by a potentiometer, its value being from 0 to 100,000 ohms, connected in the screen-grid circuit of the three radio frequency tubes. The -12A detector tube is made regenerative for better sensitivity and selectivity, regeneration being controlled by a variable resistor of 0 to 500,000 ohms by-passed by a .5MFD by-pass condenser. Visual tuning is incorporated in this circuit by making use of a milliammeter in the plate circuit of the detector. A circuit of this type may be laid out by the constructor to require a very small space, permitting its use as a portable unit for use in a motor car, motor boat or airplane.

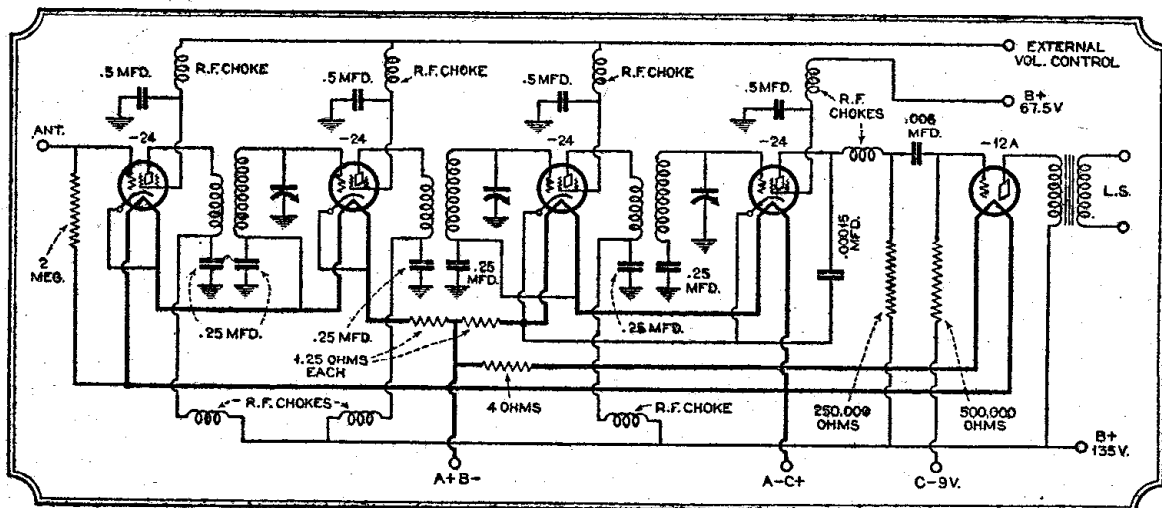

Circuit No. 21

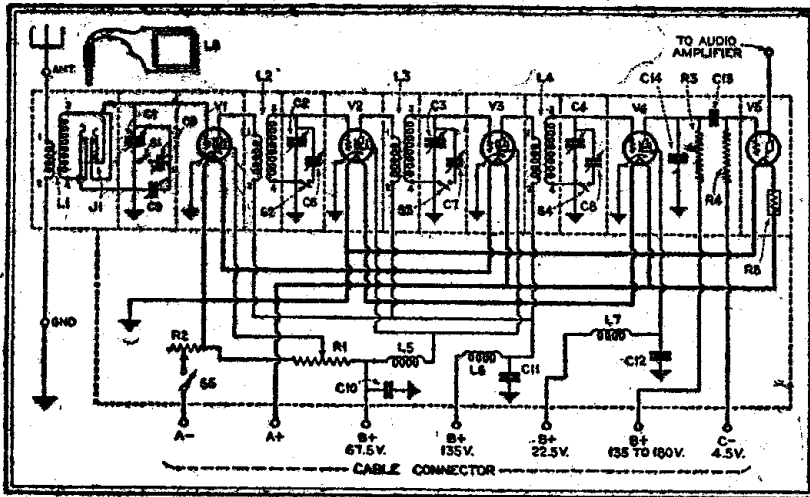

Circuit No. 22

and plate circuits of each of the a.c. screen-grid tubes.

Circuit No. 22 is that of a receiver especially designed for use on small motor boats. The a.c. screen-grid tube with its indirect heater is used in this circuit so that vibration from the engine or rough weather as well as battery variations would have no effect on the output signal. Provision was also made for tuning this

Circuit No. 21 is the circuit diagram of a radio receiver ideally suited for motor car work. Three stages of radio frequency amplification make use of the a.c. operated -24 screen-grid tube as well as a tube of a similar type in the detector stage followed by a stage of resistance coupling and a -12A tube as an audio frequency amplifier. Making use of the -24 a.c. heater type screen-grid tube is ideal for motor car

receiver in both the broadcast band of from 550 meters to 200 meters and the radio beacon band of 1,000 to 700 meters by use of single circuit switches S1, S2, S3, S4, inserting additional capacities, C6, C7, C8, C9. To complete the radio beacon direction finding equipment, a double circuit jack was incorporated in the grid circuit of the first tuned radio frequency tube, permitting the use of a loop antenna.

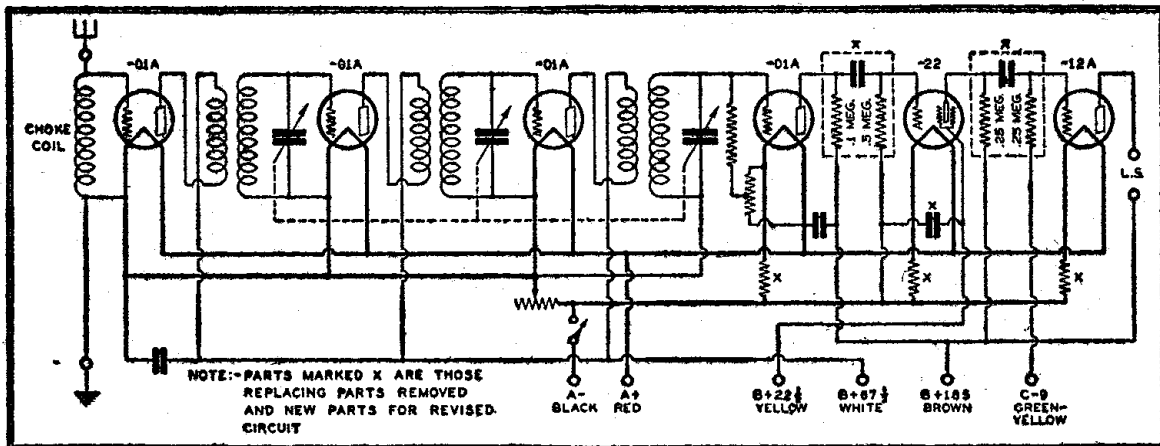

Circuit No. 23

work, due to the sturdy construction of the heater of this tube, eliminating entirely microphonic noises due to jars or sudden shocks. Sudden filament variations also have no effect on the output signal as there is a time limit in the cooling of the heater sleeve in such tubes. Single dial control is accomplished by using the first screen-grid tube as a coupling unit to the antenna circuit. Oscillation and unstable signals are entirely eliminated by the use of radio frequency chokes and .5MFD by-pass condensers in both the screen-grid

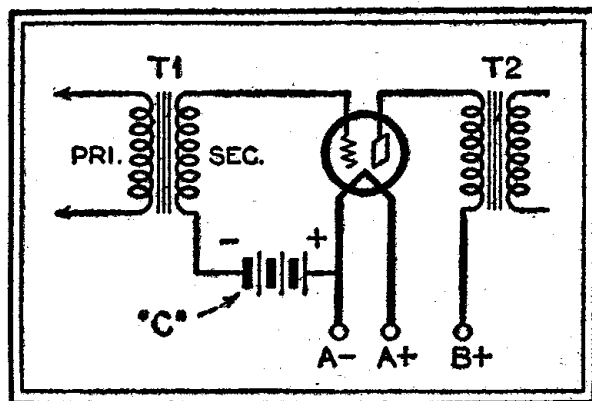

Circuit No. 24

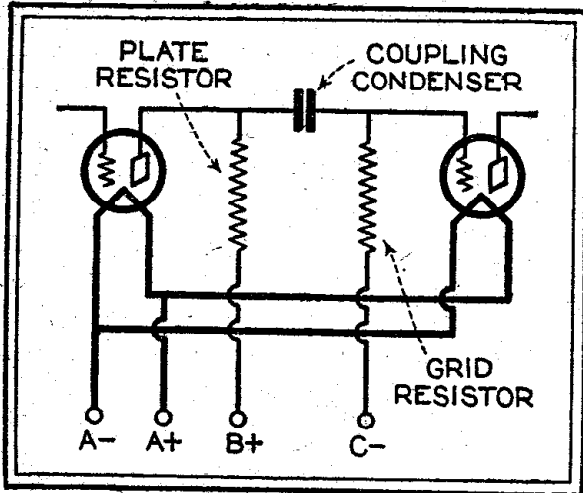

Circuit No. 25

Each stage of this circuit was completely shielded, so that with the use of spark plug and distributor head resistors, the elimination of engine interference was effected. For good loud speaker reception, it is necessary to use an additional stage of audio frequency amplification which was built up as a separate unit. The resistor R1, a potentiometer of 100,000 ohms, served as the volume control and varied the screen-grid voltage of the first radio frequency tube V1.

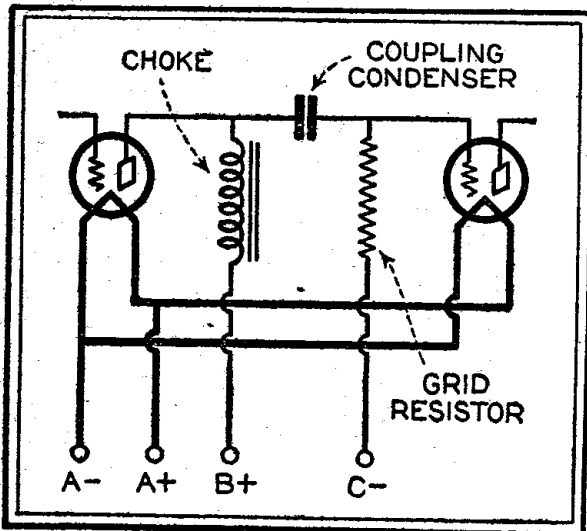

Circuit No. 26

CIRCUIT No. 23 is of the standard At-water Kent tuned radio frequency receiver in which the audio frequency amplifier has been revamped to resistance coupling employing a battery-operated screen-grid tube in the first stage and a -12A tube in the second or output stage. This receiver was revamped so that it may be used as a

motor car receiver using standard parts now readily obtainable on the open market. Single dial control is accomplished by the use of a blocking tube stage using the -01A tube connected in the antenna circuit in conjunction with a small radio frequency choke coil. A material increase in volume was obtained by the use of the screen-grid resistance-coupling stage.

CIRCUIT No. 24 is a schematic diagram of a one stage audio frequency amplifier employing transformer coupling. Here

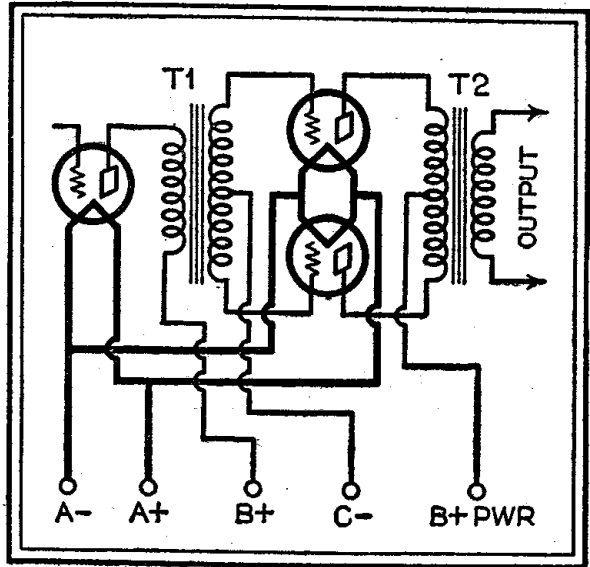

Circuit No. 27

T1, the input transformer, should have a ratio of $3\frac{1}{2}$ to 1 while the output transformer T2 in the plate circuit of the tube if coupled to a succeeding tube, will require a ratio of 4 to 1, or if as a coupling device to a magnetic loud speaker, about

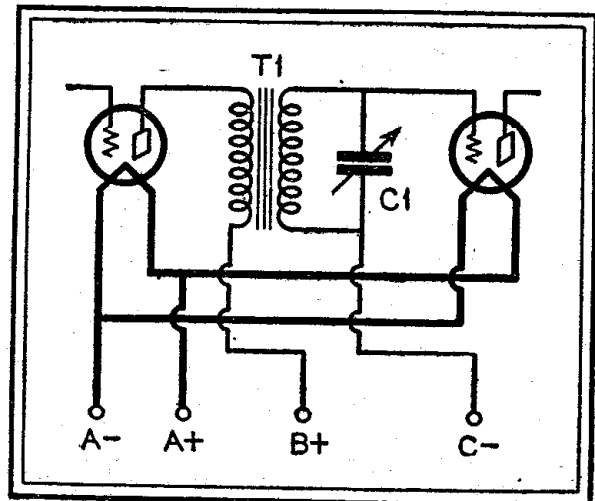

Circuit No. 28

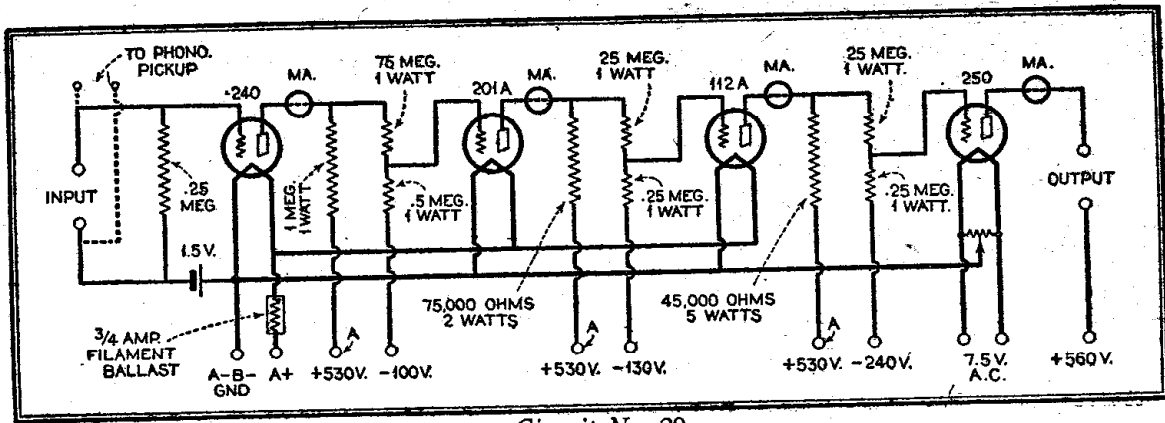

Circuit No. 29

1 to 1 ratio. To prevent distortion entering in an audio frequency amplifying stage of this variety, a C battery is employed to prevent positive grid swing. The standard transformer audio frequency amplifying system usually makes use of two stages employing this identical circuit.

CIRCUIT No. 25 is that of a stage of resistance coupling audio amplification. Here the plate of the preceding tube is coupled to the B power supply through a plate resistor, its resistance depended on the type of tube employed. A coupling condenser also depended on the type of tubes used, separates the plate supply and the grid supply of the succeeding tube. A grid resistor of the grid leak type, whose value is usually from 500,000 to 2 megohms, provides C bias to the grid of the second tube. The general feeling has been and rightfully so, that resistance coupling provides excellent quality, its one disad-

vantage being, very little amplification other than that obtained from the tube itself, will result requiring at least three stages of this type of audio frequency amplification.

CIRCUIT No. 26 is that of an impedance coupled audio amplifying system. Here an audio choke coil replaces the resistor in the plate circuit of the resistance-coupled amplifier. The coupling condenser and grid resistor will, of course, here depend on the type of tubes used. In many cases, this type of audio frequency amplifier is preferred to that of the resistance-coupling shown in circuit No. 25 due to its ability to give some amplification over that obtained from the amplification of the tubes themselves. It is usual, however, to use at least three stages in this type of an audio amplifier.

CIRCUIT No. 27 is a schematic diagram

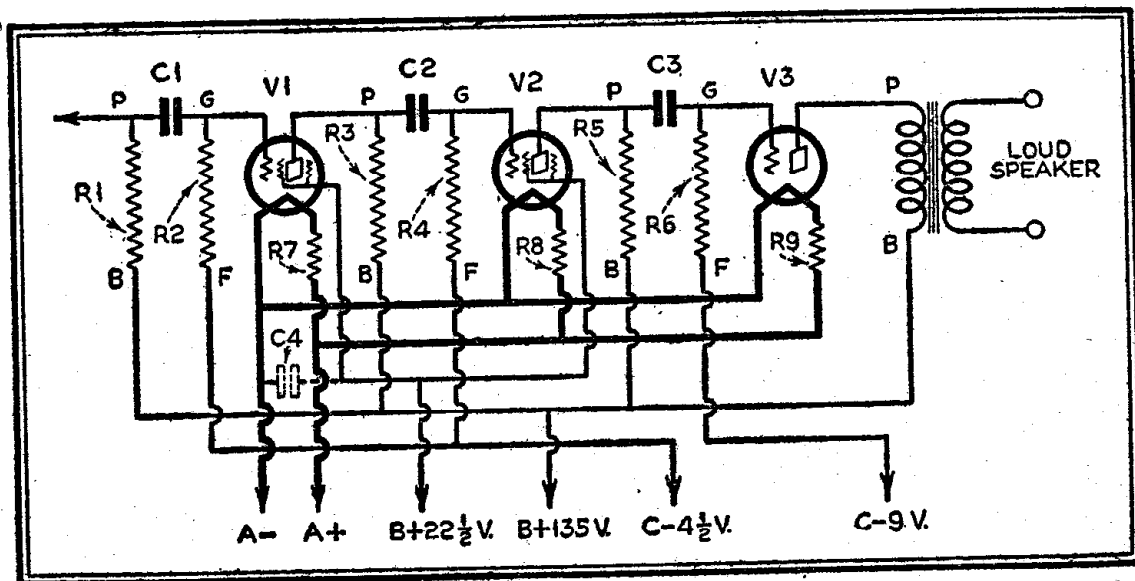

Circuit No. 30

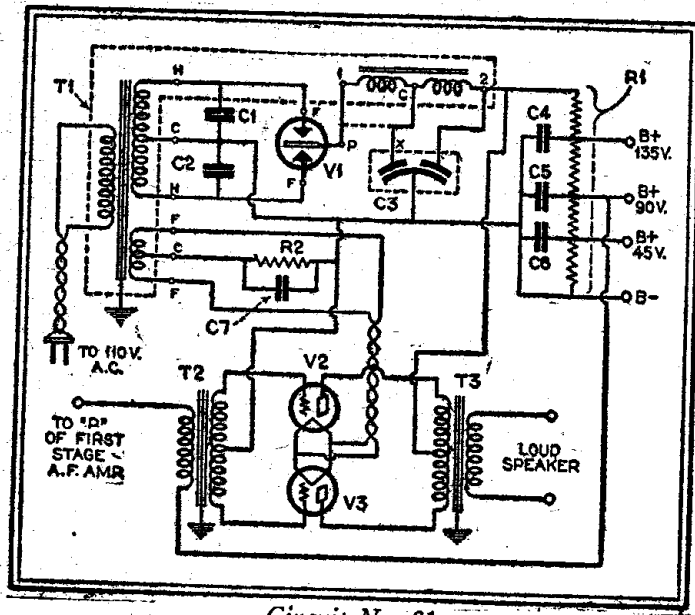

Circuit No. 31

of a push-pull audio frequency amplifier generally used as an output stage. Here the secondary of the input transformer has two complete secondaries, which are connected to the grids of a pair of tubes, their centers being the grid return to minus C. The primary of the output transformer is also made up of two units, being connected to the plates of tubes and the center tap returning to the B plus power. Two types of this transformer are now available, one for coupling directly to the magnetic speaker, in which case the ratio of the primary and secondary is approximately 1 to 1, the other for the dynamic speaker in which the primary usually has at least 80 turns to 1 of the secondary. Such a system as this will handle large amounts of undistorted volume and is now universally accepted in the commercial broadcast receiver as well as the theatre talking picture amplifier.

CIRCUIT No. 28 is that of a transformer audio amplifier where the secondary of the transformer is tuned. A system of this type is of little value in broadcast receiver but is mainly used by commercial and amateur code operators to obtain a very definite peak, entirely eliminating unwanted signals and other interference.

CIRCUIT No. 29 is a schematic diagram of one of the latest resistance-coupled amplifying systems, where enormous amplification is required. This type of amplifier may be used as an output device for a radio receiver or as an amplifier in conjunction with a phonograph pick-up. It will be noticed, however, that high voltages are required for both the plate and grid potentials. A noteworthy feature of this circuit is the absence of coupling condensers, their place being taken by resistors.

CIRCUIT No. 30 is that of a resistance-coupled amplifier employing as the amplifying tube the battery-operated screen-grid type tube. Due to the very high amplification constant of the screen-grid tube, a large amount of output volume is obtained from this system. This type of amplifier will work extremely well in conjunction with photoelectric cells for either television or talking movies. The frequency curve is reasonably flat.

CIRCUIT No. 31 is a schematic diagram of a B and C supply for the push-pull audio output stage shown and the B potentials for a radio receiver. Full-wave rectification is accomplished here by the use of a gaseous rectifier tube. The filter portion of this circuit consists of two audio frequency choke coils of the con-

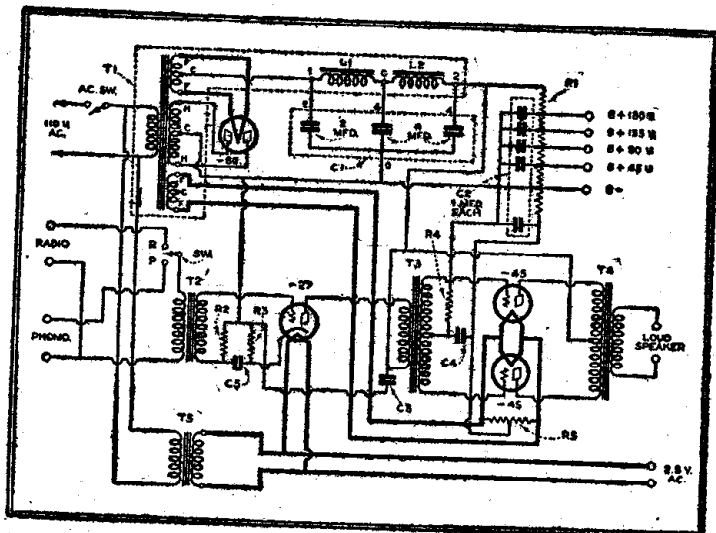

Circuit No. 32

ventional 30 henry type with a Mershon electrolytic condenser. Intermediate B potentials are obtained by the use of a voltage divider between the B plus and B minus terminals, each intermediate tap of course being by-passed by a 1 mfd. filter condenser. The push-pull stage makes use of the standard circuit for its grid and plate connections. The filaments of the tubes, however, are heated by an additional low voltage secondary of the power transformer. This secondary is center-tapped so that in conjunction with resistor R2 (its resistance depended on the type of tube used) and the by-pass condenser C7, provide an automatic C bias.

CIRCUIT No. 32 is a schematic diagram of a power amplifier power supply device employing two -45 tubes in a push-pull circuit, as well as a -27 tube as the first audio amplifier and from which the supply for the

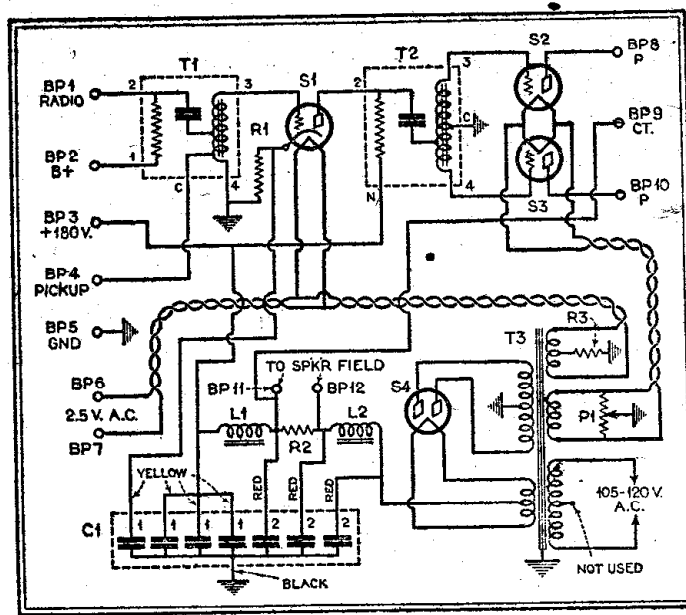

Circuit No. 33

plate voltage for the radio frequency, detector sections of the radio receiver may be obtained. The power supply makes use of a power transformer, T1 supplying approximately 350 volts to the full-wave rectifier tube, -80. The output of the rectifier is filtered by the usual condenser bank and filter chokes. The speaker is pro-

ected from the direct current by the output transformer, T4. R4 is a fixed resistor of 800 ohms shunted by a 1 mfd. condenser of the filter variety and provides the C bias for the grid of the power tubes. The resistor, R1, dropping the high voltage to the intermediate taps, 180 volts, 135 volts, 90 volts and 45 volts, should have a total resistance of 30,000 ohms and capable of passing 125 milliamperes. This wire-wound resistor may for ease of operation have sliding contacts for the above-mentioned intermediate voltages. Each of these intermediate taps, of course,

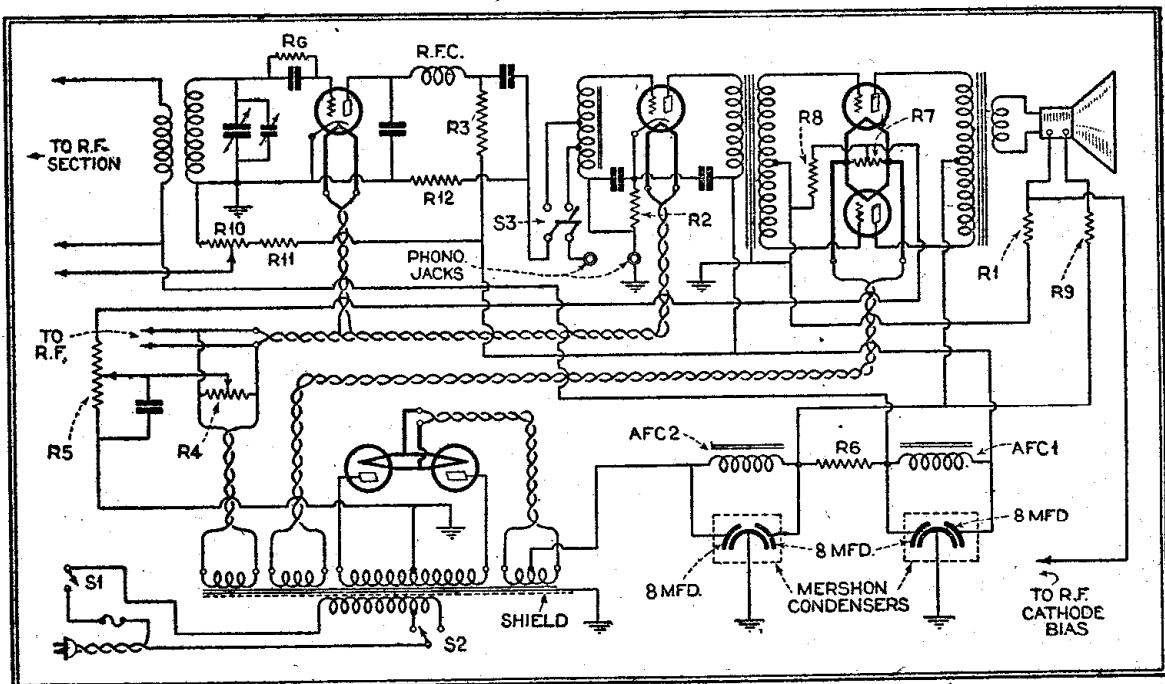

Circuit No. 34

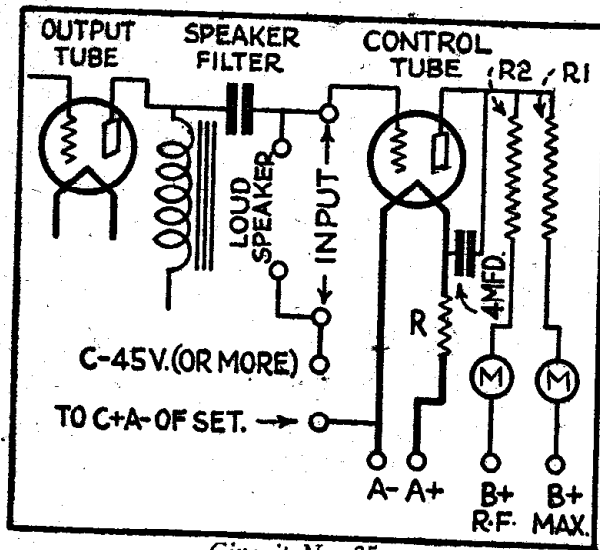

Circuit No. 35

being by-passed by 1 mfd. condensers, C2. Provision has been made in this amplifier for connection to a phonograph pickup for electrically playing phonograph records.

CIRCUIT No. 33 is a schematic diagram of a two step audio frequency amplifier and power supply somewhat similar to that in circuit No. 32. Here, however, the audio transformer is replaced by impedance coupling in both the first and second stages. It should be also noted that provision has been made for the energizing of a dynamic speaker field coil from the filter circuit of the power supply. The resistances, R1 and P1, will of course be depended on the type of tubes used. An amplifier of this type is satisfactory for connection to a radio receiver or the play-

ing of phonograph records through the medium of a phonograph pickup.

CIRCUIT No. 34 is that of the detector unit of a radio receiver coupled to a straight stage of audio frequency amplification of impedance followed by a one step push-pull transformer coupled amplifier. Provision has been made in this circuit for the A, B and C potentials for a radio frequency tuning section to be incorporated, its energy, of course, being fed into the detector stage. The power supply in this circuit is rectified by two half-wave rectifier tubes -81 and filtered through the medium of the audio frequency chokes, AFC1 and AFC2, as well as two dual-Mershon condensers having a

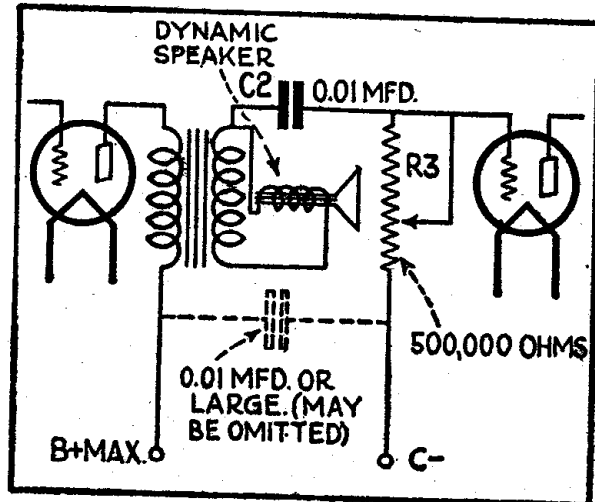

Circuit No. 36

capacity of 8 mfd. Field excitation of the field coil of the dynamic speaker is pro-

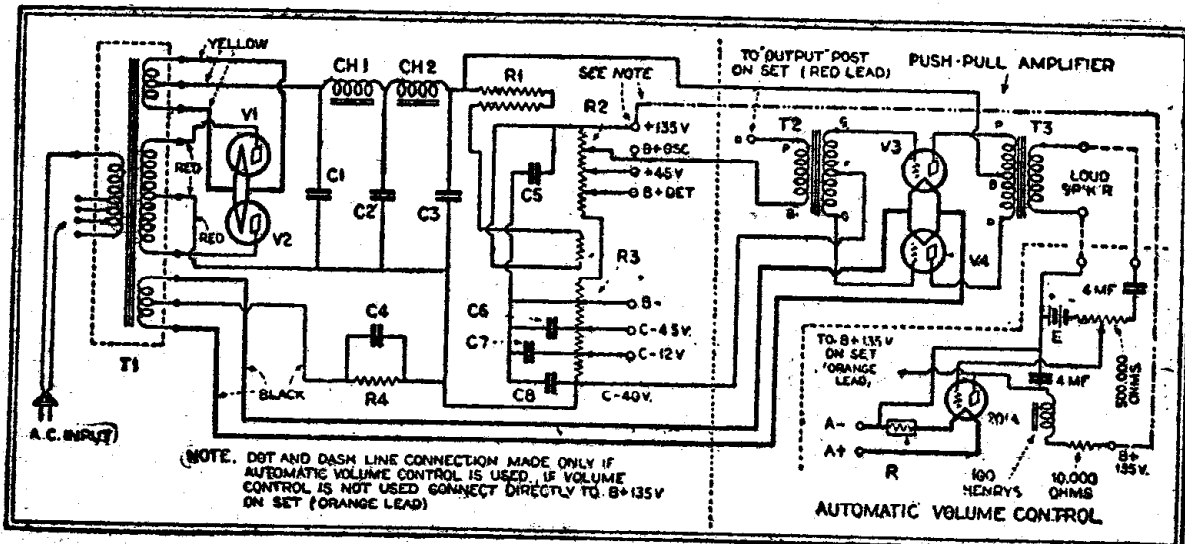

Circuit No. 37

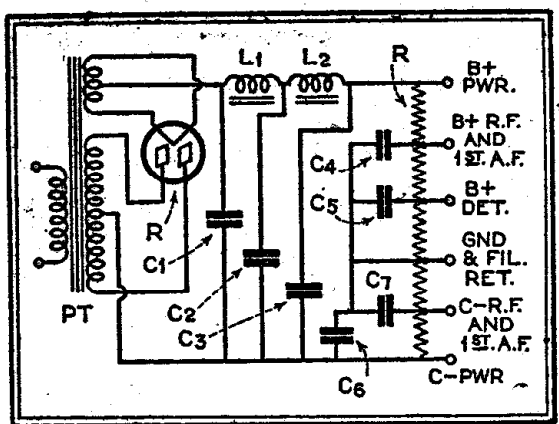

Circuit No. 38

vided for by the B power of the power supply through the resistors R1 and R9. The primary of the power transformer is so designed that line voltage variations may be taken care of by the switch, S2.

circuit No. 17), but also incorporates the automatic volume control which was worked out by the designer, Mr. R. E. Lacault, shortly before his death. The constants for the latter are given as they are of special interest to experimenters. It will be noted here that rectification is by two -81 half-wave rectifiers and the filter consists of the conventional audio choke, CH1 and CH2 and the filter condensers, C1, C2, C3.

CIRCUIT No. 38 is a schematic diagram of one of the simplest of the B battery eliminator circuits. Here the -80 tube full-wave rectifier tube serves as the rectifying unit, being followed by the conventional audio choke coils, L1 and L2, and the filter condensers, C1, C2 and C3, to complete the filtering action required for smooth

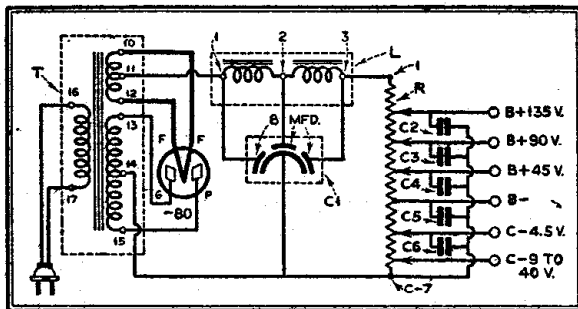

Circuit No. 39

CIRCUIT No. 35 and 36. In these two circuits are shown methods of automatic volume control. Here the control tube is in both cases the -01A type. After the desired volume is controlled manually, the volume control tube will automatically hold the signal to this level over wide variations of swinging and fading. The resistors, R, in these two circuits will of course be depended on the type of radio receiver in which they are to operate.

CIRCUIT No. 37 is interesting not only because it gives a complete schematic circuit of the power supply and amplifier for the RE-29, (See

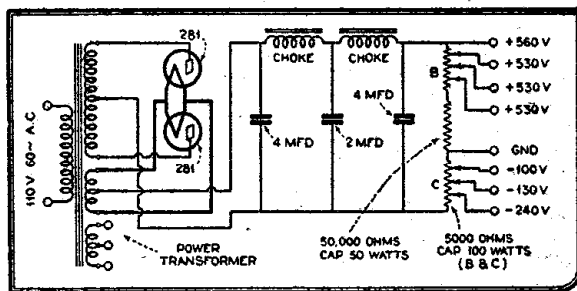

Circuit No. 40

d.c. plate potentials. A voltage divider resistance, R, (sometimes known as a bleeder) is directly connected across the negative and positive terminals of the rectifier and filter system. In this particular circuit provision has been made for obtaining two sets of grid biases, commonly known as C minus potentials, as well as intermediate B battery voltages for correct operation of the radio frequency, detector and audio

portions of the radio receiver. Each of these intermediate taps is by-passed by at least a 1 mfd. filter condenser, having a safety factor well in excess of the voltage applied across it.

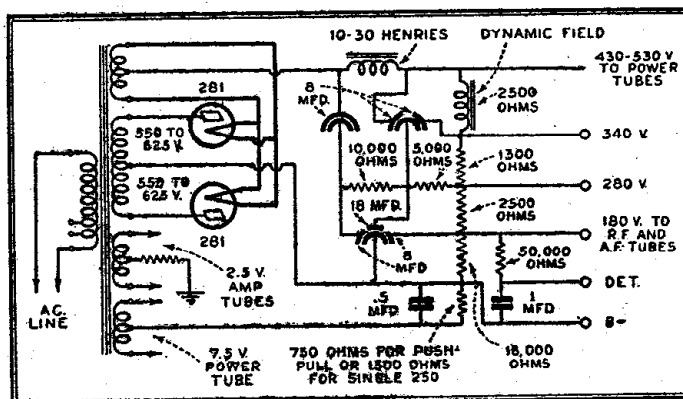

Circuit No. 41

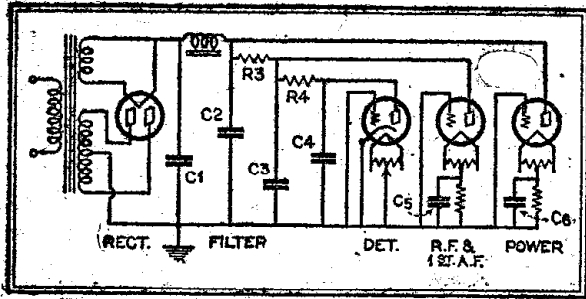

Circuit No. 42

CIRCUIT No. 39 is a schematic diagram of a B power unit similar to that shown in circuit No. 38 except that here the compact electrolytic condenser has replaced the filter condensers across the audio choke coils. The power transformer, T, consists of a primary whose terminals 16 and 17, connect directly to the house lighting circuit. A low voltage secondary provides the 5 volts necessary for the heating of the filament of the -80 full-wave rectifying tube, while a high voltage secondary whose terminals 13 and 15 are directly connected to the two plates of the rectifier tube and the center tap 14, is the minus terminal of the entire system.

CIRCUIT No. 40 is that of a high voltage B power supply where the secondary having 750 volts per section, is fed to the plates of a pair of -81 tubes, followed by the conventional choke coils and filtered with the aid of a 4 mfd. and 2 mfd. and a

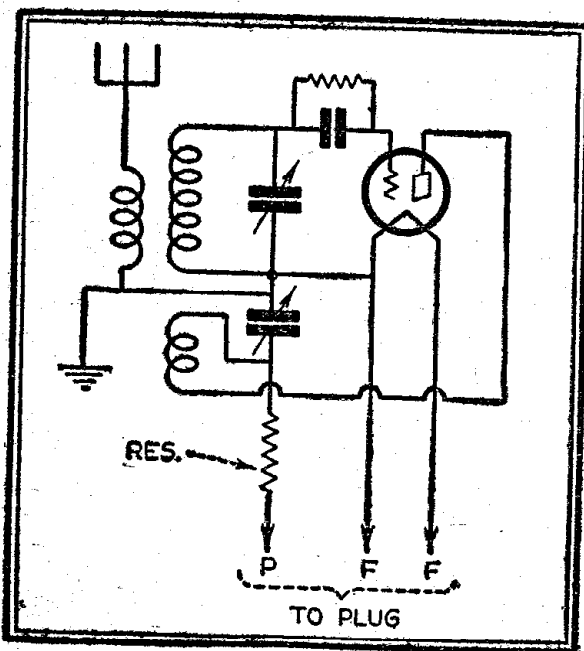

Circuit No. 43

4 mfd. filter condenser. Provision has also been made in this power supply for obtaining high voltage grid biases. A power supply of this type is ideally suited for a high quality high power resistance coupling audio amplifier, such as illustrated in circuit diagram 29.

CIRCUIT No. 41 is also a schematic diagram of a power supply using the -81 tubes in full-wave rectification, but unlike the circuit shown in No. 40, the filter condensers here are the high capacity electrolytic type. It will also be noted in this circuit diagram that allowance has been made for the energizing of the dynamic speaker field coil as well as an automatic

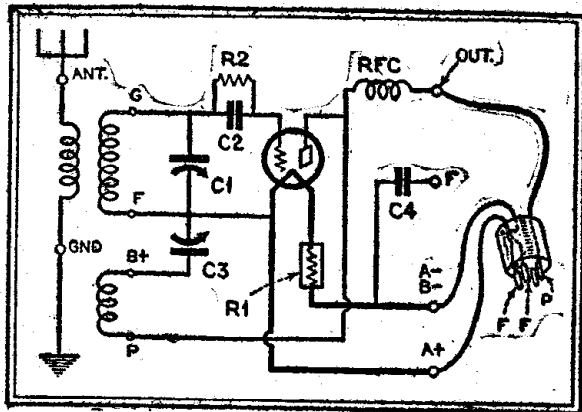

Circuit No. 44

C bias for either a single or push-pull -50 tubes in the output audio stage. An additional secondary of low voltage is part of the assembly of the power transformer and may be used for both a.c. screen-grid tubes and -27 tubes in the radio frequency amplifier, detector and audio stages of the radio receiver.

CIRCUIT No. 42 is a schematic diagram of how the B potentials and C battery biases are obtained from a B supply unit. The resistances R3 and R4, reduce the high B potential proportionately for operation on the plates of the tubes in the various sections of the radio receiver. The tube represented here as the detector tube, is provided with a center-tapped resistor across its filament terminals, the center-tap and the cathode being connected to B-minus and ground, while the first and second audio tubes, both having center-tapped resistors across their filament terminals, require the proper value resistance

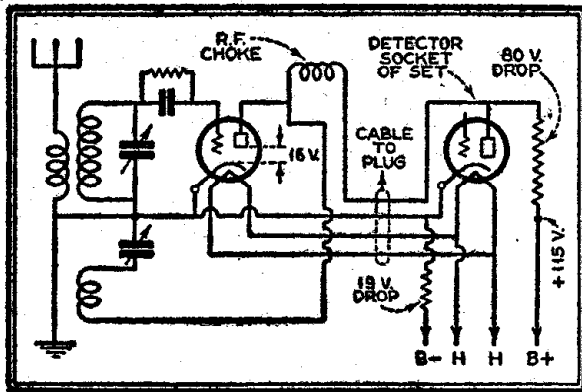

Circuit No. 45

in series with the center tap at ground. In all cases, these resistors should be shunted by by-pass condensers, as shown by the symbol C5 and C6.

CIRCUIT No. 43 is a schematic diagram of a short-wave adapter unit for use with the battery-operated radio receiver of the broadcast variety. Usually the diameter of the inductance coils for such a unit are smaller in diameter than those of the broadcast receiver and have many less turns as well as a smaller capacity variable condenser for the tuning. The grid leak and condenser in this circuit are of the conventional values while the resistance, RES, in series with the plate lead must necessarily be found by experiment.

CIRCUIT No. 44 is also a circuit diagram of a short wave adapter for battery-operated receivers. Here, however, a radio frequency choke coil has been included in the plate circuit and the actual connections to an adapter plug are shown. Usually, in short wave adapters, plug-in coils are used permitting the tuning over the entire short-wave spectrum.

CIRCUIT No. 45 is the schematic diagram of a short-wave adapter for use on an a.c. operated receiver. Here the tuning unit is very similar to that shown in circuit No. 43 with the exception that the

tube is of the indirect heater type -27. Particular attention is called to the fact that such a circuit as this will not provide satisfactory operation when the detector tube of an a.c. operated broadcast receiver is followed by a stage of resistance coupling. Here although a high voltage of 115 volts is supplied to the lower side of the plate resistor, it will be found that approximately a drop of 80 volts takes place in this resistor, and with an extra drop of approximately 19 volts between the cathode and B minus through the biasing resistor, the voltage between the plate of the detector and the cathode of the same tube in the neighborhood of 16 volts is not sufficient for correct operation. It necessarily follows therefore that for satisfactory operation,

the first stage of audio frequency amplification must be transformer coupled.

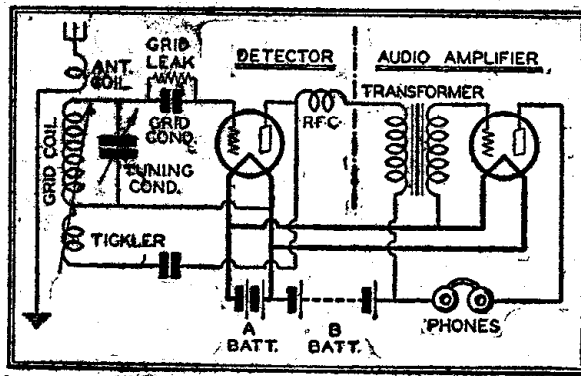

Circuit No. 46

CIRCUIT No. 46 is a schematic diagram of one of the simplest yet most efficient short-wave receivers consisting of regenerative de-

detector and one stage transformer-coupled audio amplifier. The inductance coils in this circuit are of the plug-in variety, permitting quick and easy shifting from one

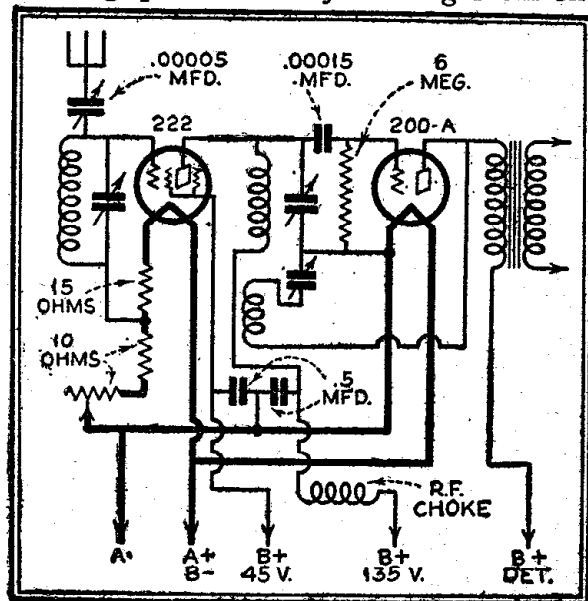

Circuit No. 47

wave-band to another. A radio frequency choke coil is connected in series with the plate of the detector tube and audio frequency transformer preventing radio frequency currents in the audio frequency circuit. A blocking condenser in series with the detector plate and tickler coil eliminates the shorting of the B battery

through the transformer, radio frequency choke coil, tickler and back to filament. With radio receivers employing a circuit similar to this, approximately 20,000 American and foreign amateurs have been able to hear signals half-way around the world. To this circuit, of course, may be added an additional stage of transformer-coupled audio frequency amplification.

CIRCUIT No. 47 is that of a short-wave receiver making use of the battery-operated screen-grid tube as a tuned radio frequency amplifier, and a -00A super-sensitive tube as the detector. Due to the extremely high amplification constant of the screen-grid tube, a high

minus filament of the same tube. Stabilization of the r.f. stage is obtained by the use of the radio frequency choke and two .5 mfd. condensers. The correct automatic C bias for the screen-grid tube is obtained by tapping a 25 ohm resistor, 10 ohms (up) from the filament control rheostat. Regeneration on the detector tube is controlled by a variable condenser. A circuit of this type entirely removes the tendency of a large broadcast antenna effecting the regenerative qualities of the detector tube, eliminating dead spots as well as preventing re-radiation into the antenna system.

CIRCUIT No. 48 is a schematic diagram

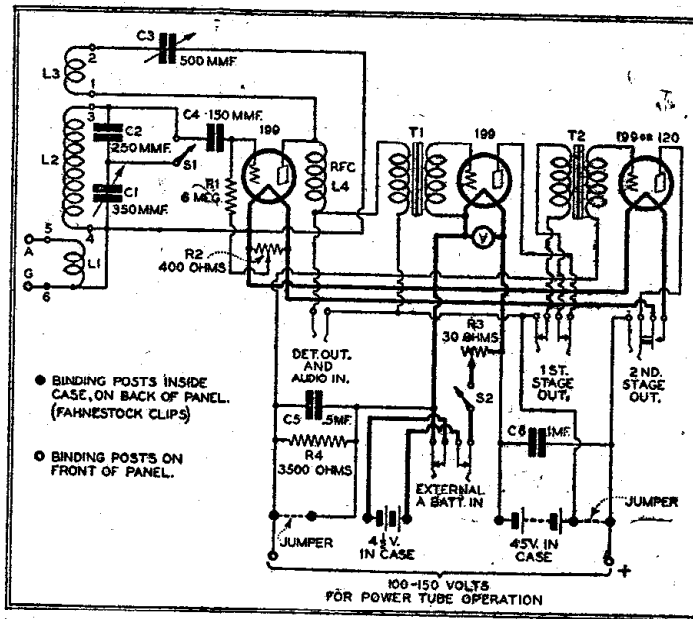

Circuit No. 48

gain is obtained with a circuit of this type. It will be noted that one inductance serves as the plate coil as well as the grid coil for the -22 and -00A tubes. Isolation of the plate potential on the -22 tubes is provided by the .00015 mfd. grid condenser, and the shunting of the grid leak between the grid of the detector tube and

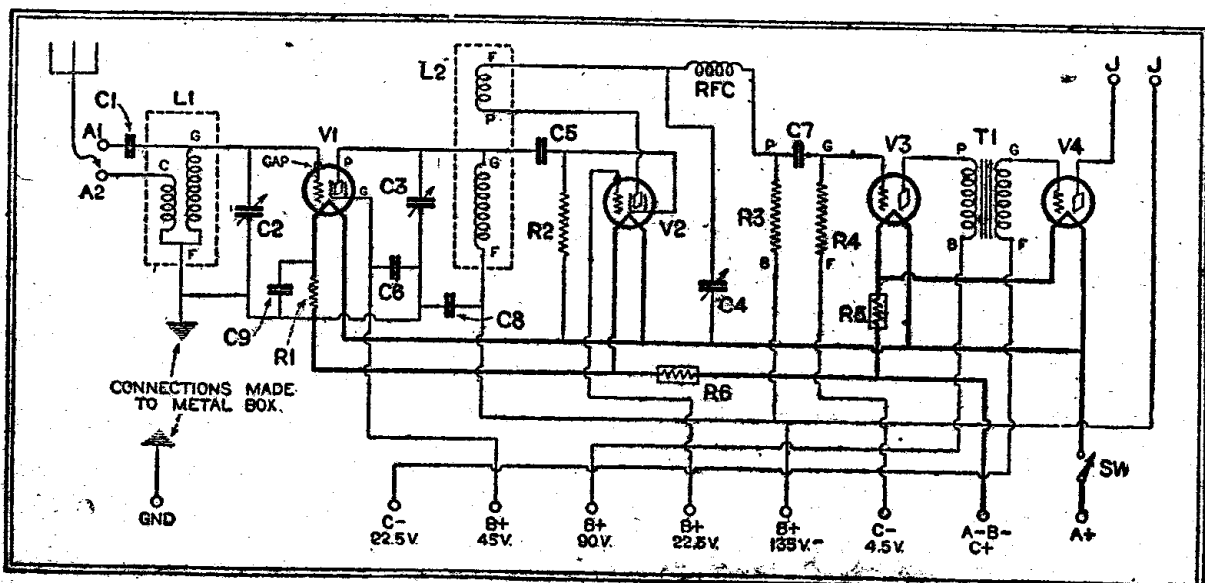

Circuit No. 49

of a short-wave receiver for the covering of short-wave bands as well as broadcast bands, by means of placing the fixed condenser C2 (250 mmfd.) in series or shorted circuit. A circuit of this type employing the small dry cell -99 tube can readily be constructed as a portable unit using extremely small B batteries for the B supply and 4½ volts C batteries as the A supply. When operated in conjunction with the short-wave transmitter shown in circuit No. 55, it is a truly portable short-wave station.

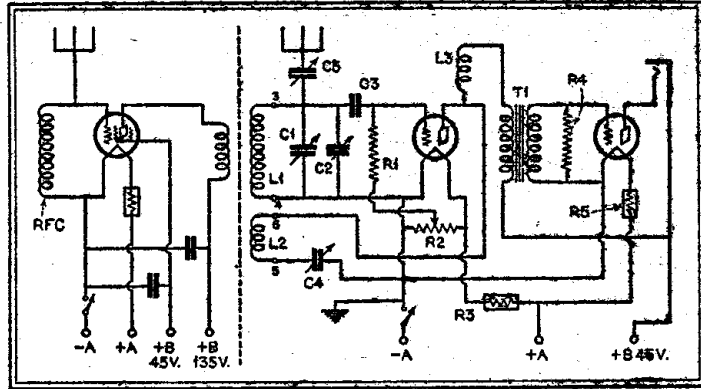

Circuit No. 50

tions. A vast improvement has been noted in following such a detector by a resistance-coupling stage of audio frequency amplification, which may, of course, then be followed by a transformer coupled amplifier. Such a circuit as this, may easily be operated from dry A batteries, thus permitting its use as a portable unit.

Circuit No. 50 is a schematic diagram of the well known Cornet short-wave receiver which is well known among the radio amateurs fraternity as a real distance-getter and stable unit. The original receiver consisted of a regenerative detector and one stage of audio amplification transformer-

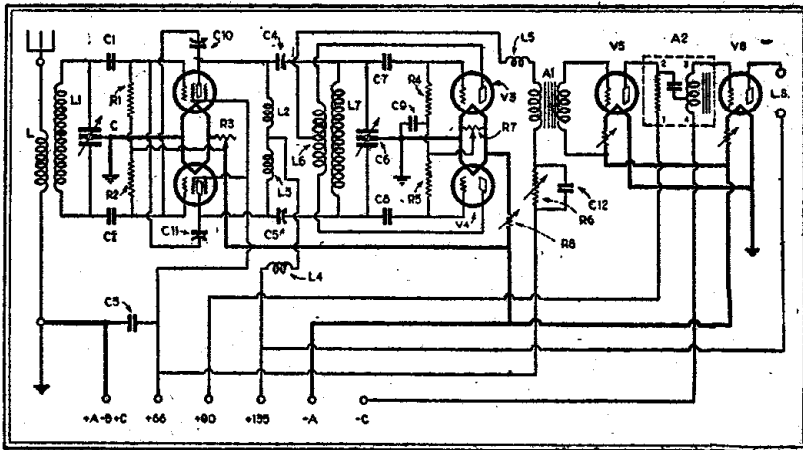

Circuit No. 51

Circuit No. 49 is a schematic diagram of one of the most efficient tuned radio frequency short-wave receivers ever developed. In this circuit the battery-operated screen-grid tubes are used in two distinct and separate methods. First, as a radio frequency tuned stage and second as a space charge regenerative detector. The radio frequency stage in this circuit is very similar in design to that shown in circuit No. 47. In the detector circuit, however, the screen-grid of the screen-grid tube serves as the tuning grid, and the tuning or control grid is connected directly to plus B 22½ volts, the plate, of course, having its conventional connec-

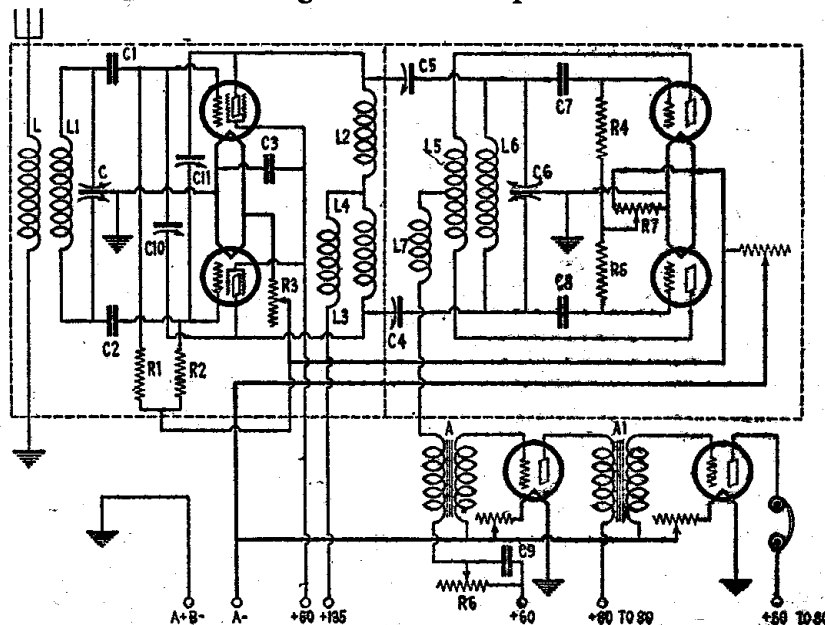

Circuit No. 52

coupled. To this, however, may be added an untuned radio frequency stage employing the screen-grid -22 tube coupled to the antenna circuit by a radio frequency choke coil. Extremely fine tuning is accomplished with this circuit by the use of a .000005 mfd. condenser, C2, shunted across the .00015 mfd. variable condenser, C1. Regeneration is effected by the condenser C4, having a capacity of .00025 mfd. The resistance, R2, is a 200 ohm potentiometer permitting the swinging of the detector grid bias from positive to negative filament. L3 is a conventional 85 millihenry radio frequency choke, while the resistance R4 is a 500,000 ohm grid leak type of resistor, eliminating tube noises.

CIRCUIT No. 51 is a schematic diagram of a short-wave receiver employing push-pull radio frequency amplification as well as a stage of push-pull detector followed by a stage of transformer-coupled amplification and a stage of impedance audio amplification. One of the main advantages of the circuit of this type is the extremely stable operation in the short-wave band around 5 and 7 meters. It, of course,

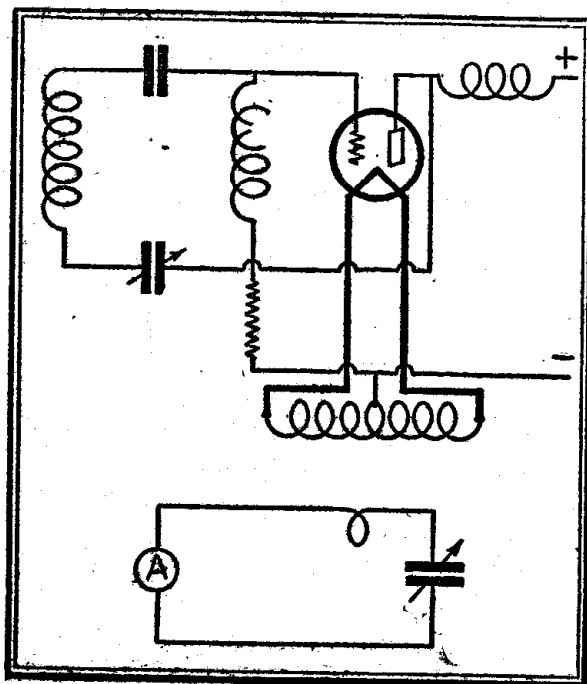

Circuit No. 54

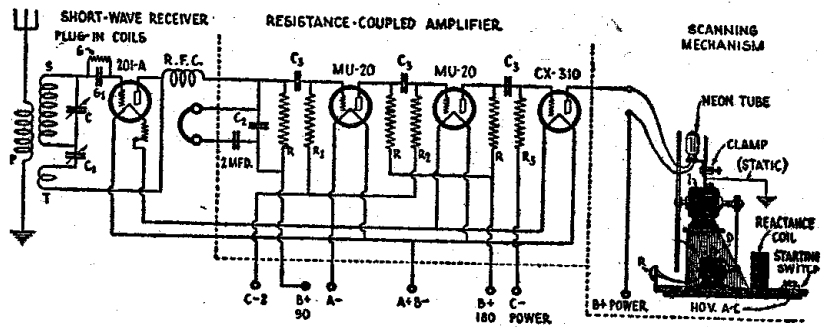

Circuit No. 53

goes without saying that the condenser C and C6 should be as nearly a match as possible as well as the resistance, R1, R2, R4 and R5. Choke coils of 85 millihenries are employed at L2, L3, L4 and L5. A receiver of this type, although especially designed for the extremely low wave band, will provide its user with satisfactory operation in the short-wave broadcast band as well as the amateur bands.

CIRCUIT No. 52 is also of a push-pull radio frequency stage and push-pull detector similar to circuit No. 51. In this circuit, however, the second audio amplifier stage has been replaced by a transformer. One noteworthy feature of this circuit is its operation on plate potentials up to and including 135 volts. Regeneration is controlled by the variable resistance R6 shunted by the by-pass condenser C9. Although rheostats are shown controlling the filament voltage in each section of the set, these may be replaced by the use of automatic filament ballasts.

CIRCUIT No. 53 is a schematic diagram of the conventional short-wave receiver employing plug-in coils and a tickler for regeneration, followed by a resistance-coupled audio amplifier making use of the high-mu tubes in the first two stages and a -10 power tube in the output stage. Such a short-wave receiver and audio amplifier is intended to operate a television unit consisting of a scanning disc and its associated driving unit with a neon lamp as the light source. A resistance-coupled audio amplifier is ideally suited for television signals, due of course, to its extremely flat frequency curve. For satisfactory television signals, it will be necessary for the operator to know the disc speed at the transmitter as well as the number of holes on the disc.

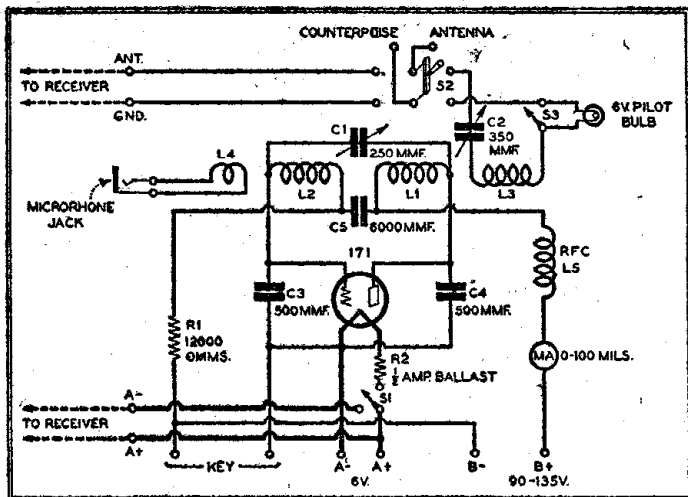

Circuit No. 55

to be transmitted and are tuned to resonance by the condenser C1, having a capacity of .00025 mfd. L3 comprises the primary coil for the antenna and counterpoise systems. The antenna is tuned to resonance by a .00035 mfd. condenser, C2. This transmitter is intended for operation either as a code transmitter or for phone work. Loop modulation is made use of when phone work while the B negative supply is broken when used with a key. The circuit is intended for use as a companion unit to the short-wave receiver, circuit No. 48, and is ideally suited for motor car, motor boat or aeroplane use.

CIRCUIT No. 54 is a conventional circuit used for a short-wave transmitter. This circuit is the simplest of the transmitting circuits and is shown without its accessory units such as the plate supply unit, key or antenna circuit. The fixed condenser is used as a blocking condenser and should be of sufficiently high flash test to eliminate the danger of breakdown as should also be the variable condenser. Two radio frequency choke coils are necessary, one in the B plus lead to the plate of the tube, the other in series with the grid and the resistor which is also connected to the center-tap of the filament transformer and B minus. Included in this circuit diagram is that of a simple wavemeter having inductance coil and a variable condenser to tune the wavelength of the transmitter.

CIRCUIT No. 55 is a schematic diagram of a short-wave transmitter making use of the -71 tube as an oscillator. The plate and grid coils, L1 and L2 respectively, are sized according to the wavelength

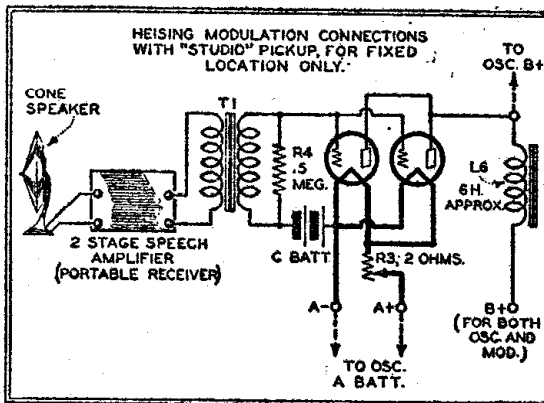

Circuit No. 56

CIRCUIT No. 56 is a schematic diagram of a home constructed Heising modulation system for use on the short-wave transmitter for phone work. Here the cone speaker is used as a microphone, the energy being stepped up by a two-stage speech amplifier followed by coupling transformer, T1, and a pair of tubes, their grids

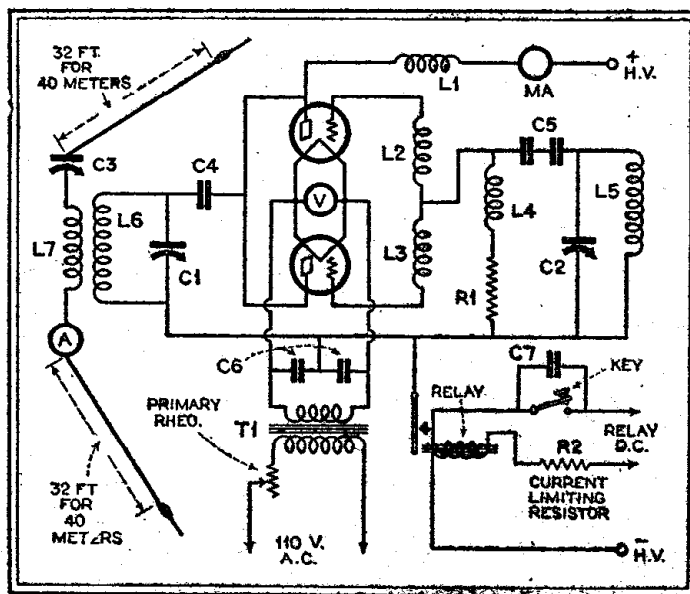

Circuit No. 57

and plates being parallel respectively. An audio frequency choke, approximately 6 henries, is inserted in the B supply to the plates of the modulator tubes as well as the oscillator tube in the transmitter. Such a modulation system is suited for studio work more than portable work, due of course to the additional weight of the improvised microphone and the amplifier modulator equipment. It is well worth noting that a resistance, R4, of .5 megohms is shunted across the secondary of the coupling transformer, T1, flattening out the frequency response curve as well as reducing tube noises from the two stage speech amplifier.

trolled by making use of the relay in the minus B lead as shown. A circuit of this type is known as the tuned plate tuned grid.

CIRCUIT No. 58 is that of a high power high quality crystal control short-wave transmitter. In this circuit, the crystal ground to a predetermined frequency of 85 meters is shown in the upper left. The crystal is used to stabilize the oscillator tube (-10) keeping it on its frequency. The energy from the oscillator tube is fed to a second -10 tube, known as a frequency doubler which reduces the wavelength to 42.5 meters. The energy from this tube

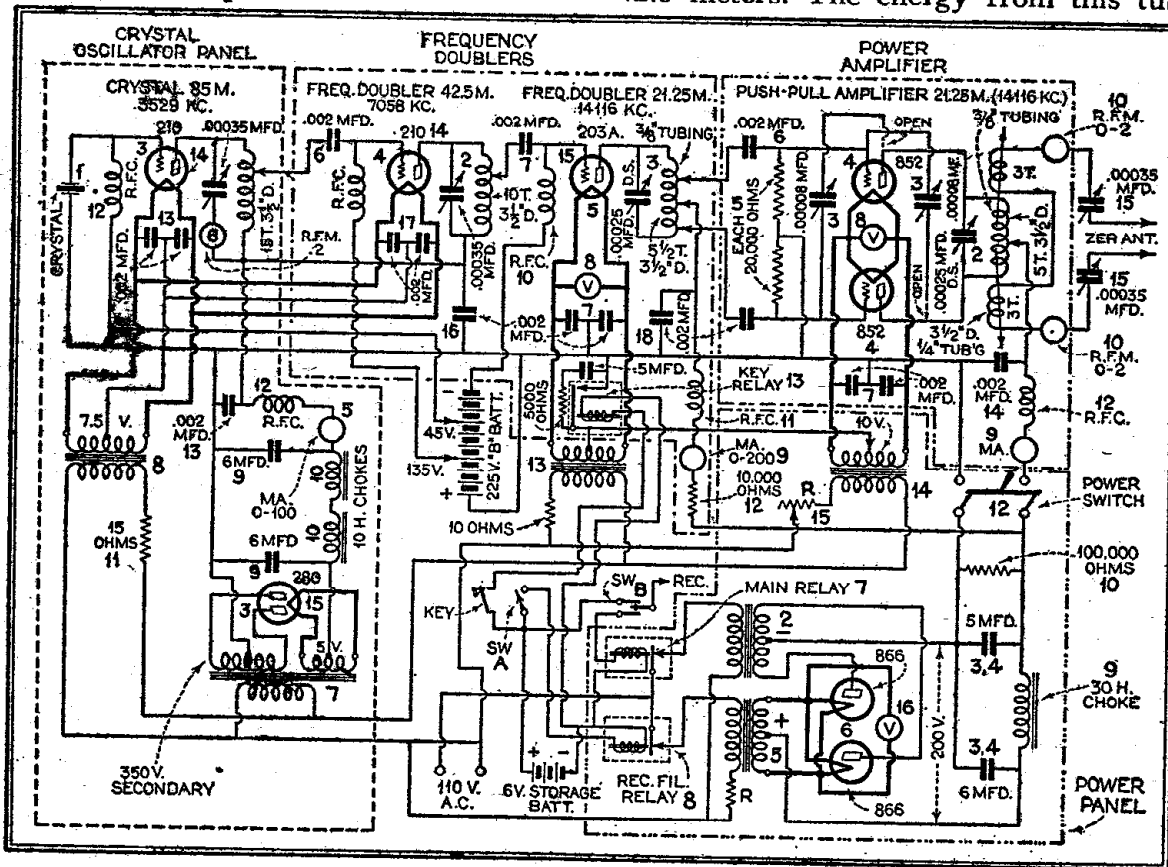

Circuit No. 58

CIRCUIT No. 57 is a schematic diagram of a short-wave transmitter for use on 40 meters employing two oscillator tubes in a parallel circuit. For this wave-length both the counterpoise and antenna should be approximately 32 feet in length the antenna being tuned to resonance by the variable condenser C3. The generous use of radio frequency choke coils, L1, L2, L3, L4, stabilize the transmitter eliminating almost entirely the tendency to swing from its wavelength. The circuit of this type may very easily be remotely con-

being fed to a 50 watt tube -03A which is also a frequency doubler meaning the signal is now at 21.25 meters, which is impressed on the grids of a push-pull amplifier employing 75 watt tubes (852). The inductance in the plate circuit of the power amplifier, is inductively connected to a pair of inductances which feed directly to a zeppelin antenna, both sides of the antenna being tuned with .00035 mfd. condensers. A transmitter of this type is primarily intended for code work but may easily be used for phone work

by including a modulation system. In the circuit diagram No. 58 is also shown the power supply for this high power transmitter, along with the constants of each of the components which go to make up the completed unit.

Circuit No. 59 and 60 are the circuit diagrams and charts for a vacuum tube voltmeter. A unit of this type is of special interest and value to the advanced serviceman and laboratory. With the vacuum tube

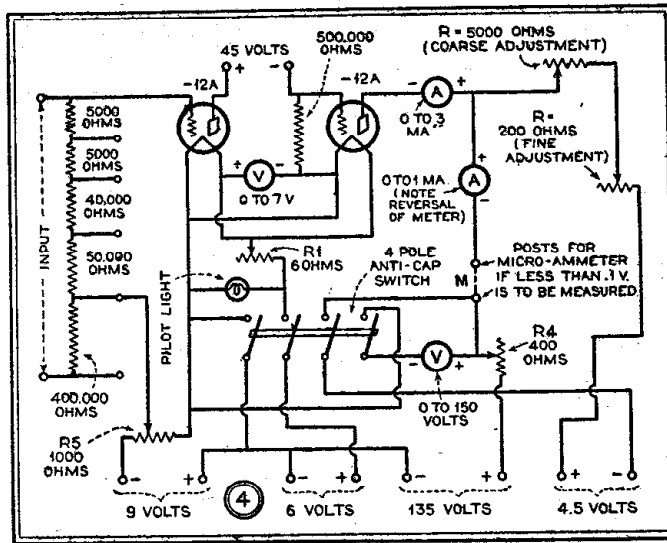

Circuit No. 59

this circuit, audio frequencies over wide ranges can be obtained for use in testing audio transformers, loud speakers, etc. A unit of this type may be constructed as a portable unit, thus doubling its uses to the serviceman and the serious-minded experimenter. The oscillator

circuit employs four tubes. Complete details of the parts are given as follows: The resistance R1 is a 1.5 ohm rheostat while the grid leak R2 is 5 megohms; R3 2 megohms and R4,

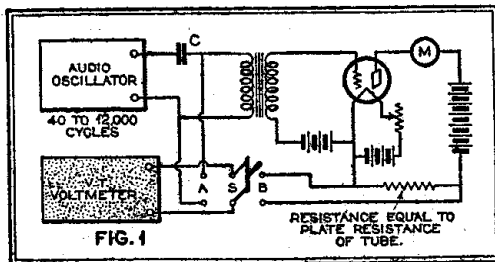

FIG. 1

FREQUENCY	INPUT VOLTS	OUTPUT VOLTS
25	2.0	40.5
50	2.0	53.1
65	2.0	56.2
100	2.0	59.1
150	2.0	61.7
300	2.0	62.9
ETC.	ETC.	ETC.

FIG. 2

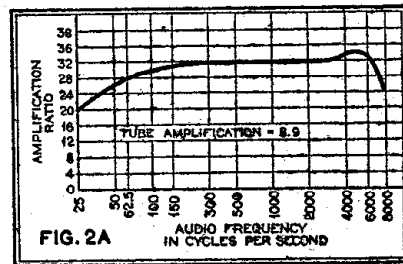
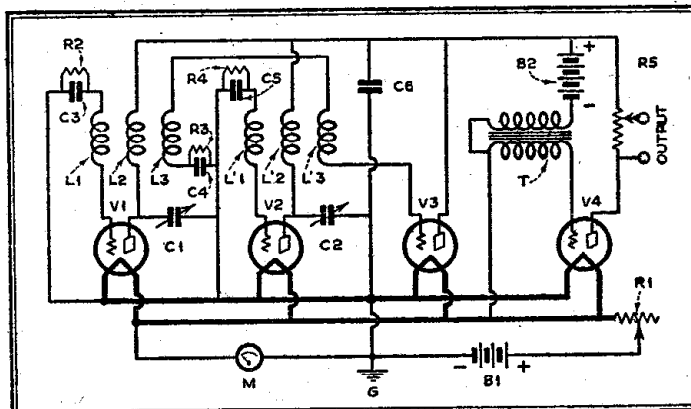

FIG. 2A

Circuit No. 60

meter it is possible for the user to read directly the overall gain of a radio receiver on any wavelength, as well as the tube amplification constant along with its associated audio amplifier over the audio frequency band. It is with vacuum tube voltmeters of a similar design as shown in circuit diagram No. 59, that the radio engineer finally passes and approves of a radio circuit.

Circuit No. 61 is a schematic diagram of an audio frequency oscillator. By means of the inductances and tuning condensers C1 and C2 in



Circuit No. 61

250,000 ohms. The potentiometer, R5, has a total of 12,000 ohms; M, a d.c. voltmeter has a maximum scale reading of 8 volts; the battery, B1, for lighting the filaments of four tubes is 6 volts, while the B battery, B2, is 135 volts. Iron core inductance, T, is an audio transformer or double impedance coupler, while the air-core inductances L1, L1, 500 turn honeycomb coils; L2, L2, 1500 turn honeycomb coils; L3, L3, 200 turn honeycomb coils; and C1, C2, three-plate variable condensers, C3, C4, C5 are .00025 mfd. and a by-pass condenser

of 1 mfd. for C6. Four tubes of the -01A type are used in positions V1, V2, V3 and V4.

CIRCUIT No. 62 is a schematic diagram of a universal test unit which may be used as a frequency meter using the dip method by

a combination of a coil and condenser. A vacuum tube voltmeter by the placing of an audio transformer across the input terminals and a multi-range volt

and milliammeter in combination with the resistance R5, R6, R7, R8, R9 and R10 as well as employing shunts across the terminals 1 and 2.

CIRCUIT No. 63 is that of a tube tester eliminating the need of batteries by the use of a multi-tapped transformer. In the circuit diagram No. 63 the terminals on the tube sockets are connected in parallel and, by means of a tapped switch, voltage of 1½, 2½, 3½ and 7½ may be obtained. The milliammeter, A, has a full scale deflection of 10 mils and is shunted by the resistance, R1, of 900 ohms tripling the scale reading.

R2, a 50 ohm center-tapped resistor, is connected across the filaments, the center-tap going to two resistors, one being 500 ohms, R3, and the other a 35 ohm, R4. These resistors provide an automatic C bias. Shorting the resistor, R4, by means of the switch SW2 changes the C bias from 4 volts to 1½ volts. Screen-grid adapters can be made up easily by us-

ing old -27 and -01A tube bases.

CIRCUIT No. 64 is a schematic diagram of a radio set and tube tester, small enough to be placed in a portable typewriter carrying case. By means of the plug and cable, tubes may be tested while the radio

receiver is in operation. The rotary switches in both the a.c. volt meter and d.c. milliammeter provides readings of from 1½ mils. to 1500 mils. as well

as 4 to 100 volts d.c. and the standard ranges of power supply potentials now being used on B eliminators and radio receivers. Provision has been made for testing both UX and the UY type of tubes.

CIRCUIT No. 65 is that of a test panel for the radio serviceman's shop or radio laboratory where a unit of high precision readings is required. The power supply for this tester is incorporated in the circuit, eliminating the necessity of an external low voltage transformer or storage A battery. By means of pin jacks and switches, voltages from 0 to 1000 volts may be read on a 1000 ohm per volt

meter, as also may the plate readings up to and including 100 milliamperes. A test may also be made with this unit on the new a.c. screen-grid tube as well as the older models of tubes.

CIRCUIT No. 66 is a schematic diagram of the new Loftin-White direct coupling amplifying system. Economy is the outstanding feature of the Loftin-White

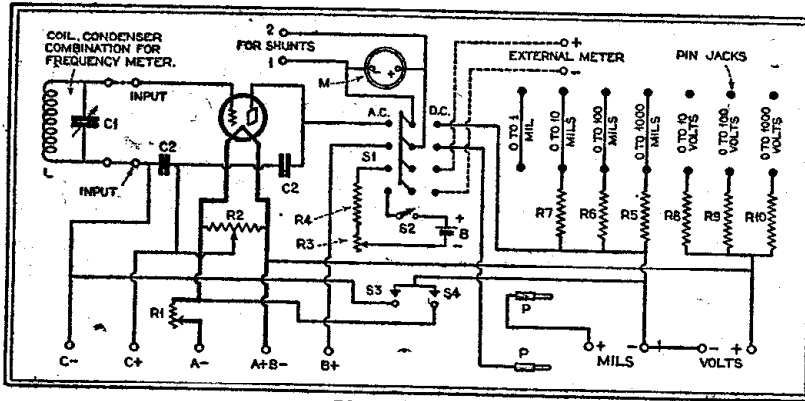

Circuit No. 62

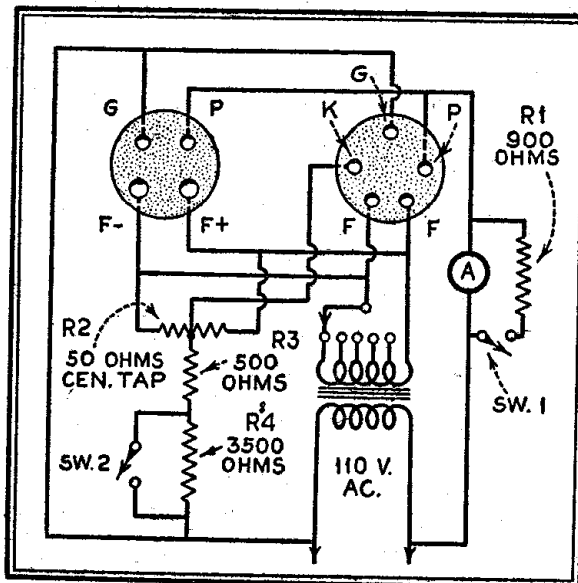

Circuit No. 63

system as exemplified in circuit diagram No. 66. The constants for the amplifier are as follows: R1a, 425 ohms; P, 200 ohms; R1c, 775 ohms; R1d, 4700 ohms; R_c, 500,000 ohms; R3, 50,000 ohms; R5, 25,000 ohms; R6, 100,000 ohms; C_f, C2, C3, 1 mfd.; L, 20 henries; PU, phonograph pickup and VC the pickup's volume control. The input of VT1 is shown to include a phonograph pickup PU, connected

ohms; R_c, 250,000 ohms; P, 400 ohms; C_{hb}, .1 mfd.; C1 and C2, 1 mfd. In a.c. operation of directly-coupled cascaded tube systems, the characteristics depend upon or are influenced by the following features. First, maintaining the operation of all tubes at the midpoint of their operating or output current curves. Second, feedback phenomena at audio frequencies, hum problem, motorboating, trigger action,

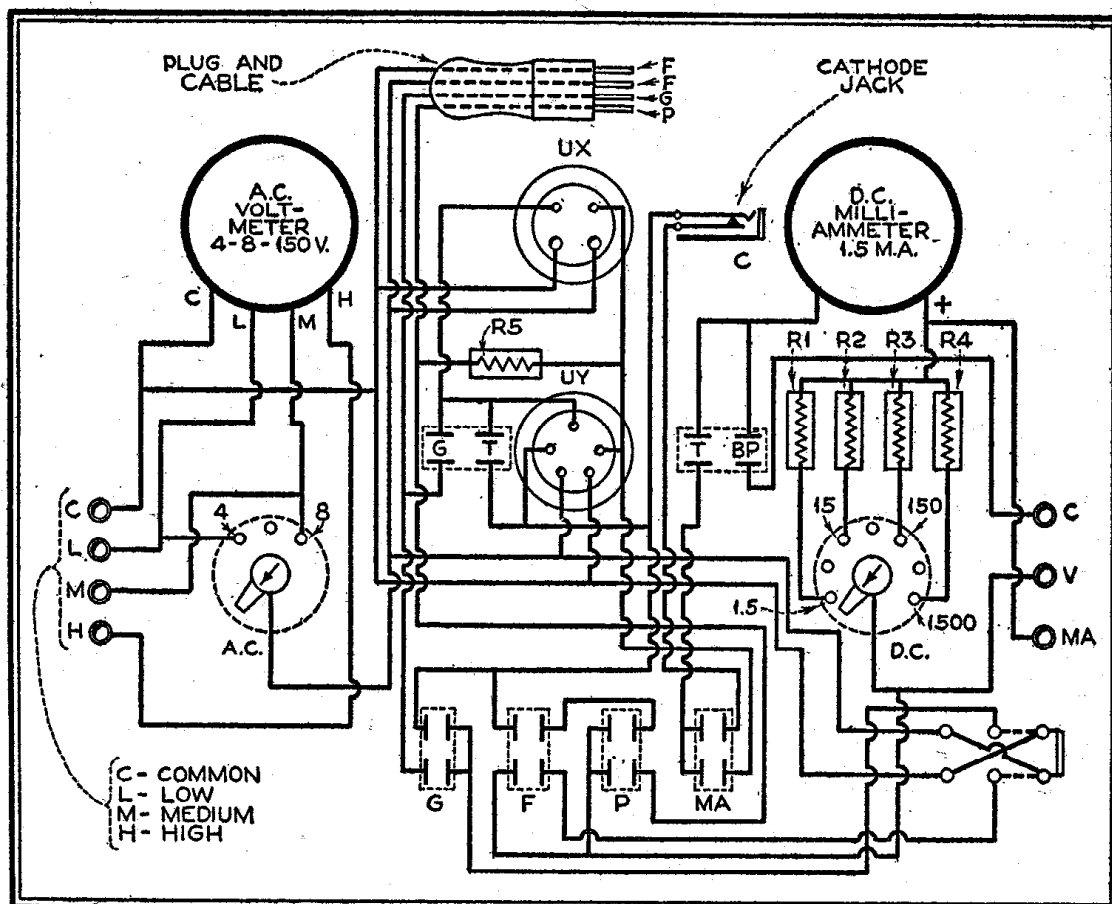

Circuit No. 64

through a conventional resistance volume control VC. Connections should be made directly in the input circuit as shown, a step-up transformer being both unnecessary and undesirable. The pickup may be substituted by a conventional tunable circuit for radio work.

CIRCUIT No. 67 is that of the Loftin-White directly coupled amplifier employing the a.c. screen-grid -24 tube and the super-power tube -50. The constants which follow are slightly different to those given in circuit No. 66. VT1, -24; VT2, -50; R1, 5,000 ohms; R3, 25,000 ohms; R5, 100,000 ohms; R6, 300,000

maximum gain of tube, providing current for auxiliaries such as speaker field, and last, increase to very high gain such as that required for photoelectric cell operation.

CIRCUIT No. 68 is a diagram showing the changes which were made in a standard radio receiver in order to incorporate the Loftin-White direct-coupled amplifier system. In referring to the circuit diagram No. 68, it will be noticed there is nothing unusual in the details of the three stages of tuned single dial control screen-grid radio-frequency amplification. The shaded base W, grounded at G, indicates the metallic chassis to which the various

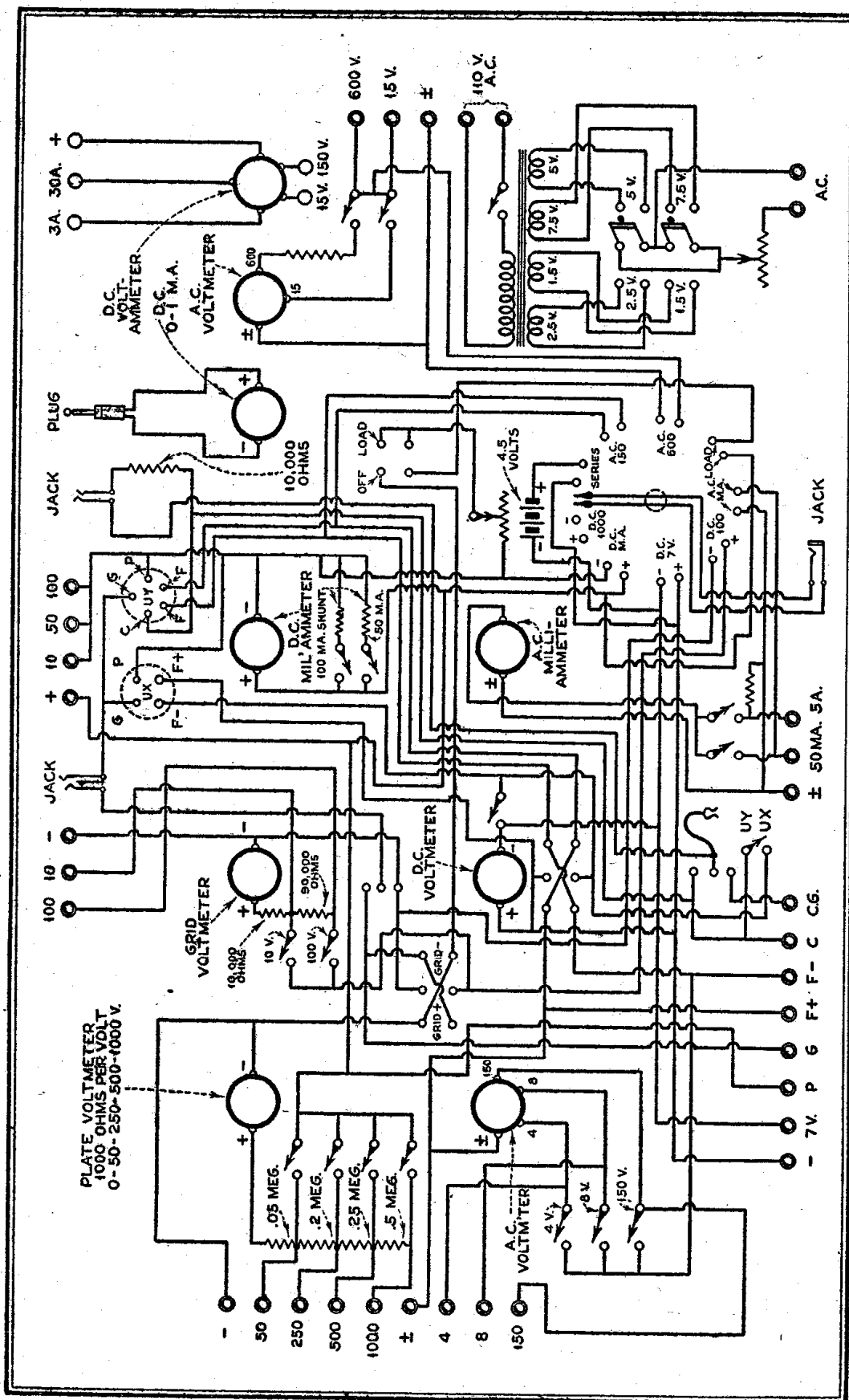

Circuit No. 65

common ground connections are soldered. The antenna terminals, 1 and 2, provide for long and short antenna connections, the terminal 1 being arranged to bring the antenna condenser C_a in series with the antenna as the usual provision for a long antenna. The original commercial set here shown included before conversion a -27 power detector resistance-coupled to a -27 first audio stage in turn coupled to a push-pull -45 output stage, and an elaborate filter and power unit. We used the -27 detector socket for our input tube VT_1 , thus leaving a one -45 output tube to take the place of all that had to do with the resistance coupled first audio stage and transformer coupled two -45 output tubes.

CIRCUIT No. 69 is a schematic diagram of another method of adding one stage

of radio frequency amplification to the Loftin-White direct-coupled amplifier. Any good radio frequency choke L_1 and

a condenser C_4 of .0005 mfd. connected as shown in the output of VT_2 , are additions which are sometimes essential, but under favorable conditions will not be required. Here, V represents one or more tubes of a radio frequency system having one or more tunable circuits TC_1 . The plate circuits of the radio frequency tubes are energized from the filter through a potential reducing resistance, R_7 , of sufficient value to provide the required current for all of the tubes.

CIRCUIT No. 70 is that of the National screen-grid short-wave receiver which embodies two stages of audio frequency amplification. The audio amplifier in this

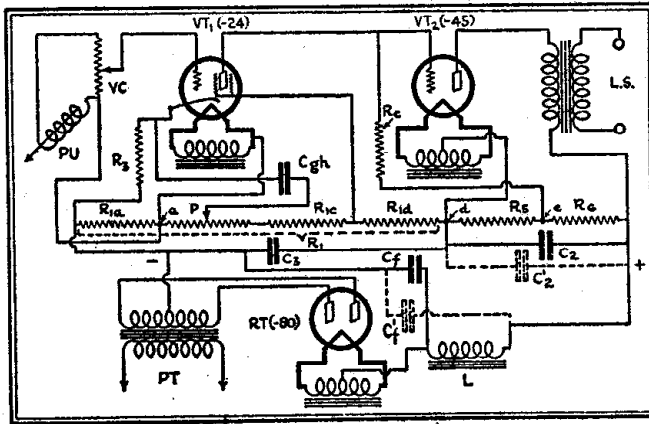

Circuit No. 66

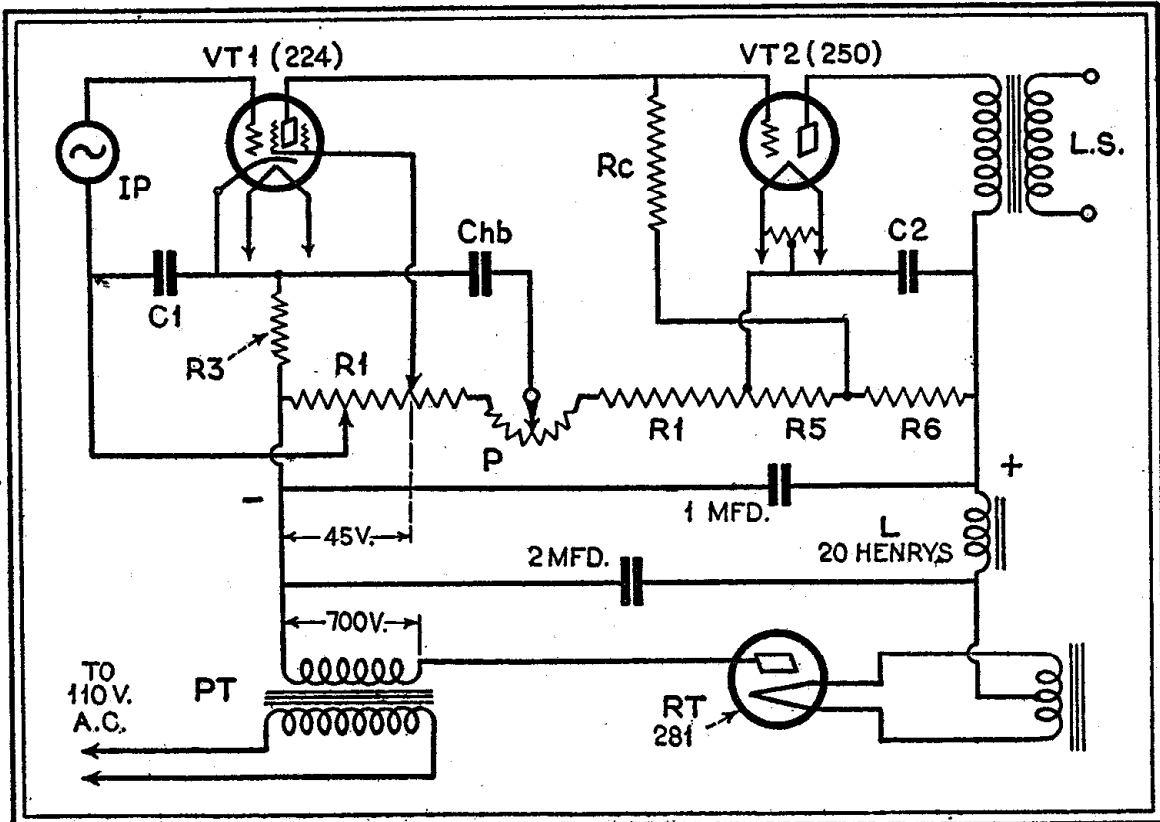

Circuit No. 67

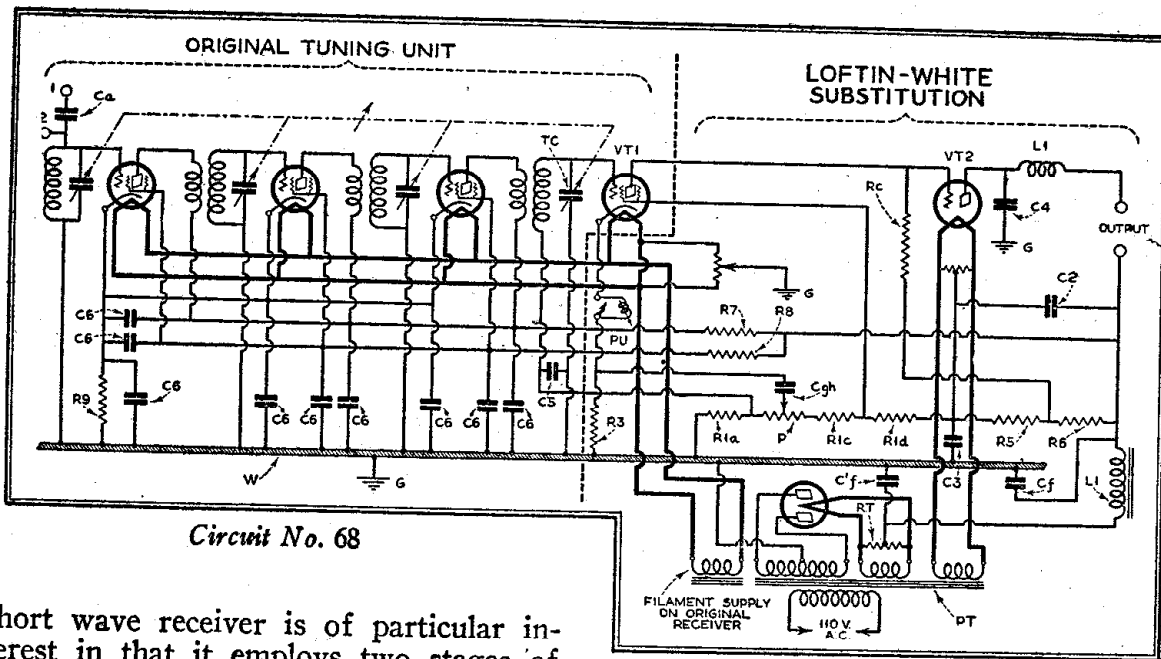

Circuit No. 68

short wave receiver is of particular interest in that it employs two stages of impedance coupling, making use of one high-mu -40 tube and a power output -71A tube. Plug-in coils and a paralleled variable condenser switch enable the operator to tune over a large number of wave bands.

ment of individual tube currents, the push-button switches and the -50 tube bias control are variable. This new S-M 692 amplifier was built with the requirements of uniform transmission over the entire usable audio range interpreting this

CIRCUIT No. 71 is a schematic diagram of a complete Silver Marshall auditorium power amplifier. The special circuit to permit either -50 tube plate current or some of their circuits to be measured is shown at the right hand side. The 2 mfd. 1000 volt condenser which is the first one in the filter system is housed in a separate can so it can be replaced if necessary without disturbing the large condenser bank. A momentary contact switch is closed when the cover and false bottom are in place. Jacks also permit the measure-

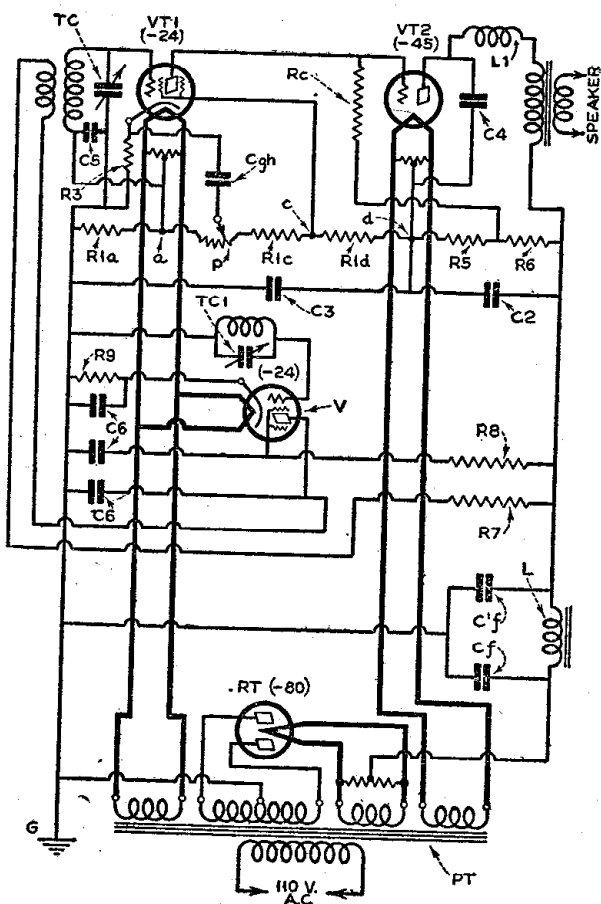

Circuit No. 69

broader frequency range in terms of the requirements of the new speakers and the insistent demand for amplifiers which are capable of reproducing speech faithfully.

CIRCUIT No. 72 is that of the new Lincoln 8-80 super-heterodyne employing 10 tubes in all, the final audio stage employing a pair of -45's. The arrangement of the other tubes are as follows. Oscillator -27, first detector and four intermediate frequency stages -24, second detector and first audio stage -27. One dial control is one of the many features.

CIRCUIT No. 73 is a schematic diagram of the Silver Marshall new band-pass tuner No. 712. The 712 band selector tuner

is designed to use two electrically symmetrical circuits in band-pass or "siamese" antenna coupler arrangement. This circuit was placed ahead of the first radio frequency tube, due first to the fact that any slight misalignment which might arise in unusual cases, due to very large antennas, would least effect the general performance of the receiver. Three -24 screen-grid tubes are used as high gain radio frequency amplifiers and a -27 as a power detector to be followed by a high quality audio amplifying system.

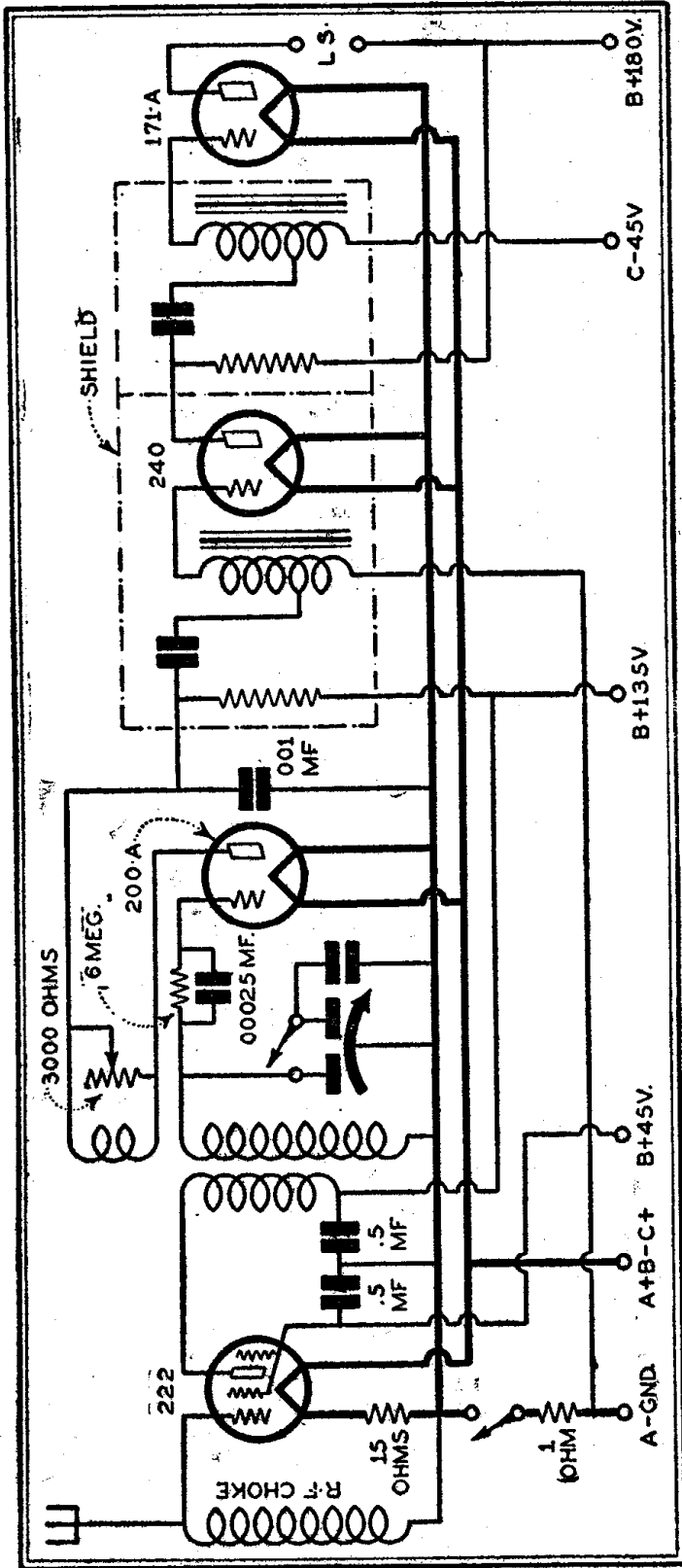

Circuit No. 73

CIRCUIT No. 74 is that of the Atwater Kent screen-grid No. 55. This 7-tube receiver employs two screen-grid tubes as high gain amplifiers in the radio frequency circuit, -27's in the detector and first audio stages, a pair of -45's in a push-pull output audio circuit and a -80 full-wave rectifier for supplying the plate potential to the tubes in the receiver.

CIRCUIT No. 75 is a schematic diagram of the Silver Marshall automobile-radio receiver. Three -24 a.c. screen-grid tubes, a high-mu -40 tube and a -71A tube are those required in this receiver. Circuit connections illustrating the special by-passing and radio frequency choking features are shown in the diagram.

CIRCUIT No. 76 is that of the Pilot 110 volt d.c. line-operated 6-tube radio receiver. The tube performance are as follows; V1, V2, V3 and V4, 112A's; V5, V6 are 171A's. Several noteworthy features have been incorporated in this receiver. First, a complete push-pull filament circuit. Second, a radio-frequency grid-bias connection. Third, an audio channel grid

bias allowance. Fourth, a radio-frequency grid bias tap arrangement and fifth, a plate filter system.

CIRCUIT No. 77 is a schematic diagram of the Silver Marshall a.c. operated short-wave receiver, employing a -24 screen-grid tube as a coupling stage, -27 as detector and first audio and a pair of -45 tubes in push-pull as a second audio stage.

detector. The first audio stage employing a -27 tube is coupled to the detector output through a resistance-coupling unit and a pair of -45 arranged in push-pull fashion complete the audio amplifier.

CIRCUIT No. 79 is a schematic diagram of the Continental Wireless Supply Corp. automobile-radio receiver. The circuit consists of one coupling stage, three tuned

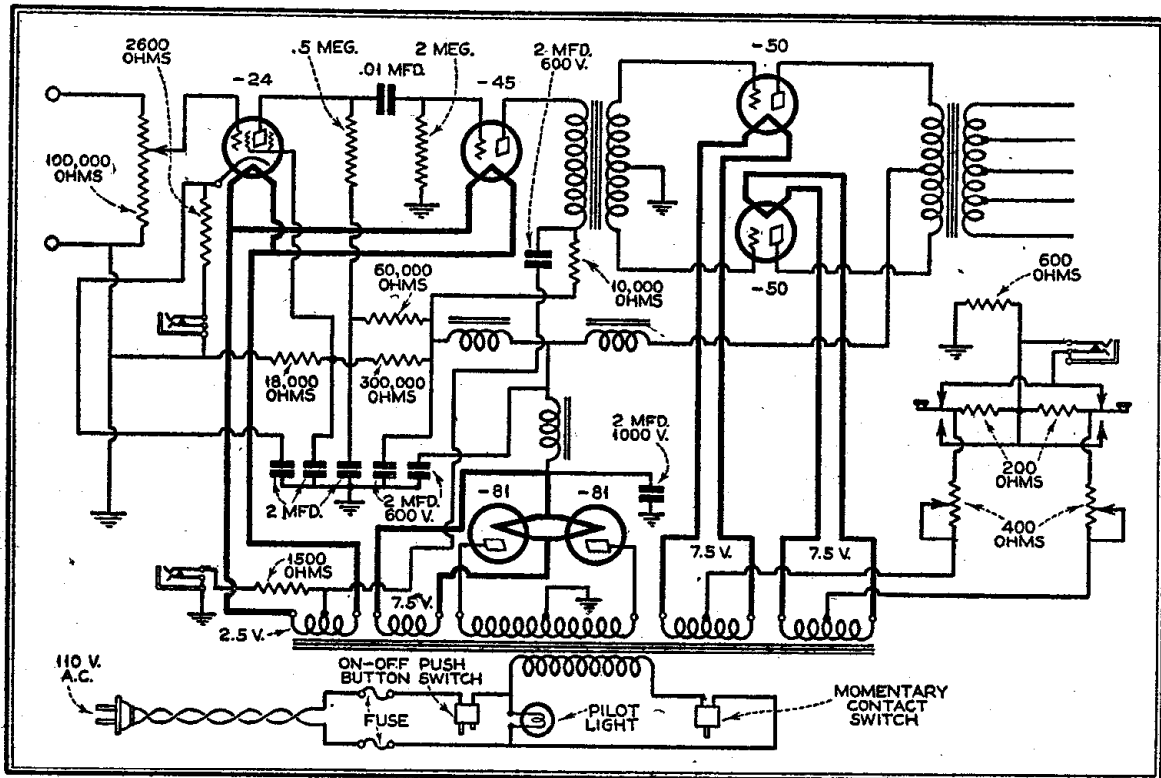

Circuit No. 71

A -80 full-wave rectifier supplies the plate potentials for the proper operation of this receiver. Plug-in coils permit the user to tune this set from 17 to 600 meters.

CIRCUIT No. 78 is that of the Silver screen-grid 30 radio receiver, where four screen-grid a.c. tubes are used, three of them functioning as high gain r.f. amplifiers, the fourth as a screen-grid power

radio frequency stages and two audio frequency stages. Screen-grid tubes of the a.c. type, powered from a d.c. source, are used in the coupling stage, first and second tuned radio frequency stages and in the first audio stage, as is also the -27 detector. The fuses in the A plus and B minus leads are extremely important and insure the wiring of the car against serious damage which may result from a reversed ground. The antenna

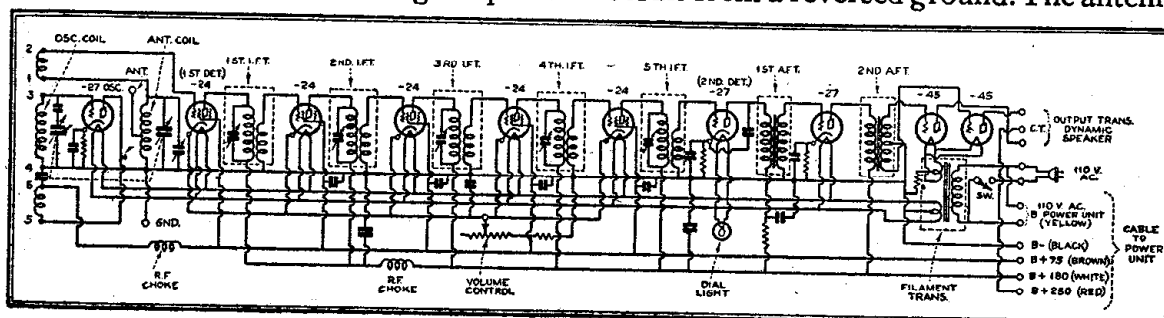

Circuit No. 72

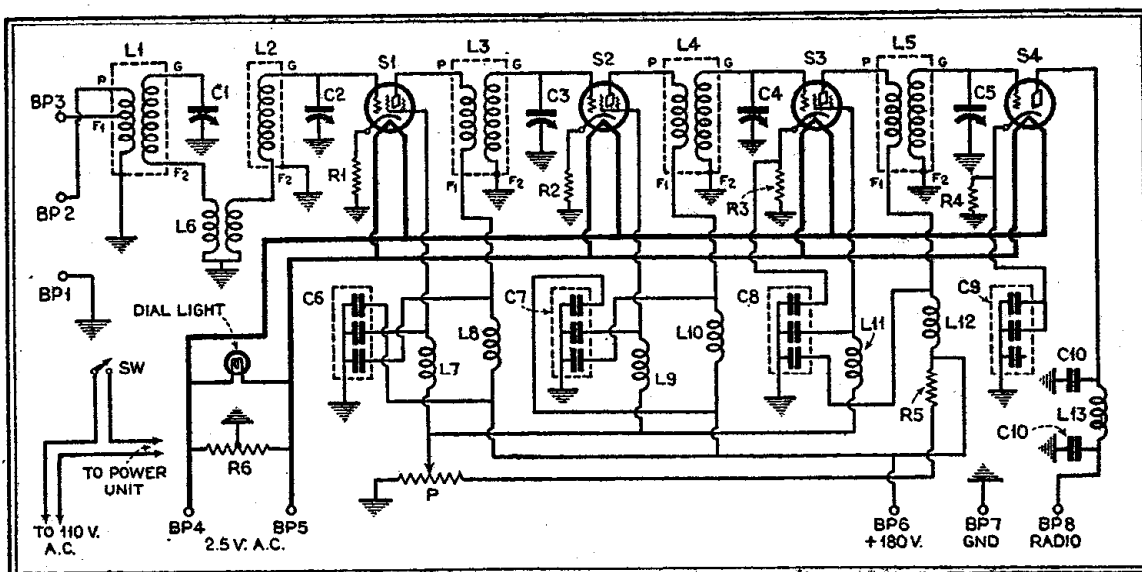

Circuit No. 73

is fed into the -24 tube through a 500,000 ohm resistance followed by the radio frequency amplifier, detector and audio amplifier systems. A receiver of this variety is intended for remote control operation by means of a flexible cable and accurately cut gears, having a ratio of 50 to 1.

Volume is controlled in this circuit by varying the filament voltage in current on the three radio frequency tubes. Grid suppressors are employed in the grid circuits in the two tuned radio frequency stages to eliminate any possibility of oscillation due to variation in tube characteristics.

CIRCUIT No. 80 is a schematic diagram of the Atwater Kent No. 35 for operation on 6-volt A supply and either B batteries or a B eliminator. The antenna feeds, in conjunction with a radio frequency choke, directly into the grid of a coupling tube followed by two tuned stages of radio frequency amplification and a tuned detector. The first stage audio employing the -01A tube and a second audio stage having a -71A power tube.

CIRCUIT No. 81 is a schematic diagram of the Victor Radio Models R32 and RE45. Ten tubes are required in both these models, six of them being the -26 type, one -27, two -45 power amplifier tubes and a full-wave -80. By means of a variable resistance, R10, shunted across the secondary of the push-pull input transformer control of tone is obtained so that the high or low audio frequencies may be accentuated as desired. The tuner, am-

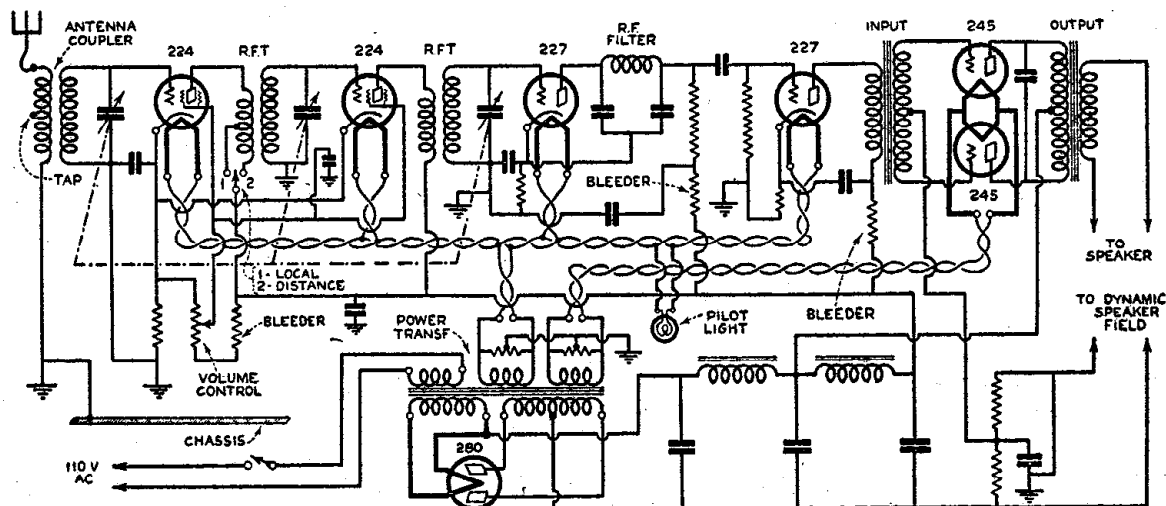

Circuit No. 74

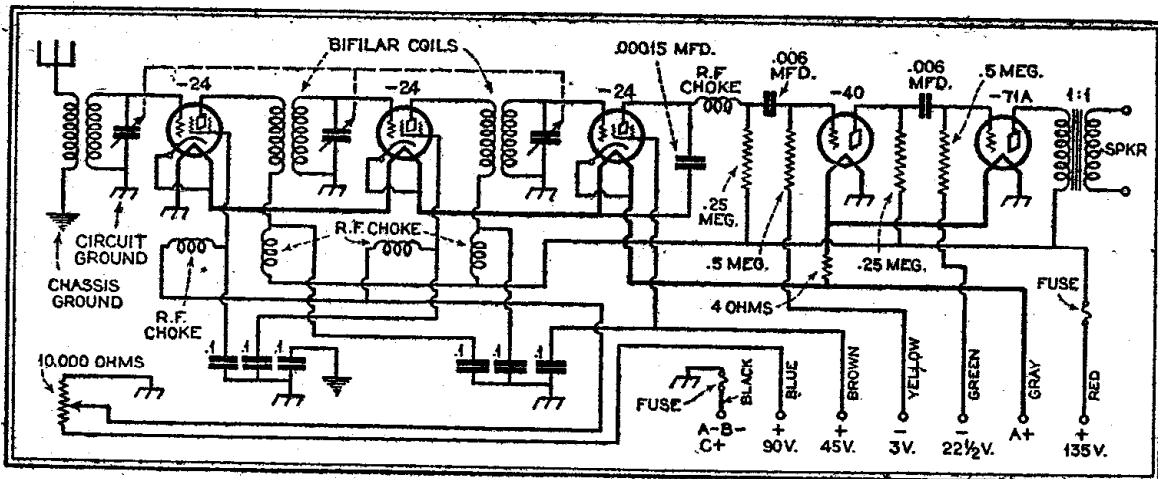

Circuit No. 75

plifier power supply and loud speaker are all wired separately and brought out to plug-in cables which connect to a terminal board, thus making installation a matter of simply plugging together three units. The model R32 is a radio receiver while the model RE-45 is a combination radio and electric phonograph.

Circuit No. 82 is that of the Stewart-Warner Series 950. Three -24 screen-grid tubes, two -27 a.c. heater type tubes, a pair of -45 output power amplifier tubes and a single -80 full-wave rectifier are the tubes which are employed in this a.c. operated receiver. Three screen-grid tubes

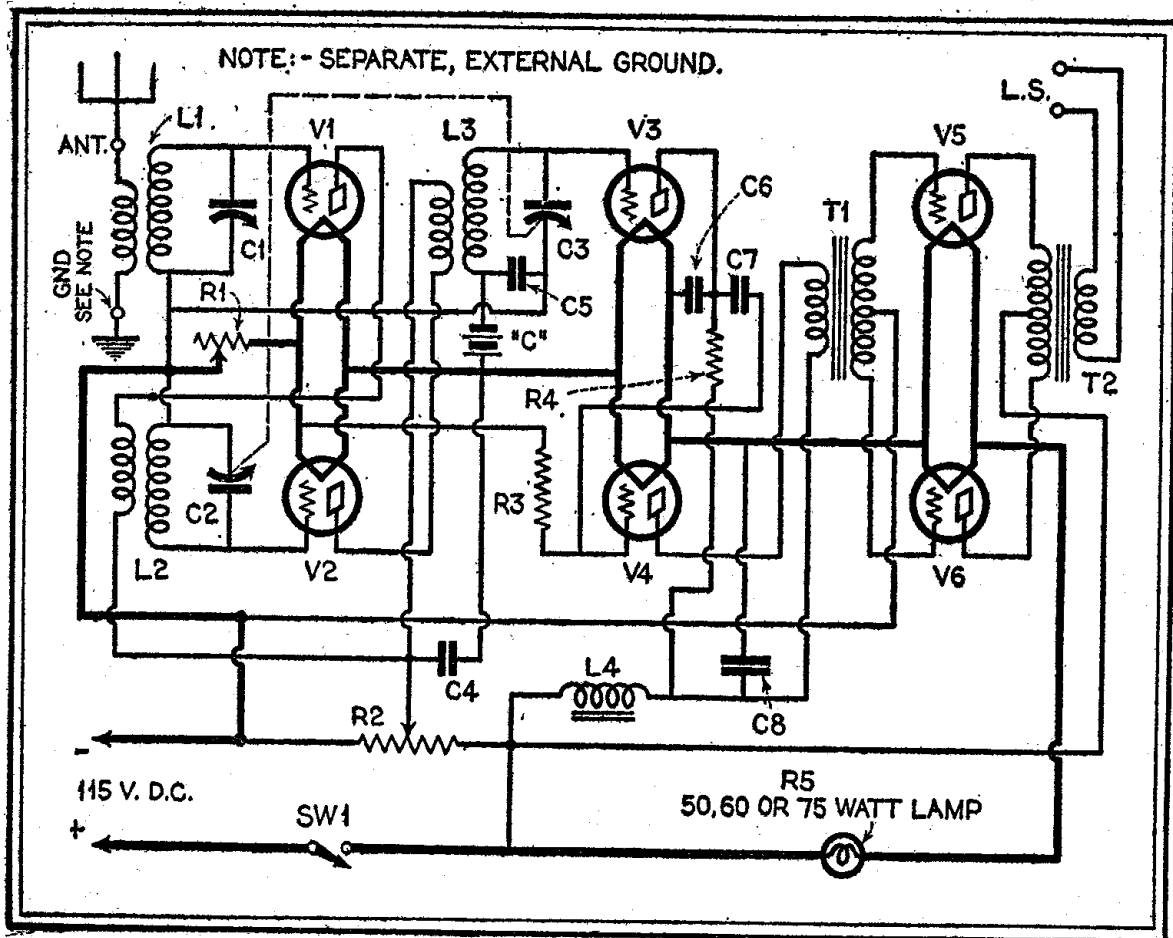

Circuit No. 76

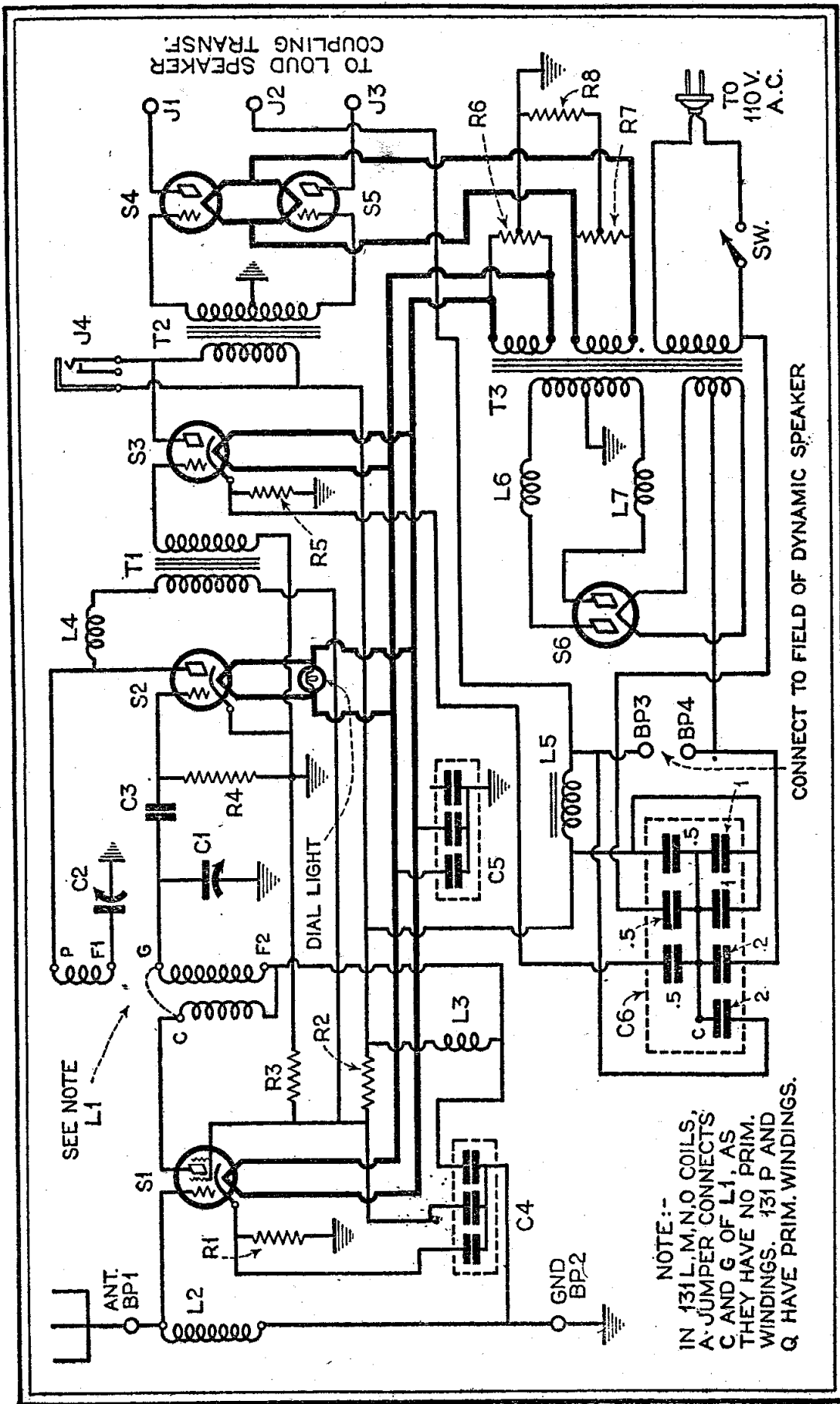

Circuit No. 77

are used in the three-stage radio frequency amplifier which is stabilized by the em-

ploying of neutralizing or stabilizing condensers. The tuning condensers are

shunted with equalizing capacities so that perfect alignment of this portion of the receiver is obtained. Coupling between the detector and first amplifier tubes, both -27 type tubes, is accomplished through the use of a resistance-coupling unit.

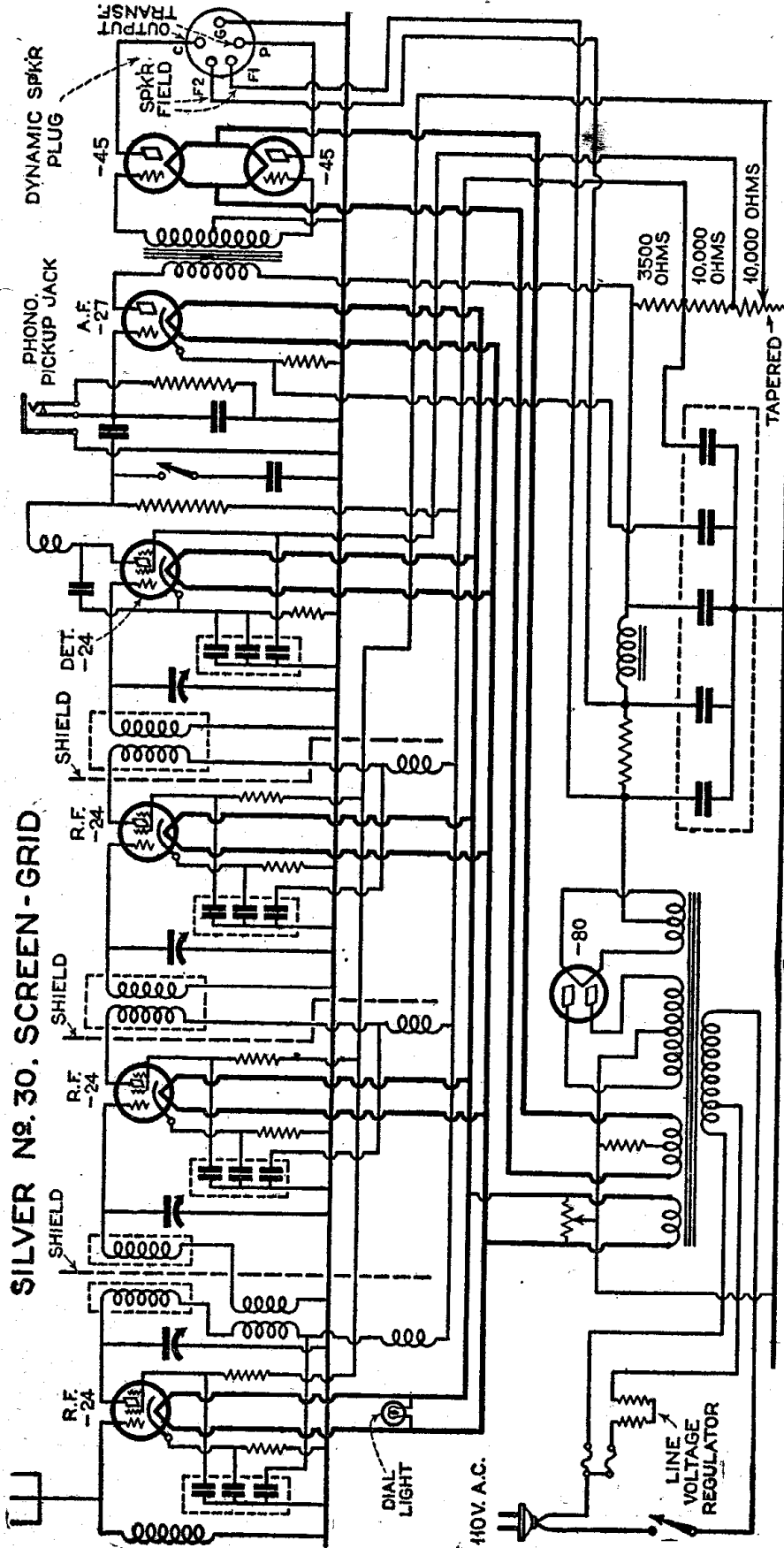

Circuit No. 78

CIRCUIT No. 83 is that of the Majestic No. 180 a.c. operated radio receiver. In this 7-tube receiver, two -50 tubes are arranged in push-pull providing exceptionally fine tone quality with little or no possibility of distortion, due to overloading. Five -27 tubes make up the remainder of the circuit, three being used as radio frequency amplifiers, one as a detector and one as a first stage audio frequency amplifier. A drum switch allows change-over from a radio program to the playing of phonograph records by connecting a phonograph pickup in the secondary circuit of the first audio frequency transformer.

CIRCUIT No. 84 is a schematic diagram of the Crosley No. 608 a.c. radio receiver. Three -26 tubes are employed in two stages

of tuned radio frequency and a first stage of audio frequency amplification, a -27 tube as a grid leak and condenser detector and a -71A tube in the second or out-put audio amplifying stage. A -80 tube is used to supply the plate potentials of this receiver while the filter system of the power supply employs the high capacity Mershon electrolytic condenser.

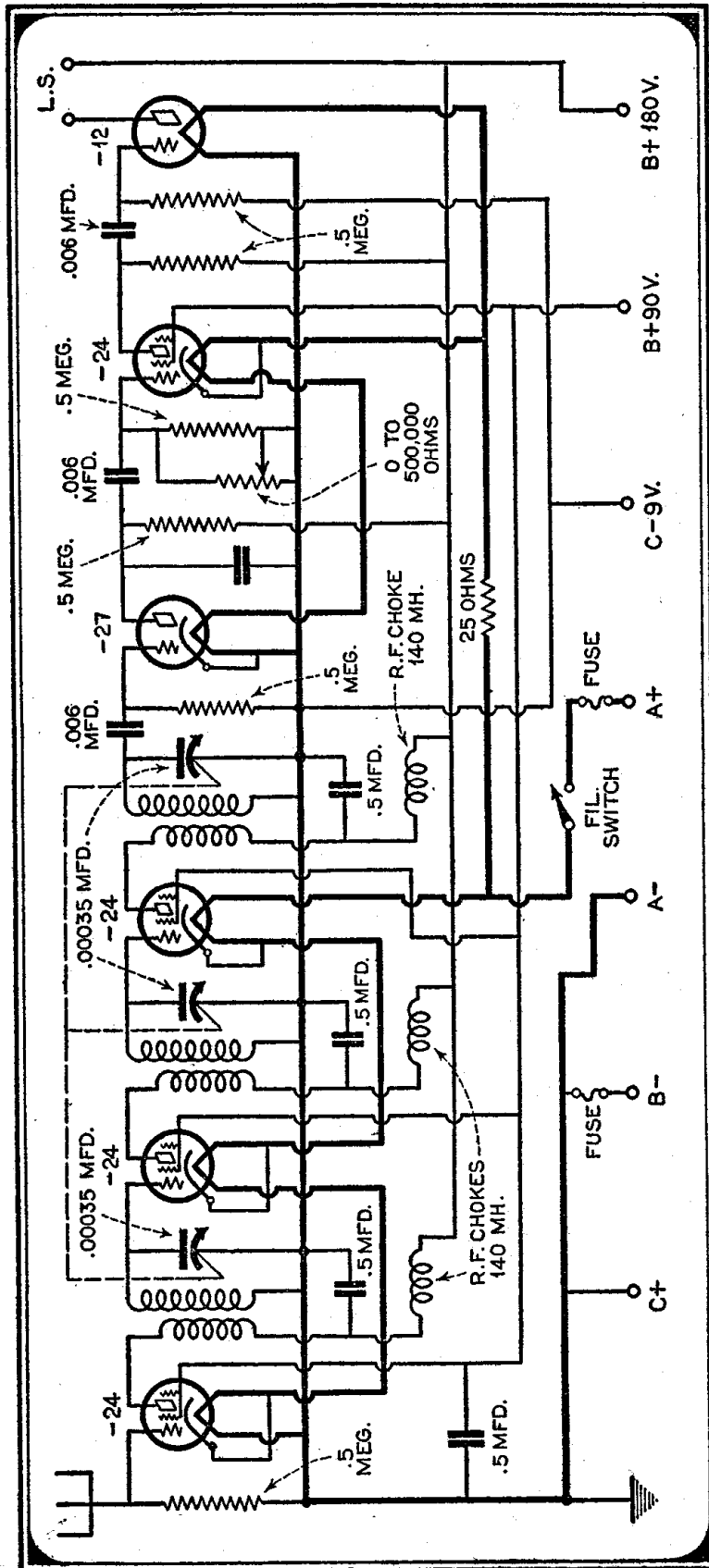

Circuit No. 79

CIRCUIT No. 85 is that of the Kolster K-21 receiver. The a.c. filament type of tube, otherwise known as the -26, is used in the antenna coupling stage and three tuned radio frequency amplifier stages of the Kolster Series K-21. The heater type a.c. tube -27 is used in the detector stage. These five tubes complete the tuner portion of the receiver and are constructed as a separate unit. The audio amplifier consisting of two transformer stages and power supply unit comprise the second unit of the receiver. The first audio stage employs a -26 tube while the final audio stage makes use of the -71A. Provision has been made for plugging in a phonograph pickup for the reproduction of phonograph music.

CIRCUIT No. 86 is that of the Pilot a.c. short-wave Super-Wasp receiver. The circuit diagram is of a 4-tube receiver with its associated power supply unit. The tube equipment necessary for correct operation of this receiver includes -24 a.c. screen-grid, two -27 indirect heater type tubes as first and second audio amplifiers, a

Continental Auto Receiver

-80 full-wave rectifier supplying plate potentials and a -27 Pilotron as a detector. Tuning is accomplished by two main tun-

ing dials for the .00016 mfd. condensers while regeneration is controlled by the condenser in the plate circuit of the detector tube.

ATWATER-KENT No. 35

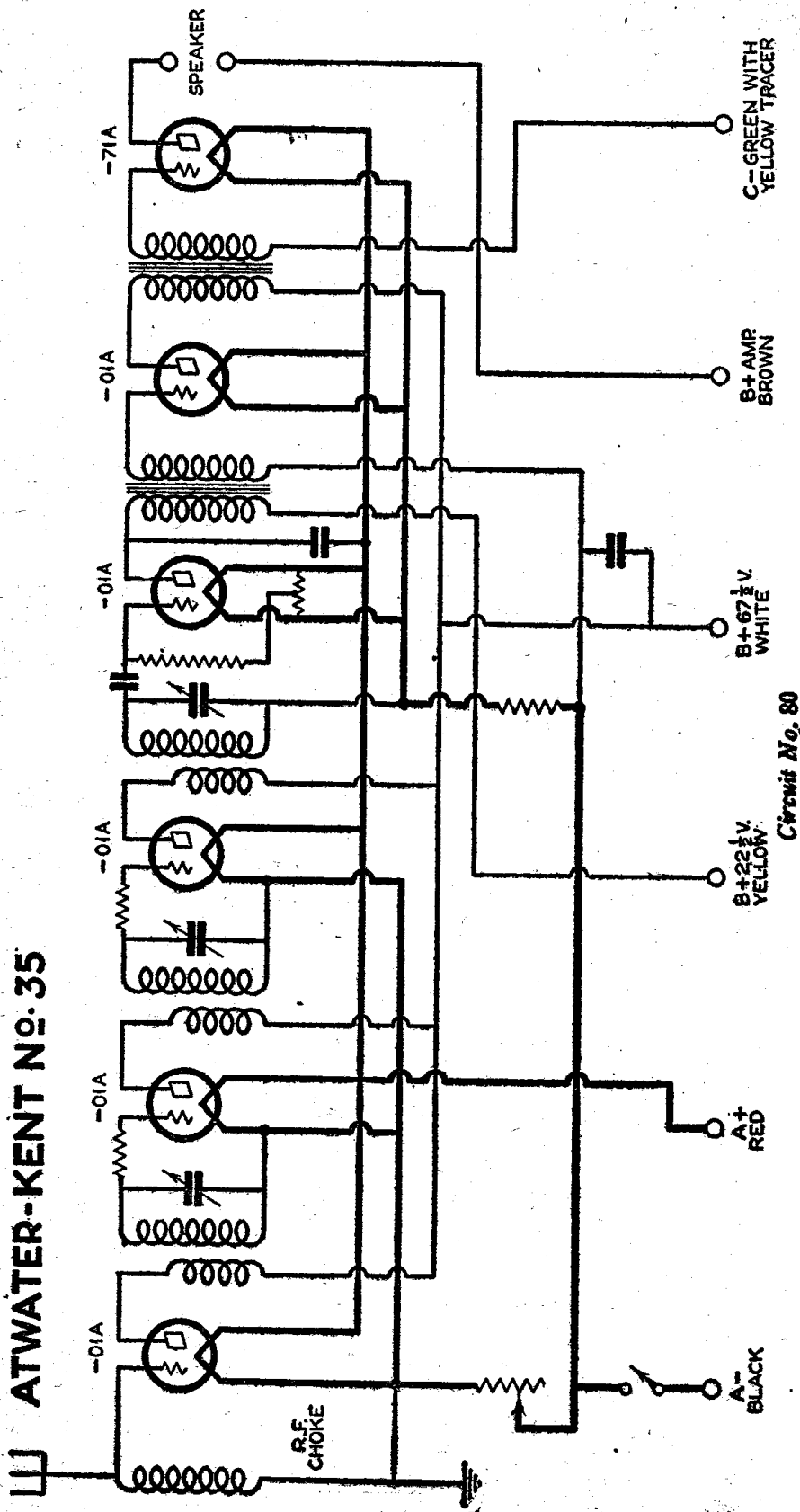

Circuit No. 87 is a schematic diagram of the Pilot PE6 radio receiver employing two a.c. screen-grid tubes in the tuned radio frequency stages, a -27 in the detector and the first audio stage, and a pair of -71A's in the push-pull audio amplifier, while a -80 full-wave rectifier supplies the B voltages. Single dial control is effected in this circuit by employing a three-gang condenser each having a very small trimming condenser shunted across its rotor and stator connections.

Circuit No. 88 is that of the Jackson NJ-30 radio receiver. As is evident from the circuit diagram No. 88 the audio channel is resistance-coupled throughout. It is most interesting. A -24 tube is operated as a space-charge amplifier. This means that the usual grid connections are reversed. The signal is impressed on the outer screen-grid and a fixed voltage is impressed on the

inner grid. This gives a very high gain (about 60) so that only two stages are necessary. The second stage is a -45 out-

put tube. Although both tubes are supplied from the same B supply tap, the -24 is coupled through a 500,000 ohm resistor

which provides the necessary impedance in the plate circuit and cuts down the voltage for the plate. Another interesting feature is that all filaments are supplied from the same transformer windings. If this were done with tubes connected in the usual way, it would impress a voltage between the cathode and filament of the heater tubes. This potential would be equal to the grid bias voltage of the -45 tube which is 10 times the maximum value that can be safely impressed. To avoid this the filament and cathodes of all tubes are operated at approximately ground potential and the B minus is operated at 50 volts below ground.

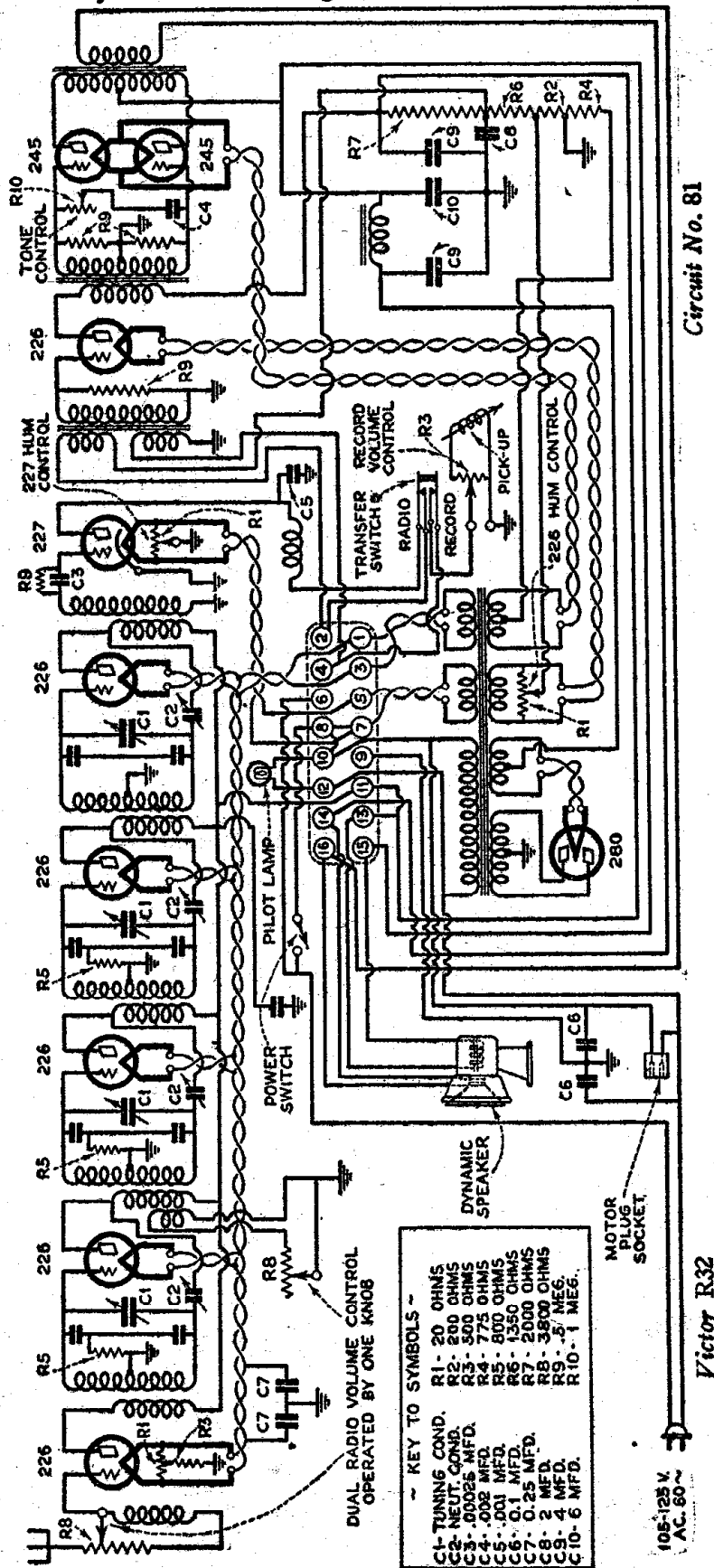

CIRCUIT No. 89 is that of the Freshman Q15 a.c. operated radio receiver. In this circuit the first tube -22, a d.c. operated screen-grid tube, is used in the a.c. circuit having 3.1 volts raw a.c. filament, followed by a -27 tube as a detector, a -26 as a first transformer-coupled audio stage and a -71 as an output stage, also transformer-coupled. B potentials are obtained from a -80 full-wave rectifier tube and the conventional filter circuit employing an audio frequency choke coil and filter condensers. By means of two resistors, the correct operating voltage is supplied to the screen-grid of the radio frequency choke and the plate of the detector tube. Single dial control is effected by em-

playing the stator plates of the two variable condensers at ground potential.

CIRCUIT No. 90 is a schematic diagram of the Fada No. 35B radio receiver, a.c.

operated, embodying the following features. First, four tuned stabilized circuits; second, power detection; third, high quality two stage audio channel employing push-pull in the final stage; fourth, eight tubes as follows, 3-24, 2-27,

2-50, 1-80; fifth, provision for phonograph pickup attachment.

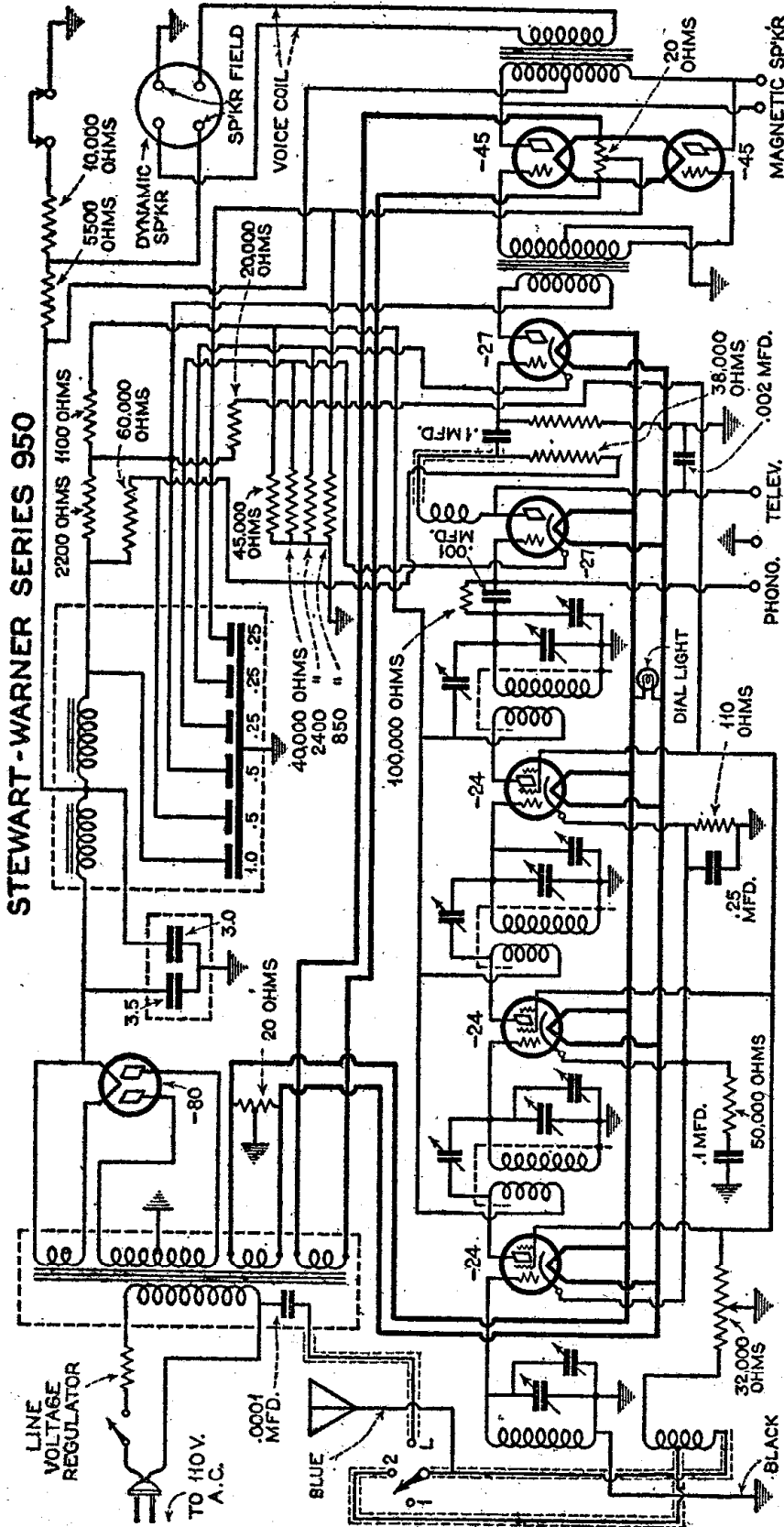

Circuit No. 82

CIRCUIT No. 91 is a schematic diagram of the Bosch No. 48 radio receiver comprising of three stages of tuned radio frequency, making use of screen-grid -24 tubes, power detector, a -27 indirect heater type tube and followed by a pair of -45 in push-pull combination. Due to the extremely high gain obtained in the radio frequency portion of the receiver, it has been found unnecessary to use the conventional two stages of audio amplification. A -80 tube provides full-wave rectification in the power pack.

CIRCUIT No. 92 is a schematic diagram of the Grebe d.c. No. SK-4 radio receiver. This receiver for operation on the d.c. lighting circuit employs three -24 screen-grid tubes as radio frequency amplifiers, -27's as detector and first audio and a pair of -45's in the final audio stage. C potentials are obtained

MAJESTIC No. 180

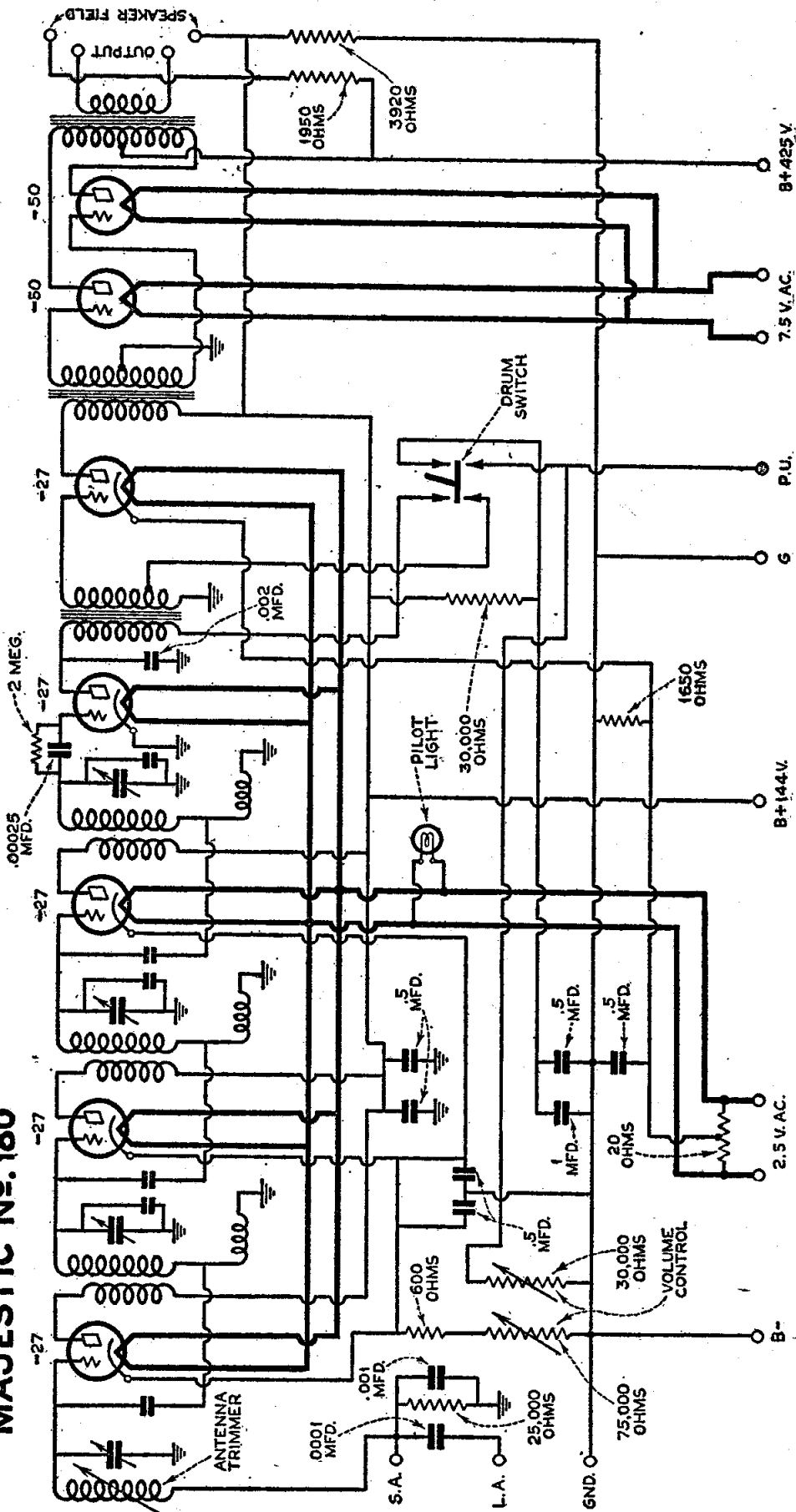

Circuit No. 83

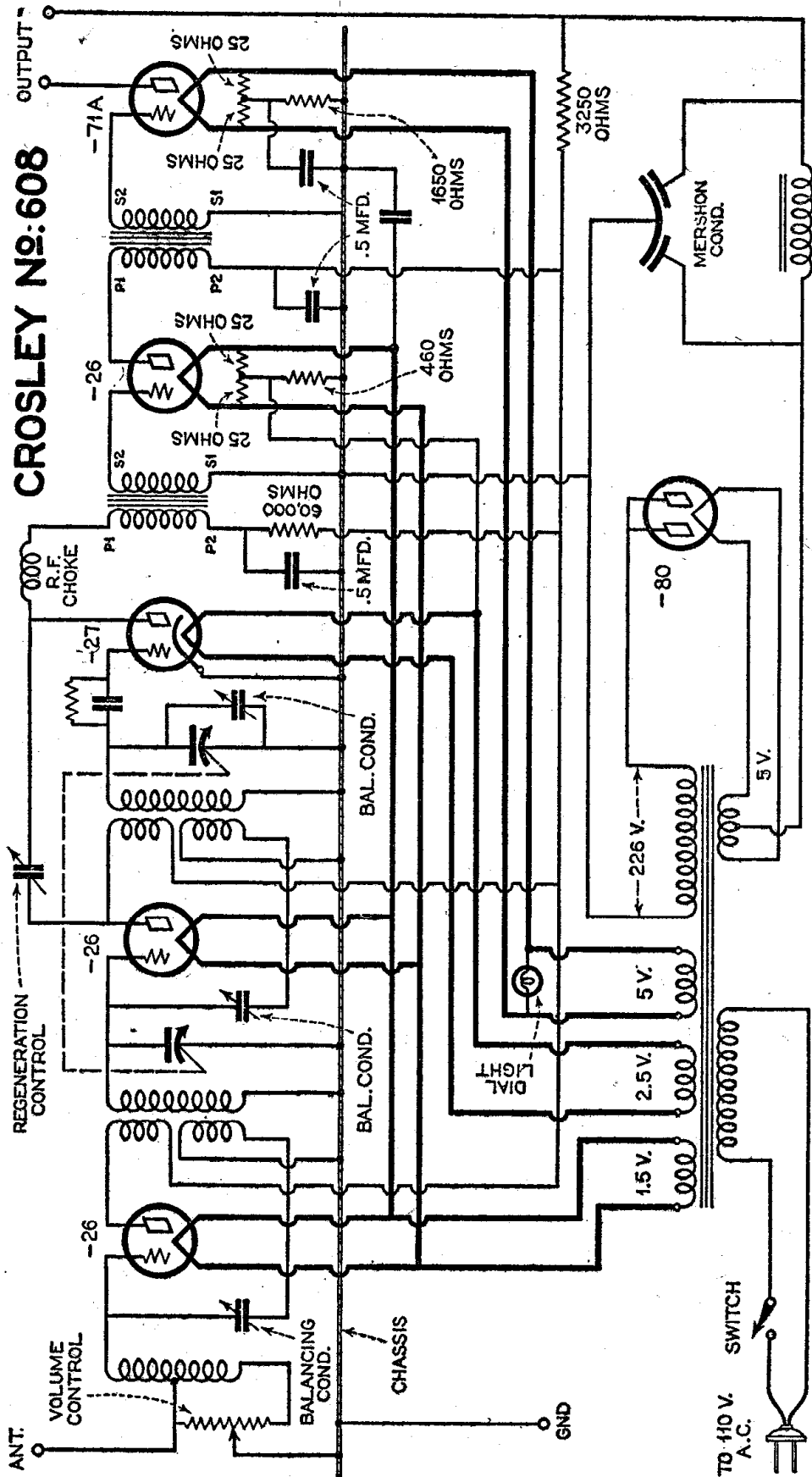

KOLSTER SERIES K-21

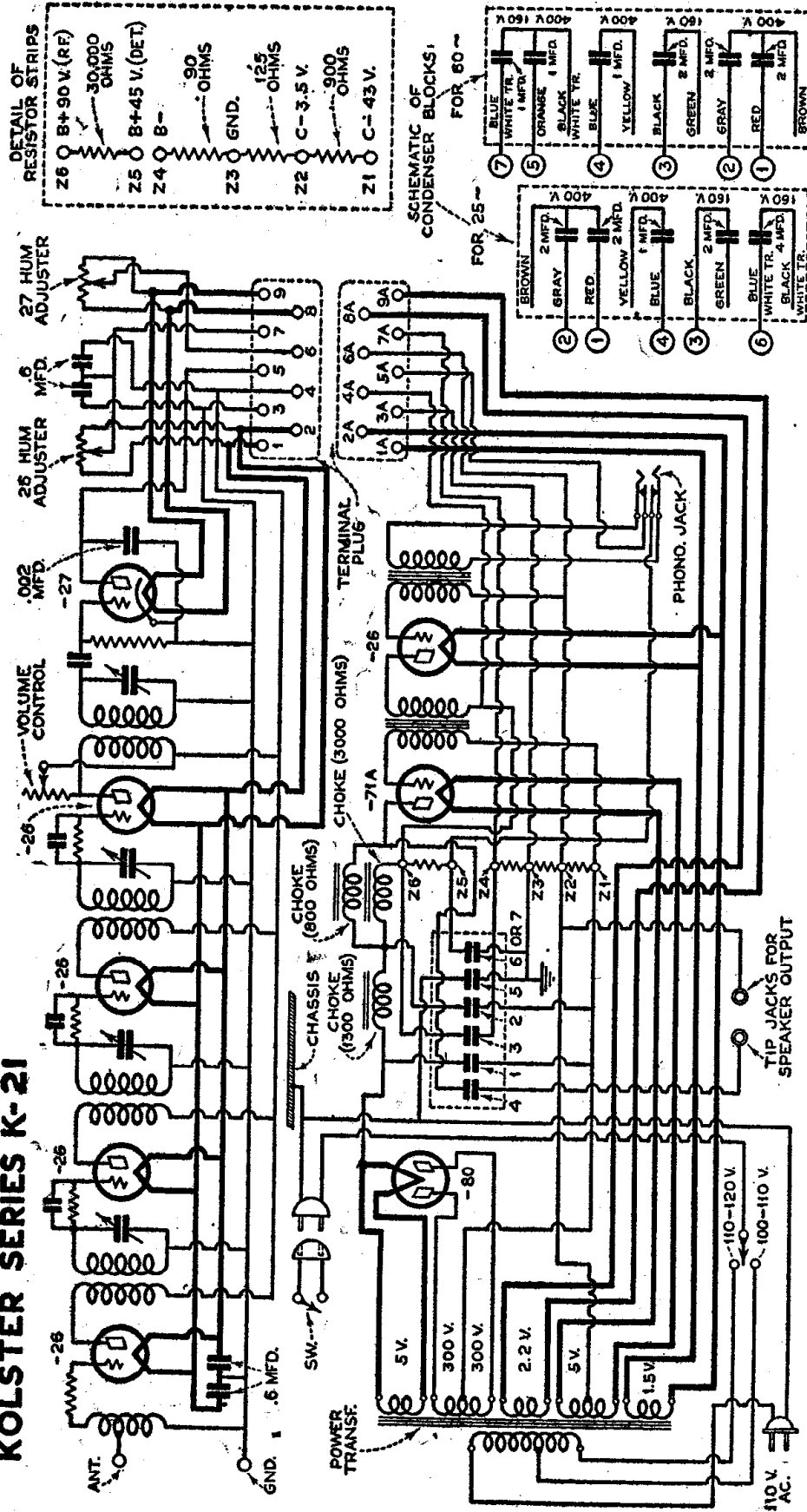

Circuit No. 85

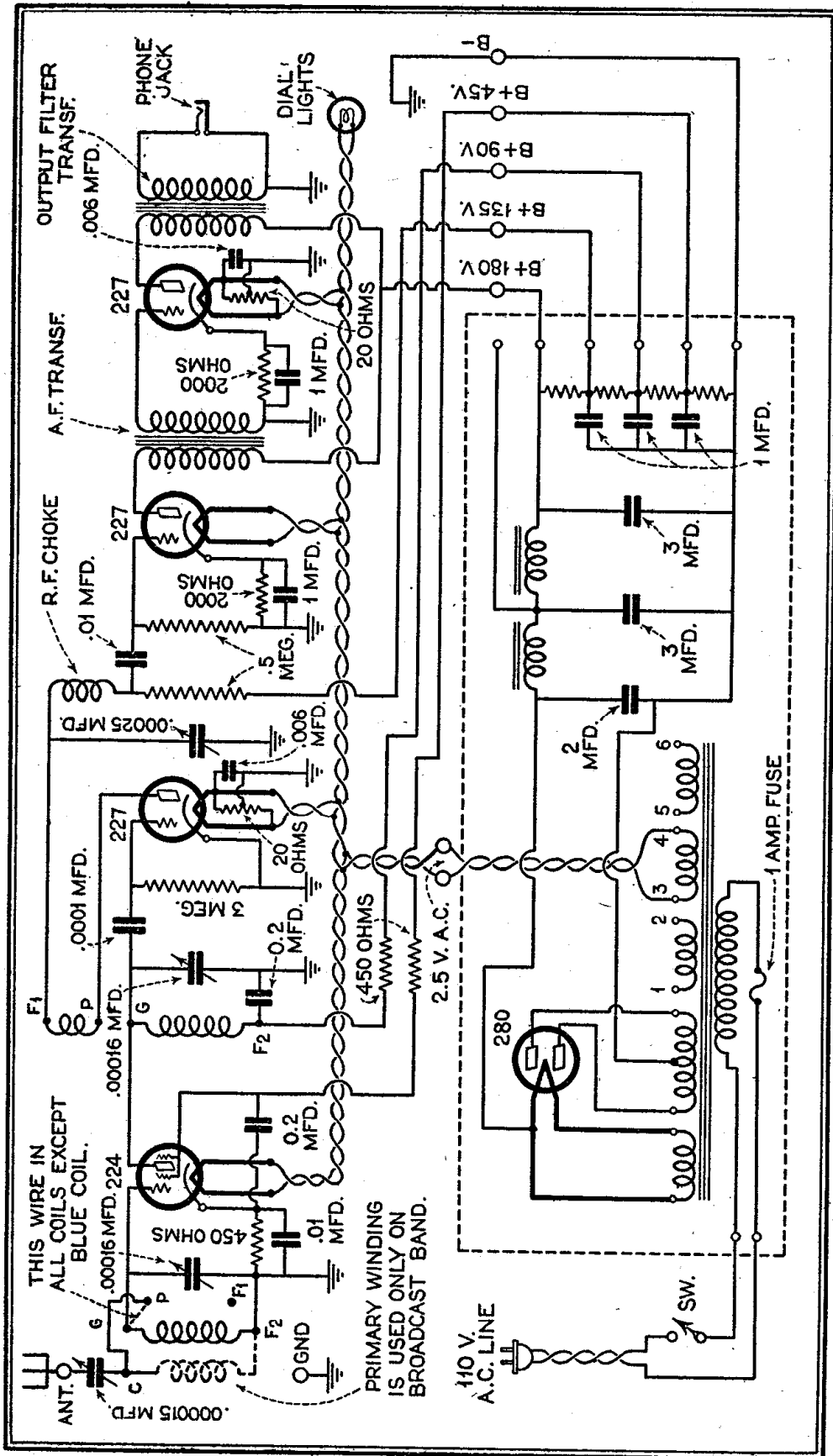

Circuit No. 86
Pilot A.C. Super Wasp

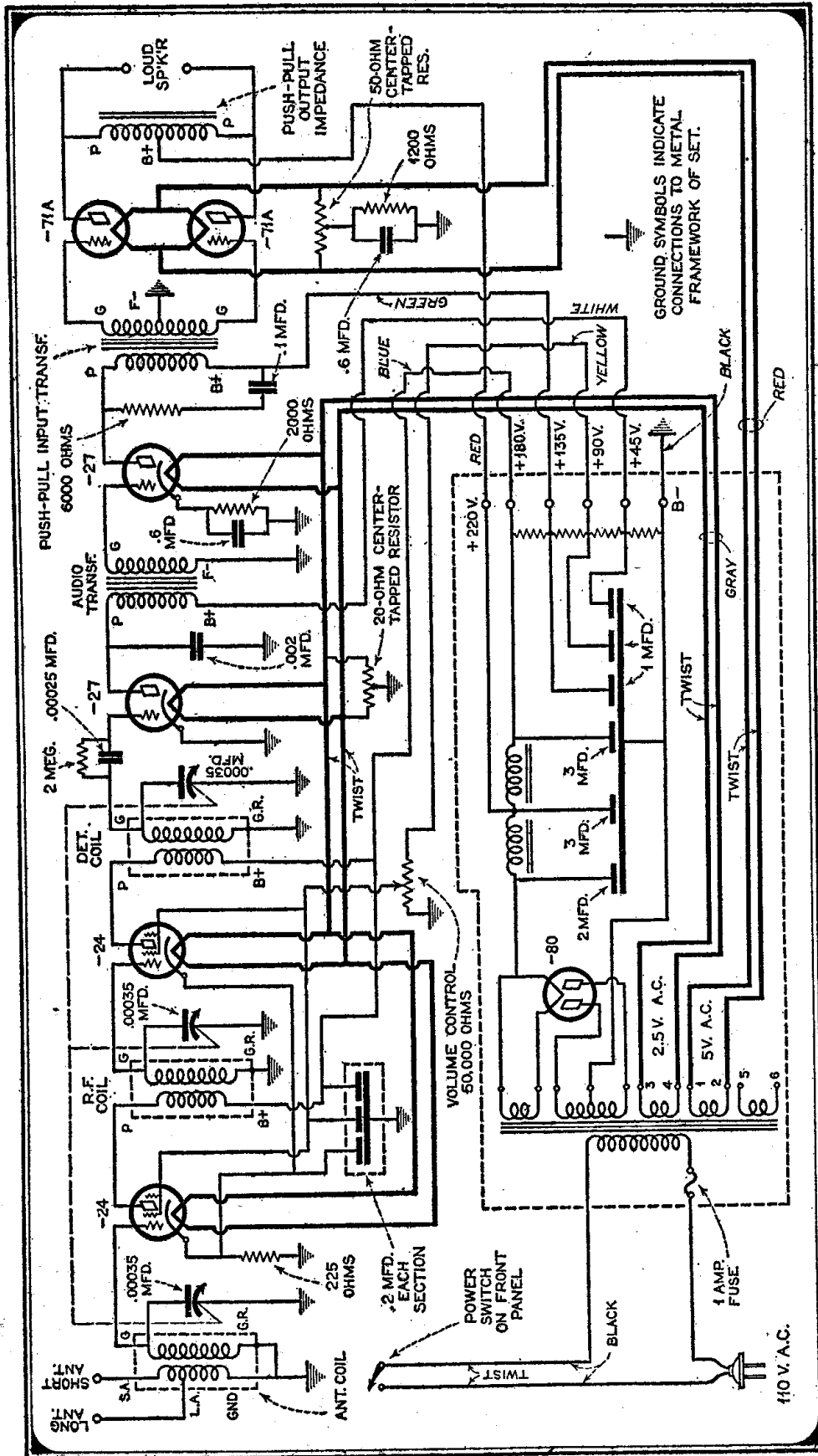

Circuit No. 87
Pilot PE 6

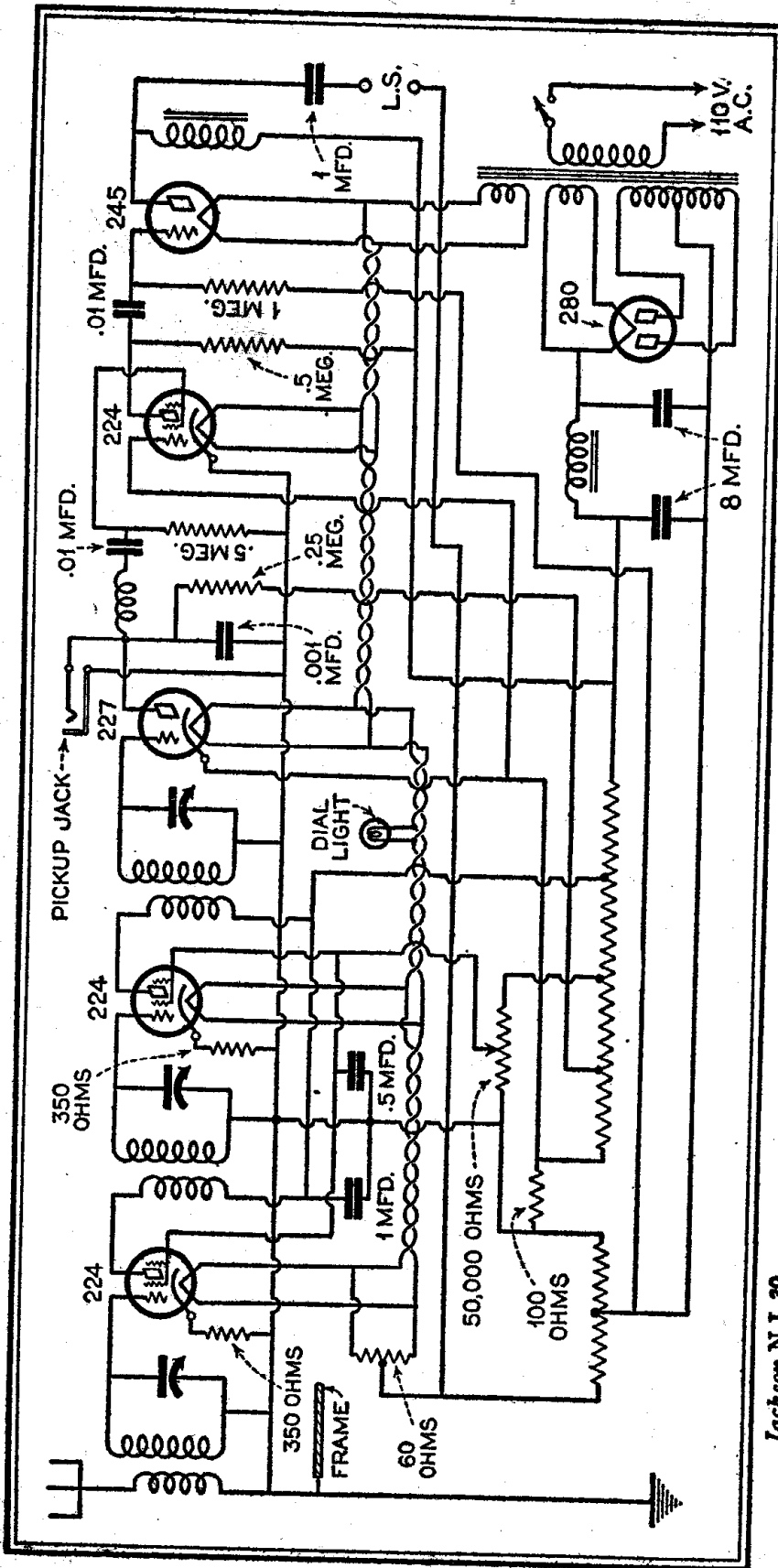

Circuit No. 88

through the use of the conventional dry C battery, thus permitting the full 110 volts d.c. to be impressed on the plates of the -45 tubes. Provision has also been made in this receiver for the connection of a phonograph pickup unit for the playing, electrically, phonograph records using the audio amplifier and dynamic speaker. In using this d.c. receiver or any other, attention must be paid to the insertion of the attachment plug so that the positive terminal connects with the positive side of the line.

CIRCUIT No. 93 is that of the Hammarlund Roberts HiQ 30. radio receiver employing three stages of band selector three stages of radio frequency amplification using the -24 high gain screen-grid tubes, -27 tubes as detector and first audio and a pair of -45's in push-pull transformer-coupled audio stage. The power supply requires full-wave rectifier tube -80 as well as a regulator tube, eliminating B. potential fluctuations from varia-

Jackson N.J. 30

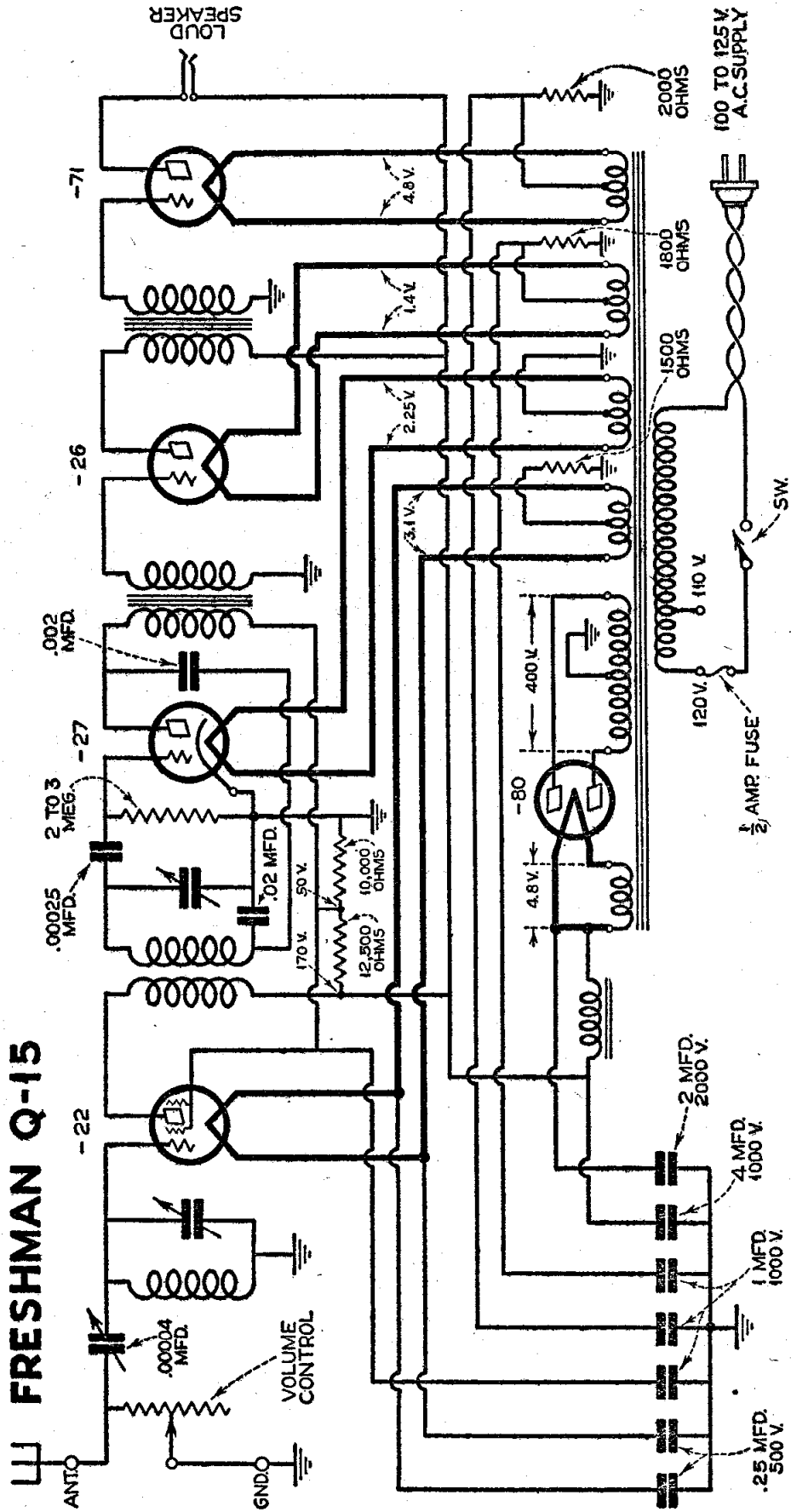

FRESHMAN Q-15

Circuit No. 89

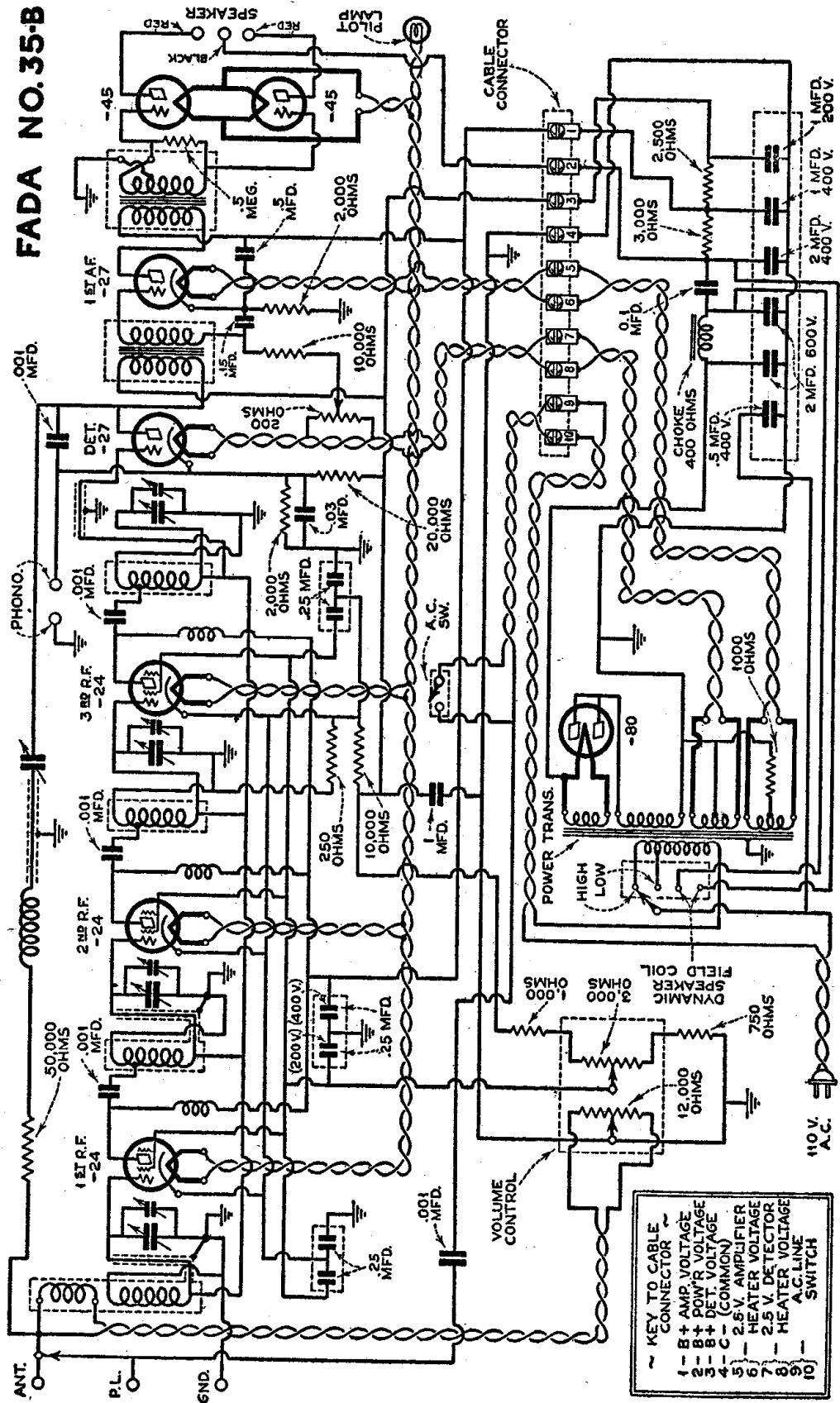

FADA NO. 35-B

- KEY TO CABLE CONNECTOR
- 1 - B+ AMP VOLTAGE
 - 2 - B+ POW'R VOLTAGE
 - 3 - B+ DET. VOLTAGE
 - 4 - C - (COMMON)
 - 5 - 2.5V. AMPLIFIER HEATER VOLTAGE
 - 6 - 2.5V. DETECTOR HEATER VOLTAGE
 - 7 - 2.5V. DETECTOR HEATER VOLTAGE
 - 8 - 2.5V. DETECTOR HEATER VOLUME CONTROL
 - 9 - A.C. LINE SWITCH
 - 10 -

Circuit No. 90

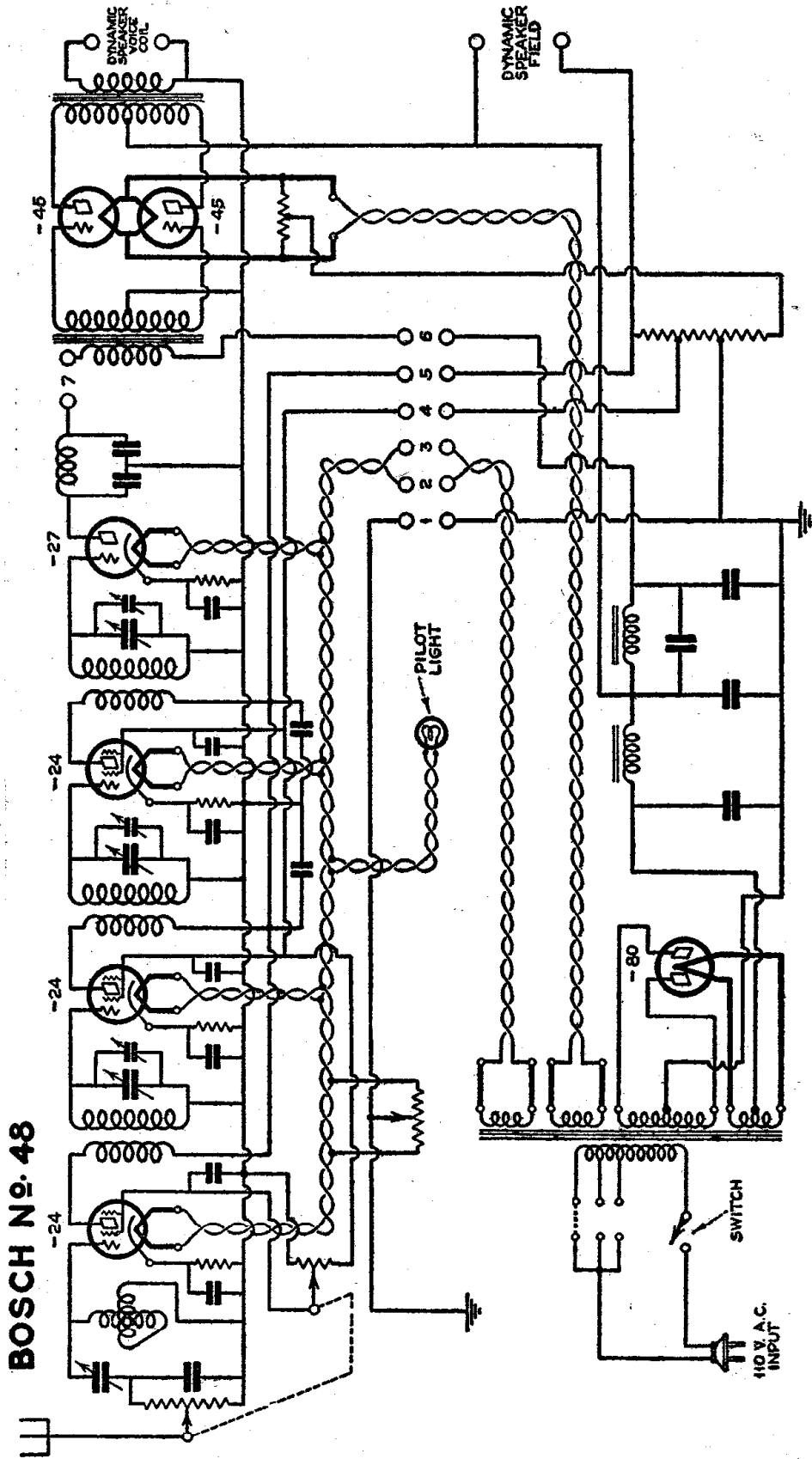

BOSCH No. 48

Circuit No. 91

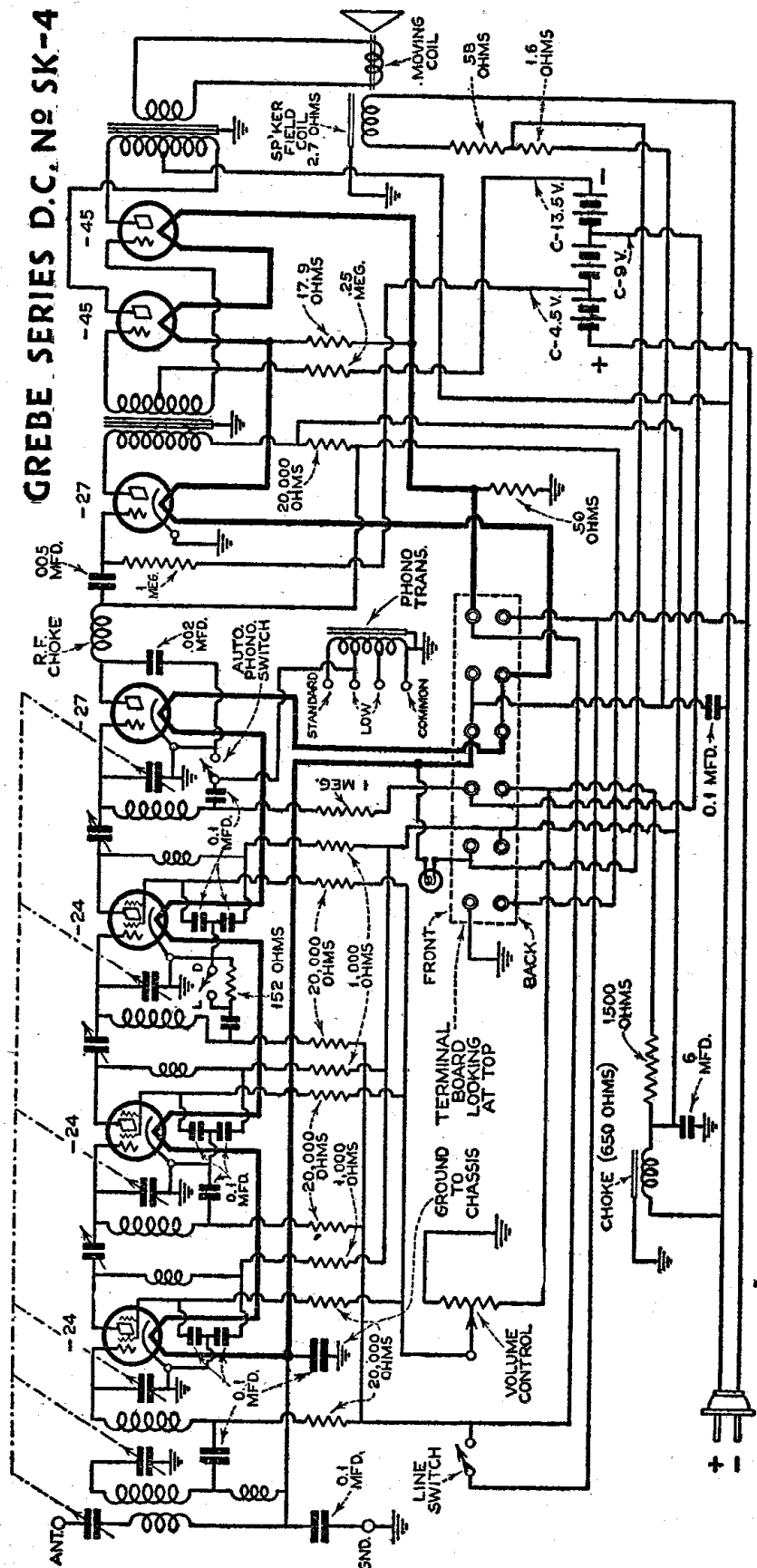

Circuit No. 92

tions in the 110 volt a.c. lighting circuit.

Circuit No. 94 is a schematic diagram of the Zenith 34P and 342P, a.c. operated radio receiver. This circuit employs five -27 indirect heater type tubes in three stages of radio frequency amplification, detector and a first transformer-coupled audio stage, followed by a -10 tube in the final output audio stage. Antenna resonance is effected permitting single dial control by a tunable coil in the secondary of the first tuned inductance circuit. Volume is controlled by varying the plate potentials on the second and third radio frequency tubes. This radio receiver is intended for operation in conjunction with one of

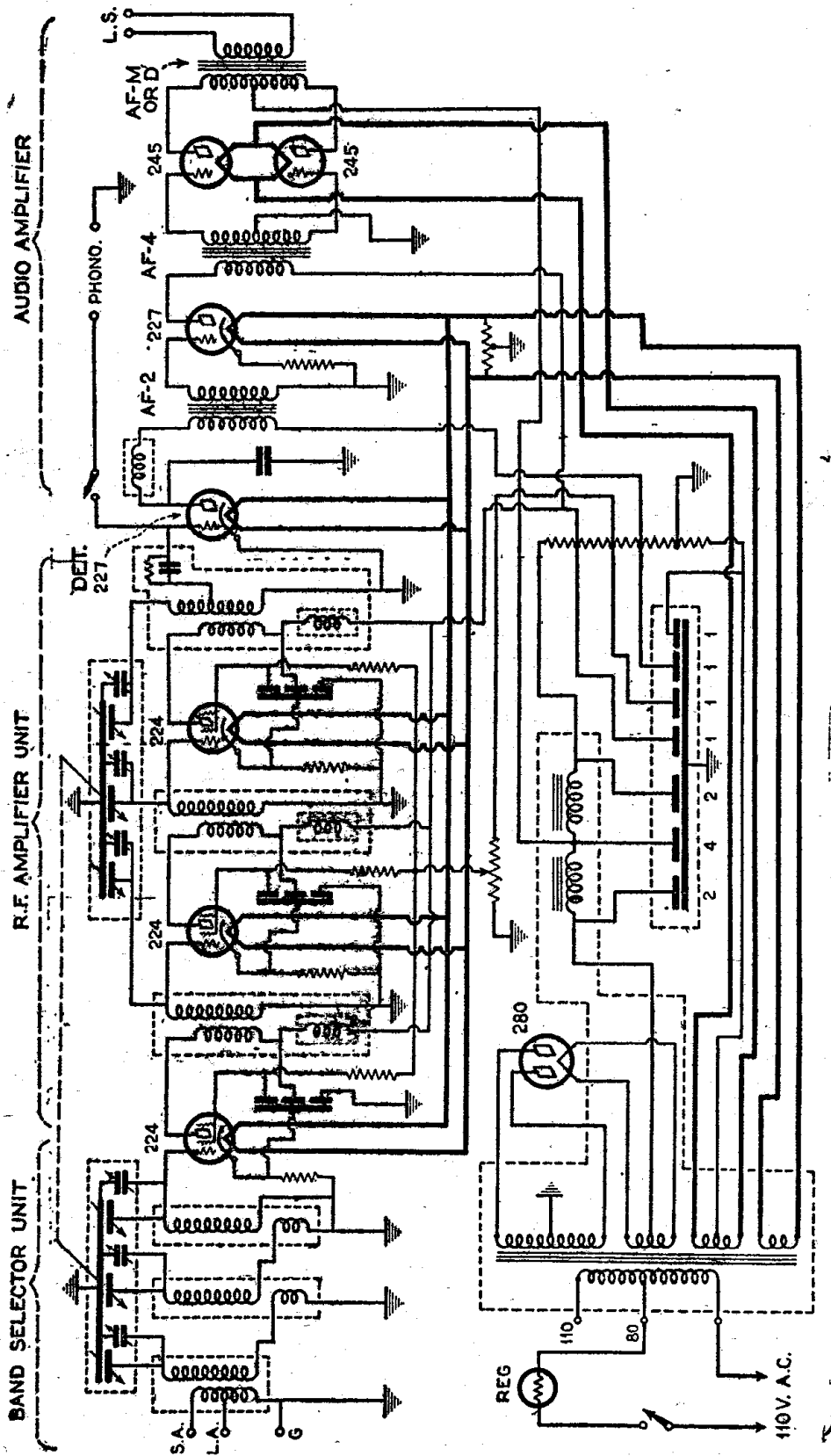

POWER SUPPLY
Circuit No. 93
Hammarlund "Hi-Q30"

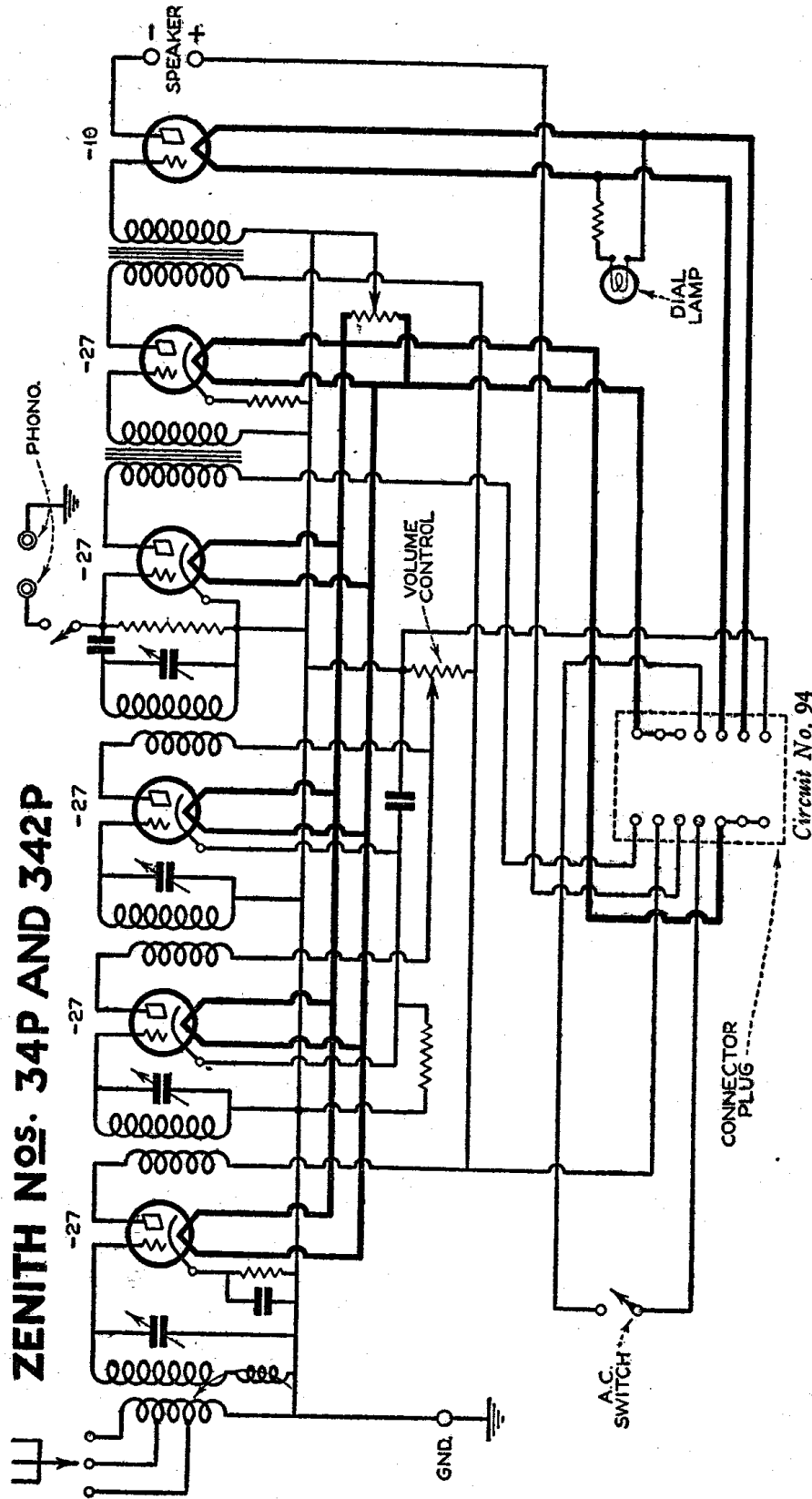

ZENITH NOS. 34P AND 342P

the standard Zenith power packs, whose connections, in cable form, terminate at the connector plug of the radio receiver chassis. Provision has been made in this circuit for a phonograph pick-up for electrically playing phonograph records, making use of the detector, first audio and second audio tubes.

CIRCUIT No. 95, the Stromberg-Carlson model No. 635-36, five -27 indirect heater type tubes are employed in three stages of radio frequency amplification, detector and first audio, while a single -71A

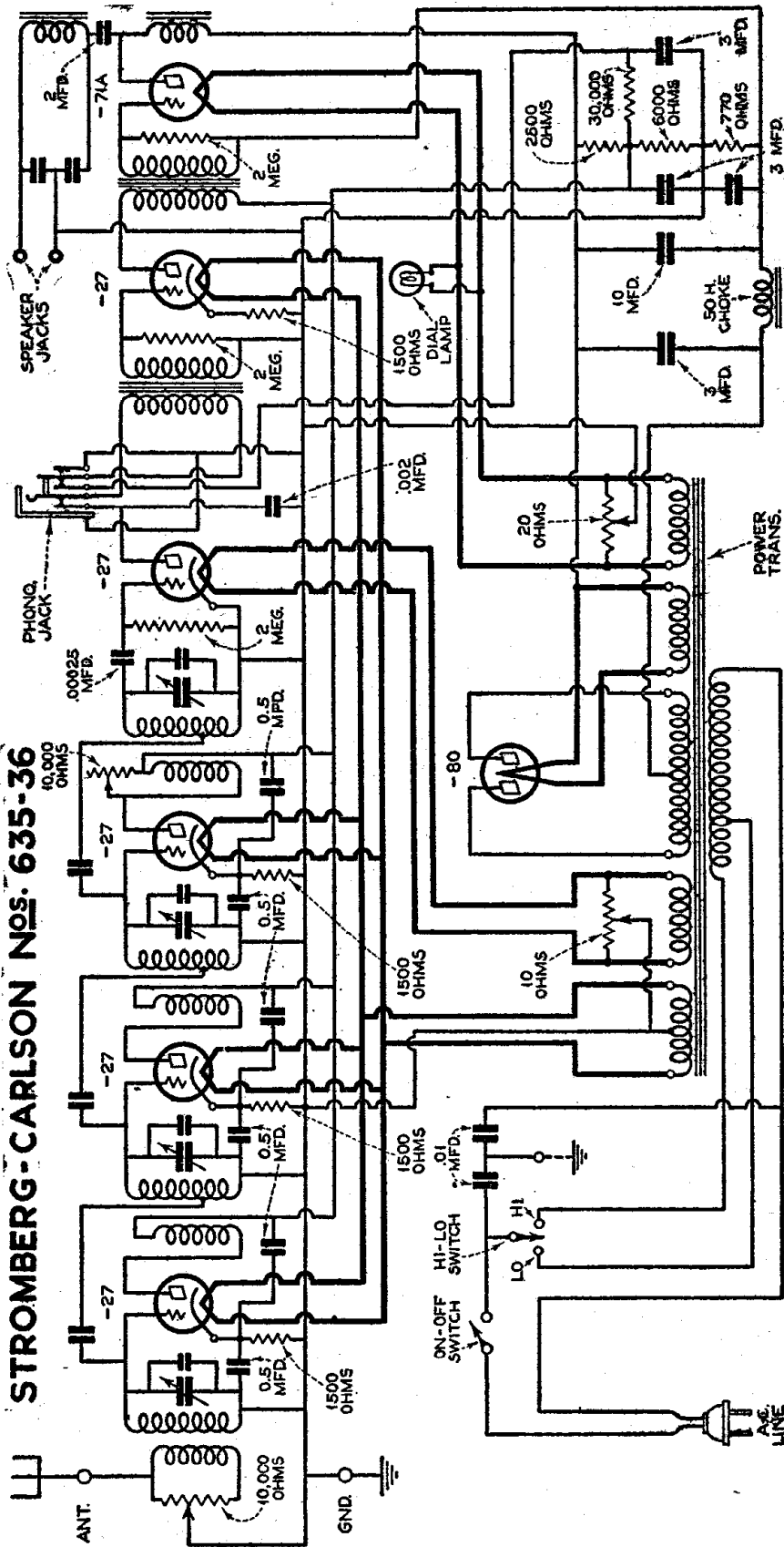

STROMBERG-CARLSON Nos. 635-36

Circuit No. 95

tube is used in the second or output audio frequency stage. A full-wave rectifier -80 tube is employed in the "B" supply. Stabilization is effected by use of a modified neutralized radio frequency circuit. Provision has been made in this receiver for an external phono-pickup.

The Stromberg - Carlson screen-grid receiver No. 641 (circuit No. 96) employs complete shielding. As a means of stabilizing the radio-frequency circuits four filter condensers in groups of two, arranged in series-parallel are in each of the r.f. amplifier stages, to provide a bypass for the screen-grid and plate circuits of each of these amplifiers.

The six tubes required for this radio receiver are as follows: three

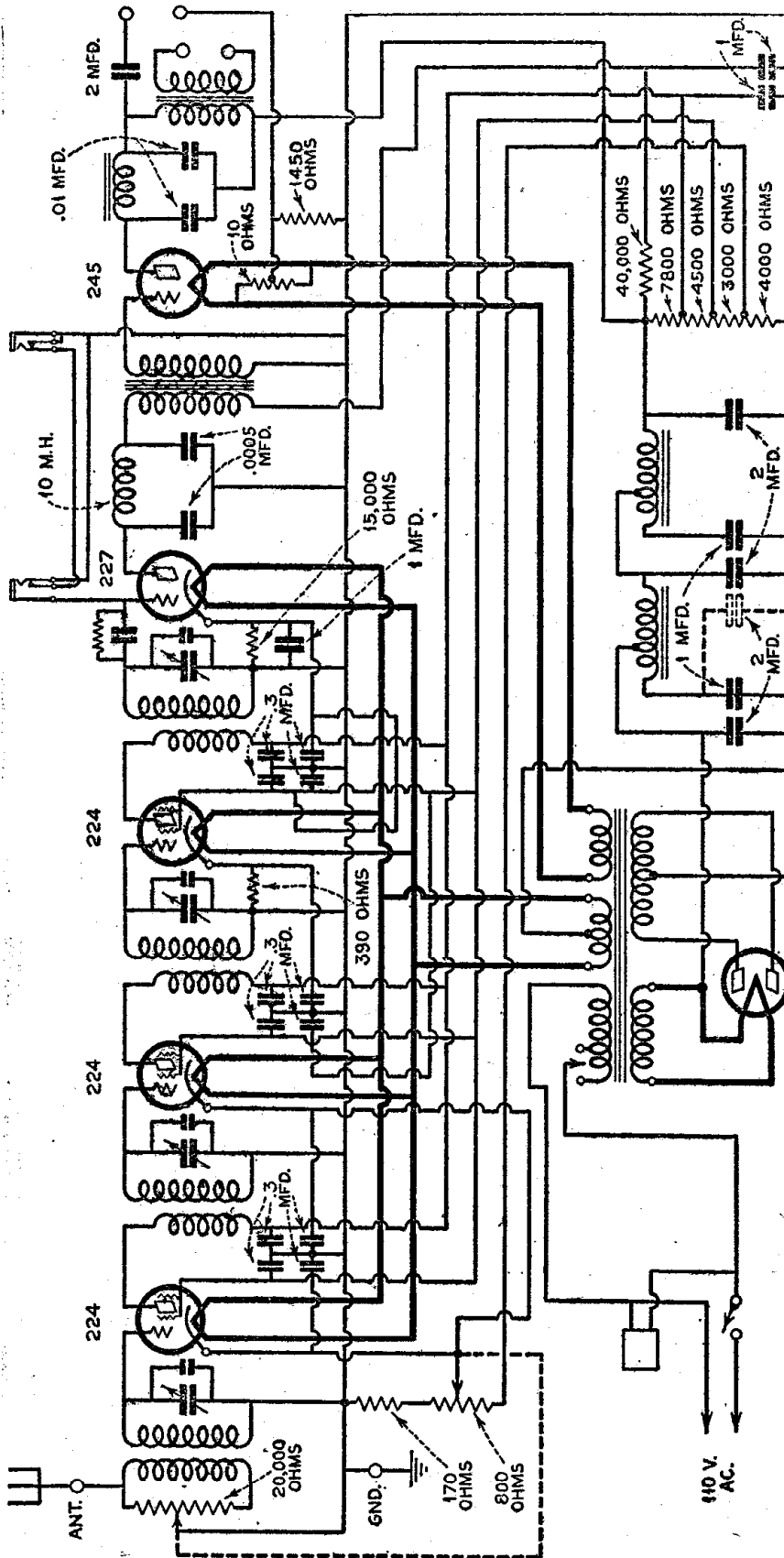

Circuit No. 96

Stromberg-Carlson 641

-24, one each
-27, -45 and
-80.

In the Colonial Model SG32 a.c. receiver (circuit No. 97) four sharply tuned circuits which are totally shielded from each other are "staggered" to secure a flat-top resonance curve. Automatic regulation of the audio channel allows equal quality of reproduction on both the low and high volume. The tuner comprises four shielded and filtered stages of high gain radio frequency amplification, employing four a.c. screen-grid tubes, one of which is used in the power-detector stage. The detector outputs to a resistance-coupled first audio stage employing the -27 type tube. The final audio stage comprises a power-amplifier employing two -45 tubes arranged in push-pull.

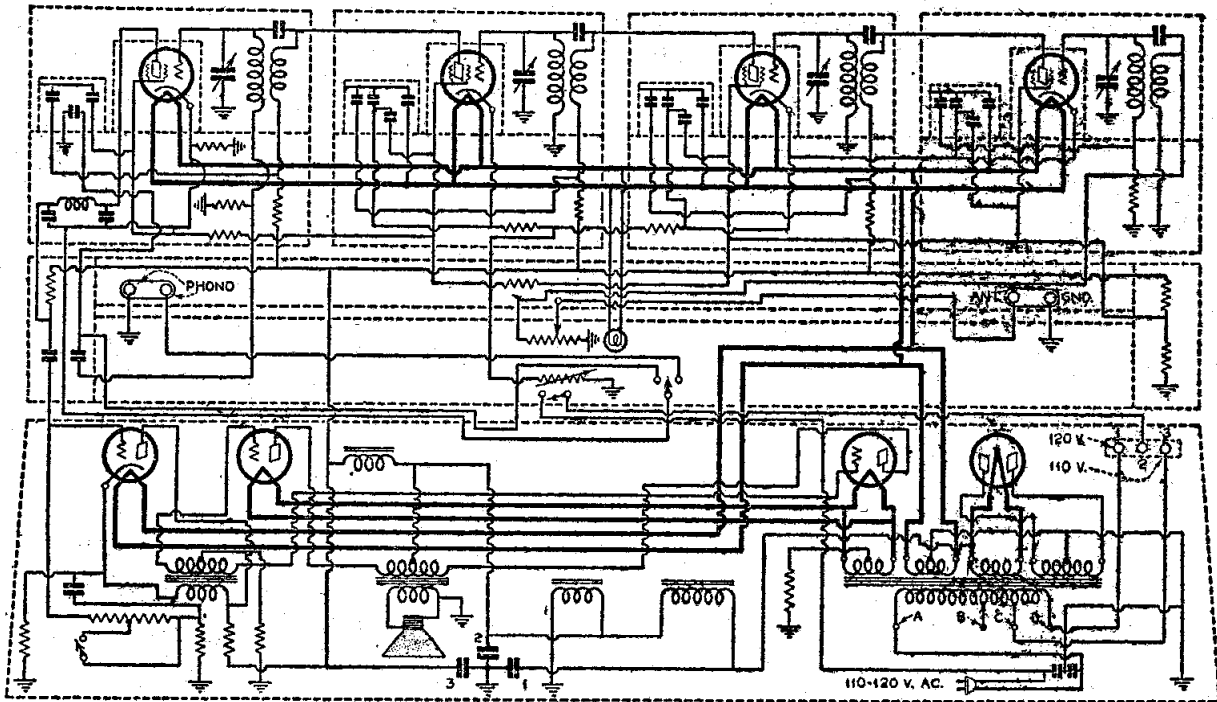

Circuit No. 97
Colonial SG32

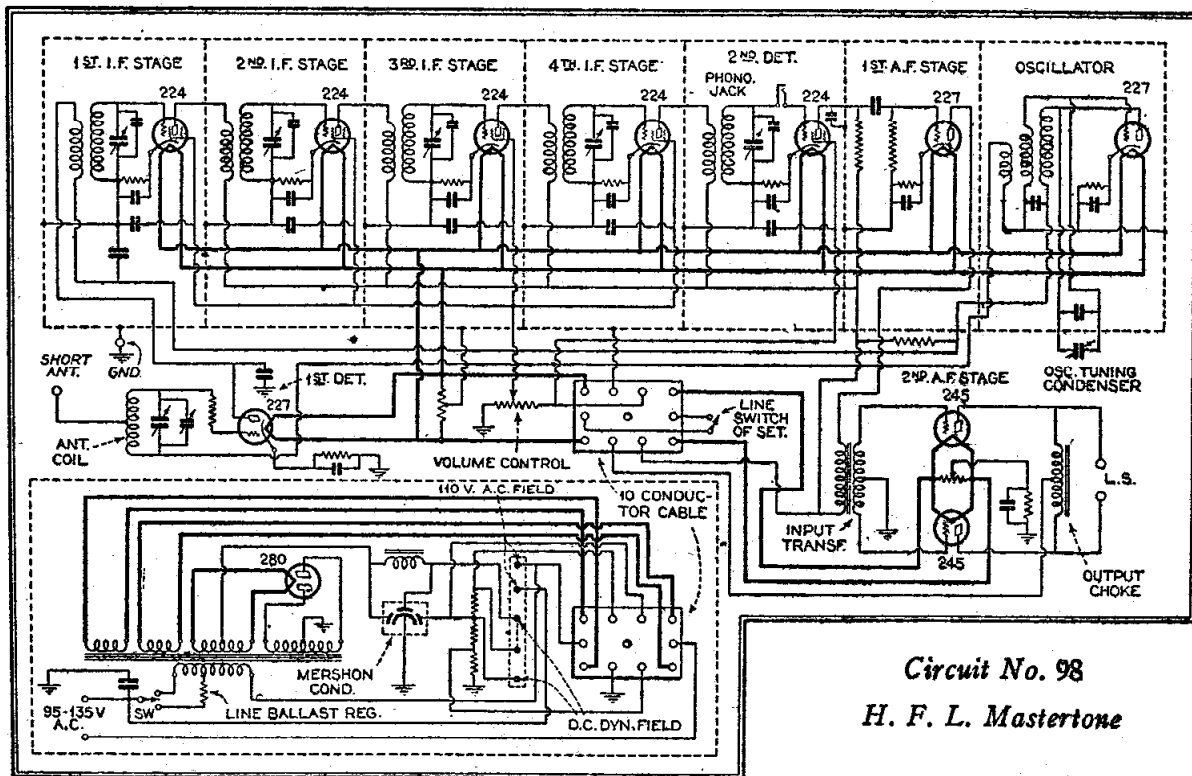

Circuit No. 98
H. F. L. Mastertone

Circuit No. 98 is the diagram of the HFL Mastertone radio receiver including the power supply. Each tube in the intermediate and detector stages is individually shielded as are the individual coils. A pair of -45 tubes are employed in the power audio output stage.

The battery-operated Radiola 16 (circuit No. 99) employs four -01A tubes in the radio frequency amplifiers and detector stage. A -12A tube in the first audio stage and a similar tube in the output stage. One dial control tuning is a feature of this receiver and

is accomplished by using the first r.f. tube as a coupling medium. Volume is controlled by a rheostat in the positive fila-

ment circuit of the radio frequency amplifier tubes.

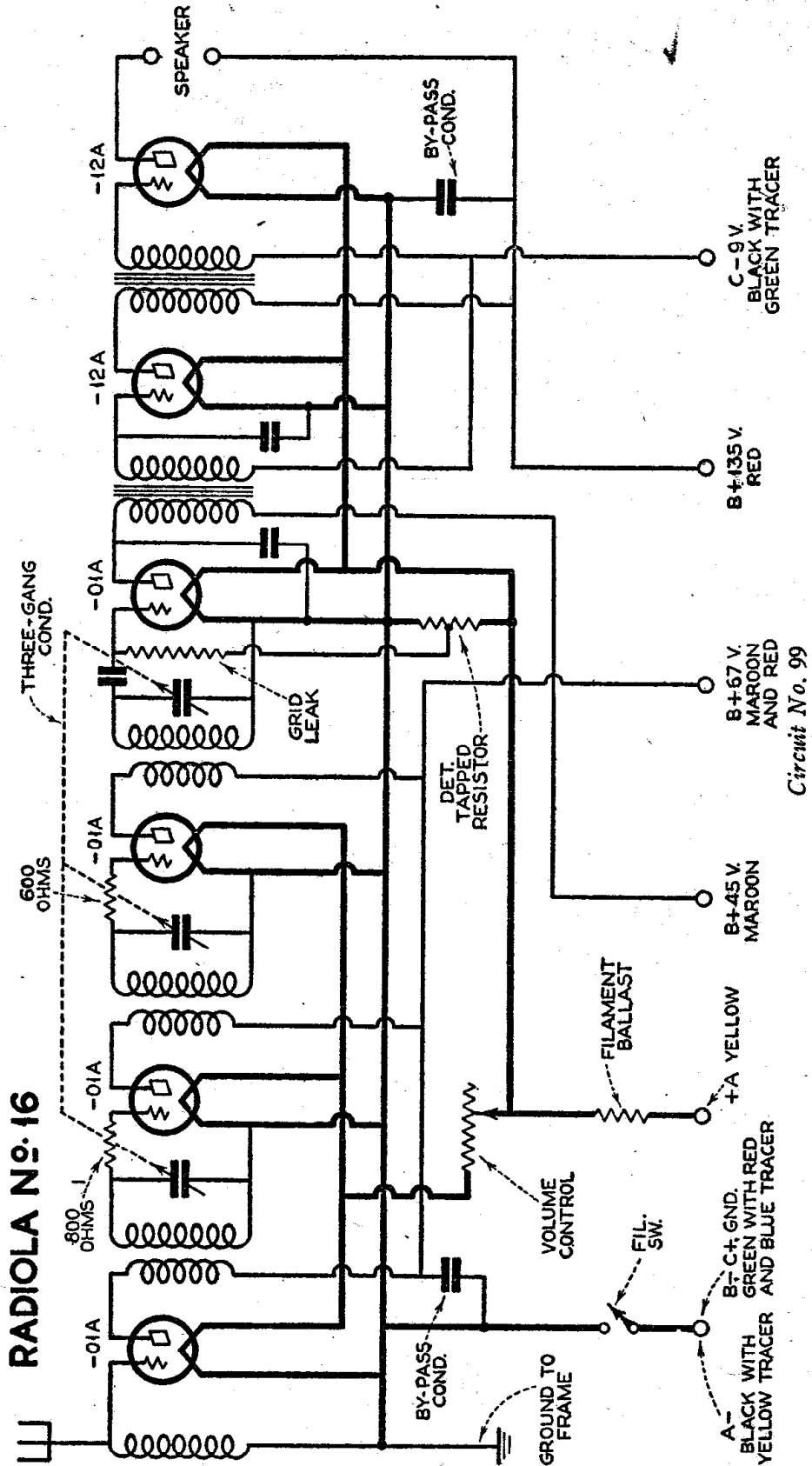

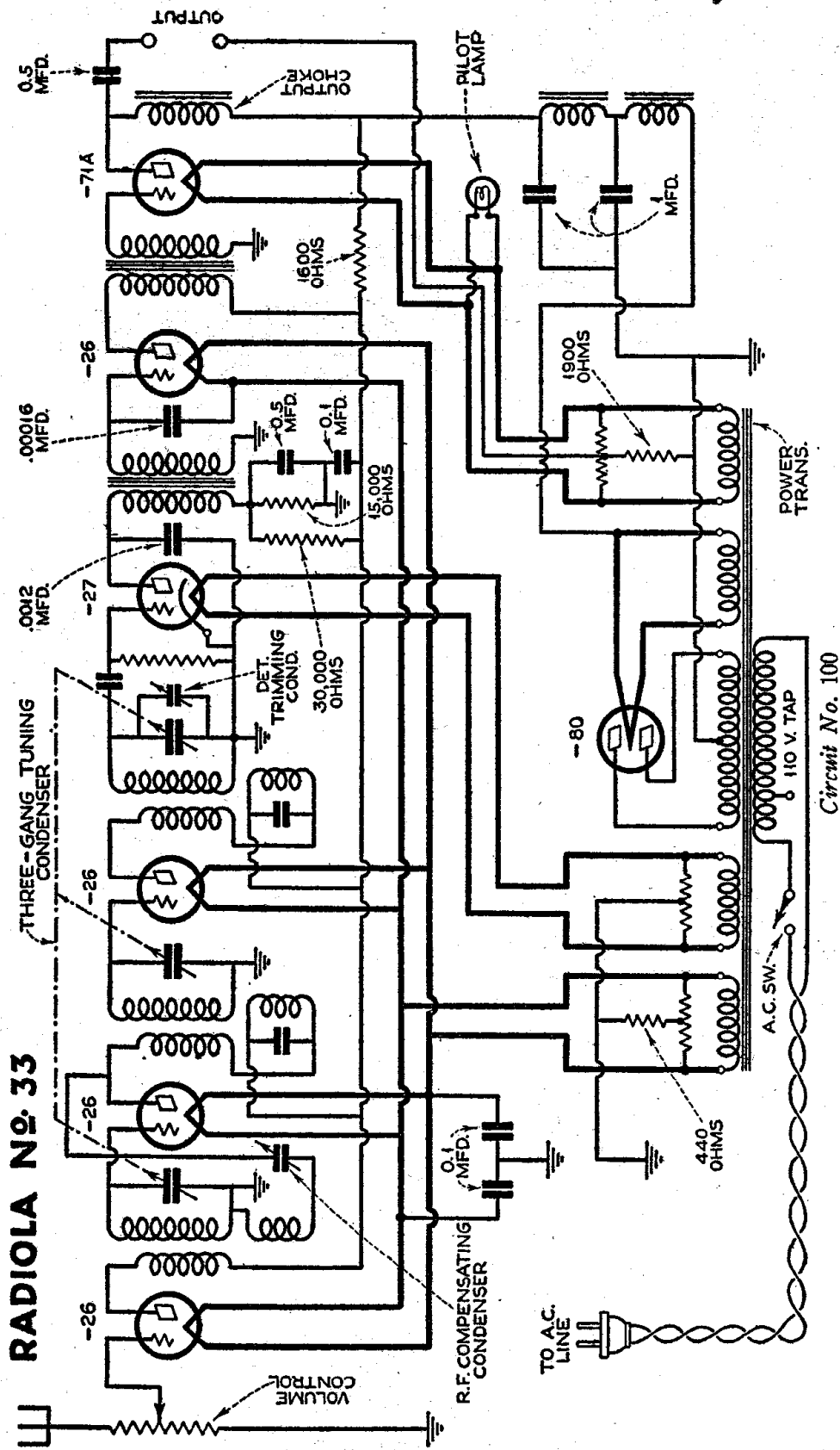

CIRCUIT No. 100 is a schematic diagram of the Radiola No. 33. Here three -26 tubes are employed as radio frequency amplifiers, -27 as a detector, -26 first audio and a -71A as second or output audio amplifying stage. Full-wave rectification is obtained through the use of a -80 tube. This radio receiver is provided with one dial control although provision has been made for compensating on one of the radio frequency stages and a detector stage for extremely fine tuning.

In the Radiola No. 64 Superheterodyne (Circuit No. 101) -27 tubes are employed throughout up to the output stage where a super-power -50 tube is used. Two -81 tubes supply the "B" potential for the

receiver and the field coil of the dynamic speaker.

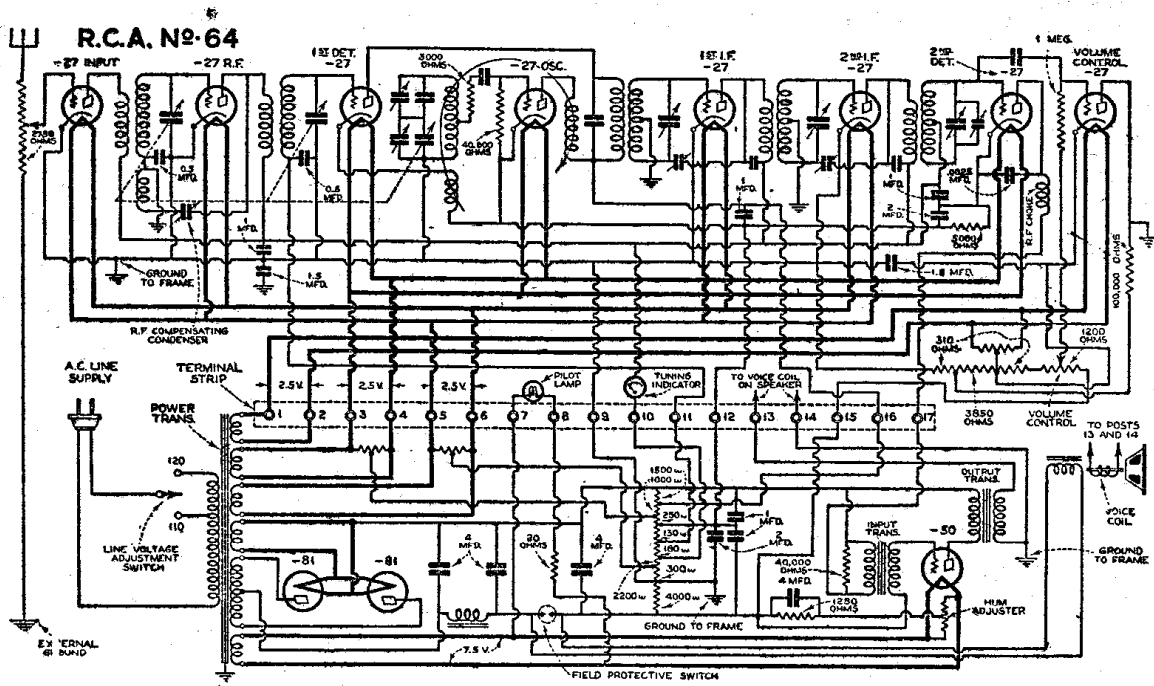

Circuit No. 101

SET BUILDERS and DEALERS

Send for ROYAL-EASTERN'S NEW 124-page 1930 General Wholesale Catalogue

It is free. No obligation to buy

Every worth-while radio, electrical and sporting goods item is featured at lowest wholesale prices. Being the largest Radio and Electrical Mail Order House in the East, we can serve you best. We buy no seconds. We have no job lots. Only fresh and clean products in original factory cartons.

**32 YEARS OF SERVICE TO THE TRADE—THREE BRANCHES—
BEST CREDIT RATING—WE CARRY LARGEST
STOCK IN THE EAST**

Our Banking Affiliations and Depositories
 The National City Bank of New York, N. Y.
 Irving Trust Company, New York
 Brooklyn National Bank, Brooklyn, N. Y.
 Bank of Manhattan, Long Island City, N. Y.
 Huguenot Trust Co., New Rochelle, N. Y.

Royal-Eastern Electrical Supply Company

Send for Catalogue Today. It's free

14-HU West 22nd Street

New York, N. Y.

4 New Radio Books Now Sold at Magazine Prices

**NEW RADIO TROUBLE FINDER
AND SERVICE MANUAL**

**Only
50c**

**1001 RADIO QUESTIONS AND
ANSWERS — 1930 Edition**

RADIO AMATEUR'S HANDBOOK

Each

NEW SHORT WAVE MANUAL

Buy Them at the Newsstands or Mail Order to

MACKINNON-FLY PUBLICATIONS, Inc., 381 Fourth Ave., New York, N. Y.

LET RCA INSTITUTES START YOU ON THE ROAD TO . . . SUCCESS IN RADIO

RADIO needs you . . . That's why the entire Radio industry is calling for trained men. Radio is thrilling work . . . has easy hours, vacations with pay and a chance to see the world. Manufacturers and broadcasting stations are now eagerly seeking trained RCA Institutes men. Millions of sets need servicing . . . thousands of ships require experienced operators . . . Never before was there an opportunity like this.



Radio Mechanic and Inspector
\$1800 to \$4000 a Year.

Broadcast Station Mechanic
\$1800 to \$3800 a Year.



Land Station Operator
\$1800 to \$4000 a Year.

Broadcast Operators
\$1800 to \$4800 a Year



This is the Only Course Sponsored by Radio Corporation of America
RCA sets the standards for the entire Radio industry . . . the RCA Institutes' Home Laboratory Training Course enables you to quickly learn all the secrets of Radio . . . In your spare time you can obtain a thorough, practical education in Radio. You learn Radio by actual experience with the remarkable outlay of apparatus given to every student. That's

why every graduate of RCA Institutes has the experience, the ability and the confidence to hold a big-money Radio job.

Graduates of RCA Institutes Find It Easier to Get Good Jobs

Students of RCA Institutes get first-hand knowledge, get it quickly and get it complete. Success in Radio depends upon training and that's the training you get with RCA Institutes. That's why every graduate of RCA Institutes who desired a position has been able to get one . . . That's why graduates are always in big demand!

Study Radio at the Oldest and Largest Commercial Training Organization in the World

Send for this Free Book . . . or step in at any of our resident schools and see for yourself how thousands of men are already on the road to success in Radio. Remember that you, too, can speed up your earning capacity . . . can earn more money in Radio than you ever earned before. The man who trains today will hold down the big-money Radio job of the future. Come in and get this free book or send for it by mail. Everything you want to know about learning Radio. Each page packed with pictures and descriptions of the brilliant opportunities in this gigantic, world-wide money-making profession.

Send For This Book Today!

For the added convenience of students who prefer a Resident Study Course, RCA Institutes, Inc., has established Resident Schools in the following cities:

New York	75 Varick Street
Boston, Mass.	899 Boylston Street
Philadelphia, Pa.	1211 Chestnut St.
Baltimore, Md.	1215 N. Charles St.
Newark, N. J.	560 Broad Street

Home Study graduates may also attend any one of our resident schools for post-graduate instruction at no extra charge.



Clip this Coupon NOW!

RCA INSTITUTES, INC.

Formerly Radio Institute of America

SPONSORED BY



RCA INSTITUTES, Inc.
Dept. R. H. U., 75 Varick Street
New York, N. Y.

Gentlemen: Please send me your FREE 40-page book which illustrates the brilliant opportunities in Radio and describes your laboratory-method of instruction at home!

Name _____

Address _____

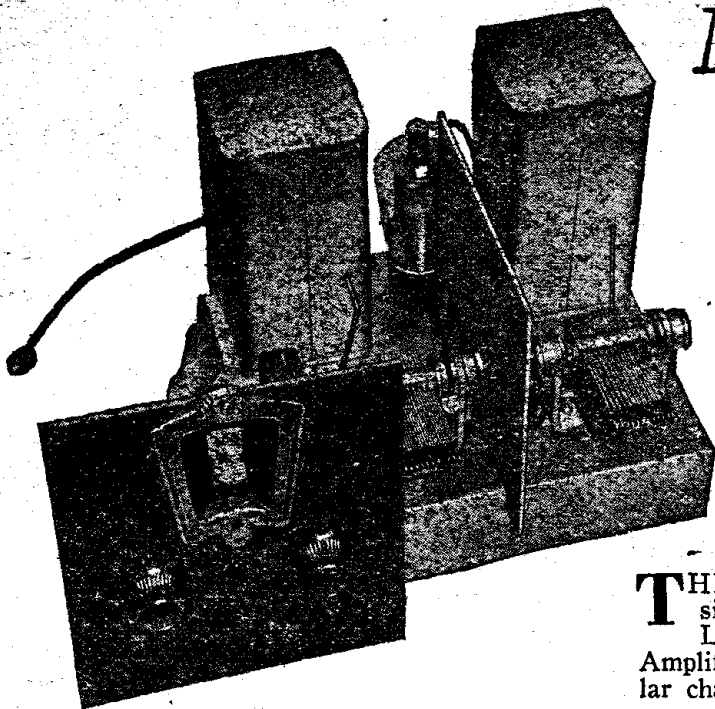

Now a
REAL TUNER

For the **Loftin-White**
AMPLIFIER

By
ELECTRAD

THE Tuner the Radio World is waiting for. Designed specifically for use with **ELECTRAD-LOFTIN-WHITE A-245 Direct Coupled Amplifier**, or any direct-coupled Amplifier with similar characteristics.

IWING to the great public interest in the revolutionary Loftin-White Direct-Coupled Amplifying System, Electrad engineers have developed a carefully matched radio-frequency tuner to work with this type of circuit. Utilizes the power supply of the Electrad A-245 amplifier for A, B and C current, through a convenient plug-in cable. Two tuned stages with — one dial operation — complete shielding with all wiring below metal chassis — simple but efficient volume control — system — unusual ease of assembly are outstanding features.

A product of typical Electrad high quality and most advanced engineering.

Complete parts (except tubes) including assembly and operating instructions. — \$40.00.

**The Famous ELECTRAD
LOFTIN-WHITE A-245
Power Amplifier**

Utilizes one '24, one '45 type tube in the revolutionary Loftin-White Direct-Coupled Amplifier Circuit and gives tremendous volume with unrivalled tone quality.

Self-contained power supply, with 280 Full Wave Rectifier provides all power for amplifier and the New Electrad L-W Tuner described above. Easy to build and operate. Complete Parts (Less tubes)—\$35.00.

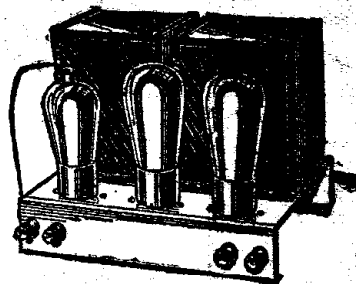

Licensed under Loftin-White Patents Pending for purposes enumerated in our literature only.

Licensed under Patents of Radio Corporation of America and Associated Companies for Radio, Amateur Experimental and Broadcast Reception.

ELECTRAD
INC.

ELECTRAD INC. Dept. 101 RH, 175 Varick St., New York, N. Y.

Please send me immediately full details on your Electrad Loftin-White Tuners and Amplifiers

Name

Address

.....

5,000



Radio Service Men Needed Now!

The replacing of the old battery operated receivers with all-electric Radios has created a tremendous country-wide demand for expert Radio Service Men. Thousands of trained men are needed quick!

30 Days of R.T.A. Home Training

enables you to cash in on this latest opportunity in Radio

\$40 to \$100
a week
Full Time
\$3.00 *an hour*
Spare Time

Ever on the alert for new ways of helping our members make more money out of Radio, the Radio Training Association of America now offers ambitious men an intensified training course in Radio Service Work. By taking this training you can qualify for Radio Service Work in 30 days, earn \$3.00 an hour and up, spare time; prepare yourself for full-time work paying \$40 to \$100 a week.

a week full time, this R.T.A. training offers you the opportunity of a lifetime.

More Positions Open Than There Are Trained Men to Fill Them

If you were qualified for Radio Service Work today, we could place you. We can't begin to fill the requests that pour in from great Radio organizations and dealers. Members wanting full time positions are being placed as soon as they qualify. 5,000 more men are needed *quick!* If you want to get into Radio, earn \$3.00 an hour spare time or \$40 to \$100

Radio Service Work a Quick Route to the Big-Pay Radio Positions

We furnish you with all the equipment you need to become a RADIO Service Man!

Radio Service Work gives you the basic experience you need to qualify for the big \$8,000, \$10,000 to \$25,000 a year Radio positions. Once you get this experience the whole range of rich opportunities in Radio lies open before you. Training in the Association, starting as Radio Service Man, is one of the quickest, most profitable ways of qualifying for rapid advancement. ¶ If you want to get out of small-pay, monotonous work and cash in on Radio quick, investigate this R.T.A. training and the rich money-making opportunities it opens up. No special education or electrical experience necessary. The will to succeed is all you need.

Mail Coupon for No-Cost Training Offer

Cash in on Radio's latest opportunity! Enroll in the Association. For a limited time we will give to the ambitious man a No-Cost Membership which need not . . . should not . . . cost you a cent. But you must act quickly. Filling out coupon can enable you to cash in on Radio within 30 days, lift you out of the small-pay, no-opportunity rut, into a field where phenomenal earnings await the ambitious. You owe it to yourself to investigate. Fill out coupon NOW for details of No-Cost Membership.

The Radio Training Association of America
4513 Ravenswood Ave., Dept. RHU-4 Chicago, Ill.

The Radio Training Association of America
4513 Ravenswood Ave., Dept. RHU-4 Chicago

Gentlemen: Please send me details of your No-Cost training offer by which I can qualify for Radio Service Work within 30 days. This does not obligate me in any way.

Name

Address

City State

Free



MEN!

Get Your Copy of **My New Book**
It shows you
How to get a good job in the Radio Industry

Hundreds of Jobs paying \$50, \$60, \$75, \$100 a week are opening in Radio every year.

I showed these men how to get *Big Pay* like these



Seldom under \$100 a Week

"My earnings in Radio are many times bigger than I ever expected they would be when I enrolled. In November I made \$577, December \$645, January \$465. My earnings seldom fall under \$100 a week. I merely mention this to give you some idea of what a Radio man can do who has the training."

E. E. WINBORNE,
1414 W. 48th St., Norfolk, Va.



\$3000 a Year in Own Business

"I cannot give N. R. I. too much credit for what I have been able to do in Radio. I can safely say that I averaged \$3000 a year for the past three years. I am in the Radio business here. Any man who really wants to advance cannot go wrong in Radio. There is certainly a lack of trained men."

FRED A. NICHOLS,
P. O. Box 207, Eaton, Colo.

J. E. SMITH, Pres.
NATIONAL RADIO INSTITUTE

If you are earning a penny less than \$50 a week, send for my book of information on opportunities in Radio. It is free. Radio's amazing growth is making hundreds of fine jobs every year. My book shows you where these jobs are, what they pay, how I can train you at home in your spare time to be a Radio Expert.

You have many jobs to choose from
Broadcasting stations use engineers, operators, station managers and pay \$1,300 to \$5,000 a year. Manufacturers continually need testers, inspectors, foremen, engineers, service men, buyers for jobs paying up to \$15,000 a year. Shipping companies use hundreds of operators, give them world-wide travel with practically no expense and \$85 to \$200 a month besides. Dealers and jobbers are always on the lookout for good service men, salesmen, buyers, managers and pay \$30 to \$100 a week for good men. Talking Movies pay as much as \$75 to \$200 a week to men with Radio training. There are openings almost everywhere to have a spare time or full time Radio business of your own—to be your own boss. Radio offers many other opportunities. My book tells you about them.

New 8 Outfits give you Extensive Practical Radio Experience

With me you not only get the theory of Radio—you also get practical Radio experience while learning. You can build over 100 circuits—build and experiment with the circuits used in Atwater-Kent, Majestic, Crosley, Eveready, Stewart-Warner, Philco, and many other sets. These experiments include A. C. and screen grid sets, push pull amplification and other late features. When you finish my course you won't need to take "any old job" just to get experience—you will be trained and experienced ready to take your place alongside men who have been in the field for years.

Back view of 5-tube A. C. screen grid tuned Radio frequency set—only one of many circuits you can build with the parts I give without extra charge.



I Will Train You at Home in your Spare Time

Hold your job until you are ready for another. No need to leave home. All I ask is part of your spare time. I have doubled and tripled the salaries of hundreds through my practical home-study training. You don't have to be a high school or college graduate. My course is written in easy, simple terms that most anyone can understand.

My Course Includes Talking Movies, Wired Radio, Television
My course is up-to-date with Radio's latest uses and improvements. It includes Radio's application to Talking Movies, Television and home Television experiments, Wired Radio, Radio's use in Aviation, in addition to fitting you for many other lines.

Money Back If Not Satisfied
I will agree in writing to refund every penny of your tuition if you are not satisfied with my Lesson Texts and Instruction Service when you have finished my course. This agreement is backed by the Pioneer and World's Largest organization devoted entirely to training men and young men by mail, for good jobs in the Radio industry.

Find out what Radio offers you Get My Book

This book gives the facts on Radio's opportunities and the many features and services of N.R.I. training. It gives 100 letters from students who have proved that my methods are successful. Get your copy today. There is no obligation.

J. E. SMITH, President
National Radio Institute, Dept. 0D85
Washington, D. C.

THIS COUPON IS GOOD FOR ONE FREE COPY OF MY NEW BOOK *mail it NOW*

J. E. SMITH, President,
National Radio Institute, Dept. 0D85
Washington, D. C.

DEAR MR. SMITH:—Send me your book. I want to see what Radio offers and what you offer in Radio training. This request does not obligate me in any way.

Name.....
Address.....
City.....State.....

Lifetime Employment Service to all Graduates