

**MODERN RADIO**

**TEST GEAR**

**CONSTRUCTION**



No. 43  
Copyright

# MODERN RADIO. TEST GEAR CONSTRUCTION. CONTENTS.

## Section 1.

**Radio Servicing.**—Ohms Law—Simple Tests—D.C. Voltmeters, Ammeters—A.V.C.—General Testing of Superhet receivers, etc., etc.

## Section 2.

**Measuring Instruments.**—Moving coil—Thermal—Moving Iron—Electro-static meters—Voltmeters—Ammeters—Ohmmeters, etc.—Meter construction and methods of use.

## Section 3.

**Valve Voltmeters.**—Construction—Methods of operation—Circuit analysis, etc., etc.

## Section 4.

**Signal Generators.** — Design — Calibration — Methods of use—Trimming Superhets, etc., etc.

## Section 5.

**Multivibrators.**—Action of—Fundamental frequencies—Harmonics—Use with Superhets, etc., etc.

## Section 6.

**Audio Oscillators.**—Construction of—Methods of use—Speaker tests—Phase shift and modulation tests, etc., etc.

## Section 7.

**Output Meters.**—Design—Voltage or current measurements, calibration, etc., etc.

## Section 8.

**Valve Tests.**—Continuity—Mutual conductance—Amplification—Anode resistance, etc., etc.

## Section 9.

**Component Testing.** — Wheatstone's Bridge — Owen's Inductance Bridge—Simple Condenser Bridges, etc., etc.

*Acknowledgment is given for the fact that the circuit of the Beat Frequency Audio Generator shown in Fig. 12, Section 6, has been adapted from the original of C. P. Edwards and Messrs. Cooper and Page.*

*The circuit of the Electrolytic Condenser Test Set, Section 9, Fig. 19, is reproduced by courtesy of J. H. Reyner, Esq. ("Testing Radio Sets") and Messrs. Chapman and Hall.*

*The Ammeter-movement shown on the cover is reproduced by courtesy of Messrs. Taylor Electrical Instruments Ltd.*

Copyright by BERNARDS (PUBLISHERS) LTD., The Grampians, Western Gate, London, W. 6.

**SECTION 1.**  
**RADIO SERVICING.**

The first key to the solution of all problems in Radio Servicing is Ohm's Law:—

$$I = \frac{V}{R}, \quad V = I \times R, \quad R = \frac{V}{I}$$

(V = volts, I = current in amperes and R = resistance in ohms), for by the intelligent application of one or other of these statements any electrical circuit can be checked with the minimum of trouble and dismantling, and its operating characteristics determined.

For the average radio receiver the testing apparatus required can be as little as a good D.C. voltmeter, one having a high resistance and capable of reading to 250 and 500 volts in two ranges, giving accurate indications on a clearly calibrated scale. Any instrument acquired over and above the D.C. voltmeter will, of course, make the work proportionately simpler. A milliammeter and resistance meter, together with an A.C. voltmeter, make a sound basis for good work and often all these instruments, together with the D.C. voltmeter are combined, all the readings being given on one scale. Such an instrument is known as a circuit analyser, and circuits are shown in Section 2.

Testing with an analyser should always be carried out by logical steps and in a methodical manner.

Fig 1 shows the basic circuit of a modern superhet, and will be used as an example.

In the case of a set which fails altogether to give signals the tests must obviously begin with the power supply. The full D.C. voltage should appear across points "A—B", and should the meter give no indication here, the powerpack being disconnected from the receiver, the supply circuit obviously needs investigation.

Any breakdown in the smoothing condenser "C" will quickly show itself in overheating of the loudspeaker field winding and possibly sparking and burning in the condenser itself, while if the reservoir condenser "D" has broken down it is very likely that the rectifier valve and even the transformer will be ruined. These condensers must be of adequate working voltage, and be connected with their polarities correct.

Should these condensers become disconnected, either internally or in their external wiring, there will be a drop in voltage across "A—B" if the fault lies in "D" while the receiver will hum loudly if "C" is at fault.

Heating or burning-out of the transformer may also be caused by a wiring short-circuit or shorting turns in either the primary or secondaries. Shorting turns are apparent by reason of the voltage drop across the secondary winding concerned, or by an overall secondary voltage drop should the shorting turns be in the primary.

A broken or open-circuit primary, of course, will put all secondaries out of action on a voltage check.

Care should be taken when testing high tension windings as peak voltages in quite a small transformer can be dangerous.

A burnt out rectifier valve may be due to age alone, or it may be due to shorting in the wiring, condensers or by a transformer breakdown between the high tension and rectifier heater windings. It should be remembered that short circuits can occur in the receiver wiring as well as in the power pack.

All transformer windings should have infinite resistance to each other and to earth (i.e., the transformer frame and core), and should there be any leakage the transformer is unsafe and needs rewinding.

Tests on the L.F. choke or loudspeaker field are simple—a continuity test if the winding fails to pass current or if it becomes overheated and shorting turns are suspected, a test for resistance

$$\text{using } R = \frac{V}{I}$$

It must be remembered that I refers to the current in amperes and as in radio practice milliamperes are more generally met with the current must be expressed as a decimal or fraction. Thus for

Ohm's Law a current of 10 milliamps is shown by .01 or  $\frac{10}{1000}$ .

To test the winding pass a known current through it—20 milliamps for example—and with a high resistance D.C. voltmeter measure the volts dropped across the coil—for example 20 volt

$$\text{Then } R = \frac{V}{I} \text{ or } \frac{20}{\frac{20}{1000}} = \frac{20 \times 1000}{20} \text{ ohms, which is 1,000 ohms.}$$

Fig. 1

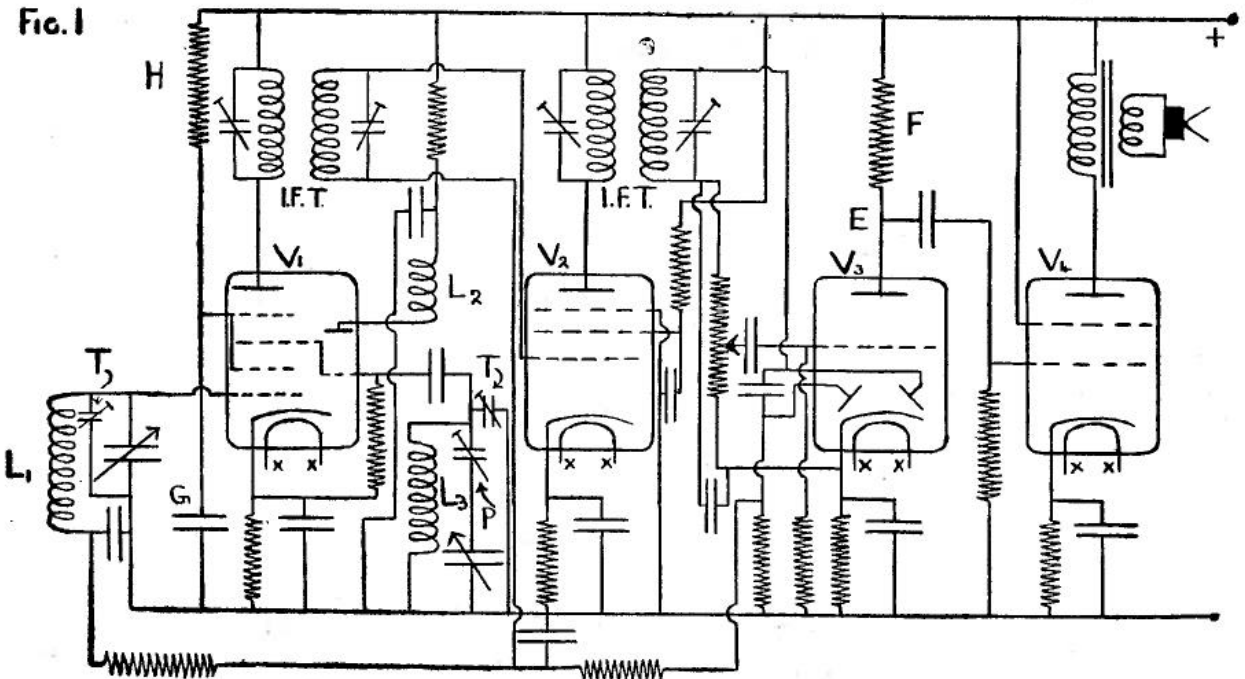

BASIC CIRCUIT OF MODERN SUPERHET

SECTION I

This effect of the analyser's own current will often cause small errors. At point "E" for example, 200 volts might be expected, between "E" and Earth, the anode resistor being perhaps 50,000 ohms. The analyser, however, supposing it to require .5 milliamp for its operation, would show only 175 volts. The .5 milliamp flows through "E" with the valve current, causing an extra drop of

$$V = I \times R \text{ or } \frac{.5}{1,000} \times 50,000 \text{ volts or } 25 \text{ volts. It is for this}$$

reason that a high resistance voltmeter is so often specified, such an instrument having greater sensitivity, lower current consumption and therefore causing less error on measurements. 1,000 ohms per volt is a good figure.

Faults often occur in electrolytic condensers and the biasing condensers can cause trouble by becoming internally disconnected or by shorting across the biasing resistor. A disconnected biasing condenser will cause the anode frequencies to flow through the resistor, thus causing a fluctuating voltage drop which will impose negative current feedback on the valve in question, giving a drop in volume and probably distortion. A short circuited resistor will allow the grid to operate without biasing so that the valve will at least distort and probably run into grid current, overheating the electrodes and damaging the emission. The overloading and choked distortion, however, should be simple to trace.

V3 may be checked on the audio side by the same methods as the output stage with special attention to the coupling condenser from its anode to the output valve's grid. If this condenser leaks to any degree the entire biasing of the output stage will be upset. To avoid damage to valves, coupling condensers must be chosen having good insulation.

The diodes of V3 are handling both the high and audio frequencies but the circuit is straightforward and the most likely source of trouble is the I.F.T., where shorting turns or internal disconnection may cause an entire absence of signals. The volume control and fixed resistors and condensers may also give trouble.

If the A.V.C. line is put out of action by a broken circuit, a variety of faults in the stages of V1 and V2 may cause overloading, distortion, poor selectivity, motor-boating or signals may disappear, depending on the type of circuit. In this case as in most others the makers' service sheets are of great value if they can be obtained.

In the circuit of V2 the I.F.T. may also give rise to faults while the biasing of H.F. stages is as important as on the output side. An internal break in the biasing condenser wiring will cause

signals to lose strength and possibly vanish while distortion and overloading will occur if the resistor is shorted.

In all these cases a measurement of anode and screen voltages will always prove of value and this is especially so in the case of V1 for the operation of the oscillator may easily be checked by including a milliammeter in the triode anode circuit (or measuring the voltage drop across the feed resistor). If the grid coil is then shorted with a length of wire a change in the current or voltage reading indicates that the oscillator is working correctly. The readings may either drop or rise, depending on the circuit employed.

Should there be no oscillation there may be shorting turns on the coils, a disconnected coil or anode condenser, a broken feed circuit or low emission in the valve—a misleading fault but not unusual.

The hexode portion of V1 should be tested as already described. It will be seen that the tuned circuit is completed through a bias blocking condenser and should this be disconnected signals will cease as they will also in the case of a broken coil winding or the coil having turns shorting down to earth.

The screen voltage should be checked as carefully as the anode voltage, on V1 as on all pentodes, for if the condenser "G" should develop an internal short circuit the screen would be reduced to earth potential. Signals would vanish and a voltage check on the screen feeding resistor "H" would show the full high tension voltage across it.

It will be seen then that voltage and current checks are of paramount importance, enabling a fault to be localised. No matter how stubborn the trouble a faulty receiver must be investigated in this logical sequence of tests, and no stage from power pack to aerial should be passed or disregarded until its correct operation is assured. In the sections which follow details are given of the means of constructing apparatus to perform this testing. The trimming of aerial circuits and the adjustment of oscillator and I.F. stages are included under Sec. 4, "Signal Generator."

## SECTION 2.

### MEASURING INSTRUMENTS.

Meters, of more properly, measuring instruments, may be of many varieties and types but for radio work only four classes need be considered. By far the most important are

#### 1. Moving Coil Instruments.

those in which the pointer is attached to a coil of wire wound on a light aluminium frame, the movement of which in the magnetic field

assists the damping. The coil assembly is mounted by pivots riding in jewels so that it rotates about a cylindrical iron core, the whole being between the poles of a powerful permanent magnet. The current is fed to the coil by means of light springs (which also control the movement of the pointer and return it to zero when no current is flowing) so that when the coil is connected to a circuit it develops a magnetic field by reason of the current flow, the strength of the field determined by the strength of the current. This field interacts with that of the magnet, causing the coil and pointer to move until the forces are at equilibrium.

Obviously A.C. cannot directly be measured with such a device, but a small rectifier can be included with the instrument.

Such instruments are very accurate, sturdy and adaptable to a remarkable degree. A 1 milliamp meter, or better, a .5 milliamp meter, with as high an internal resistance as possible for ease in shunting, is capable of reading milliamps, amperes and volts in D.C. and A.C. It must be noted, however, that the Universal Analyser of Fig. 4 does not include A.C. To measure A.C. an instrument transformer must be used, designed for the apparatus in hand and details of such transformers are far beyond the scope of this book.

A.C. is conveniently measured, however, by

## 2. Thermal Instruments.

The Hot Wire Ammeter is now superseded by the Thermo-electric Ammeter. A moving coil milliammeter is matched to a thermo-couple, a device which generates D.C. on the application of heat, and this couple is welded to a small heater wire through which the A.C. flows. The instrument is calibrated in R.M.S. values and the calibration holds good for a range of frequencies extending from the audio to the radio bands. The heater wire has a resistance of generally well under an ohm, so that little power is lost in the instrument.

The one disadvantage of the system is the ease with which the heater is overloaded or burnt-out, and the writer advises that if such an instrument is obtained it be mounted on a panel and have across its terminals a low resistance shunt—say .05 to .1 ohm—controlled by a switch so that with the shunt in circuit the meter range is multiplied by five or ten times. The meter may then be connected up and inspected for overloading before the switch is opened, rendering the shunt inoperative.

## 3. The Moving Iron Instrument

is of little use for radio measurements. It needs a good deal of power for its operation and is liable to lose calibration accuracy

at over 300–500 cycles. It works on the principle of magnetic repulsion—a fixed and moving vane are situated in a coil of wire through which the current flows so that whether A.C. or D.C. is used both vanes have the same magnetic polarity at any one instant. The degree of magnetisation depends on the current, and causes the moving vane to swing, with the pointer, away from the fixed vane.

## 4. The Electro-static Voltmeter

consumes no power on D.C. readings and extremely little on A.C. and is capable of accurate calibration up to several thousands of cycles. It is constructed in the form of a very light condenser, a moving vane riding between fixed vanes and attracted into position by the difference of potential across them. Its limitation lies in being of little use except for high voltage work, so that it is chiefly of value in television practice where currents are small and consequently the errors caused by meter current may be serious.

It will be seen, therefore, that of all types of instrument the moving coil is the most adaptable, and it is merely necessary to mount the instrument in a circuit which will deliver to it a suitable proportion of the whole current for it to measure widely differing ranges of volts and current. Due to the linearity of resistance effects the various proportions chosen will all bear correct relationships to the original currents and thus give accurate readings on the original scale calibrations.

To measure voltage it is necessary to add resistance in series with the meter. Suppose it to be a 1 milliamp meter, then to convert the full scale reading to one of 100 volts resistors must be added which will allow 1 milliamp to flow with 100 volts across the chain.

$$R = \frac{V}{I} = \frac{100}{\frac{1}{1000}} = 100,000 \text{ ohms.}$$

Therefore, if 100,000 ohms be connected in series with a 1 milliamp meter, it will read 100 volts full scale deflection. Similarly 1,000,000 ohms will enable it to read 1,000 volts.

It is useful to remember that for 1 milliamp a resistance of 1,000 ohms drops 1 volt.

For series working it must be remembered that the meter resistance is included in the chain. For a meter of 200 ohms resistance and 1 milliamp sensitivity this would account for 1 per cent. at 20,000 ohms, or at 20 volts. However, the general type of instrument, even of good make, rarely has an accuracy of more than 1 per cent., so that over this value the meter resistance may safely be disregarded.

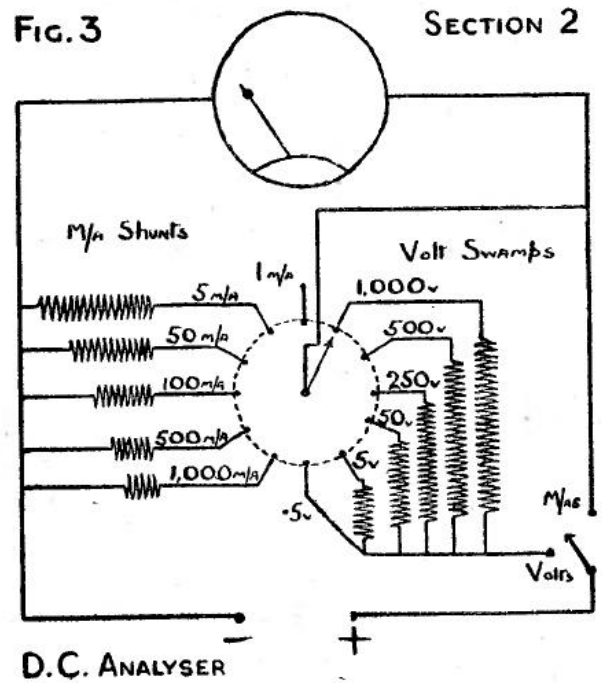
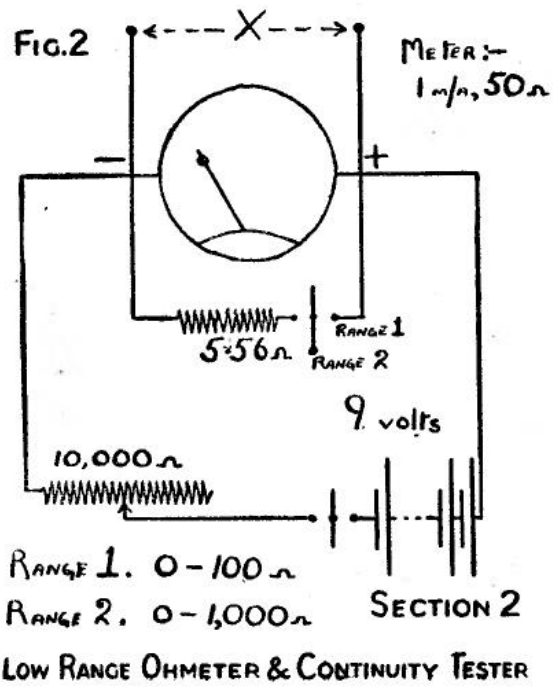

For measuring D.C. the meter must have a low resistance across its terminals, in parallel, so that most of the current will flow through the "shunt" and only a small portion through the moving coil. The proportion is given by

$$X = \frac{R + S}{S}$$

where X is the factor by which the range is multiplied, R is the resistance of the meter and S is the resistance of the shunt. For example, the 1 milliamp, 200 ohm meter mentioned above is required to read 100 milliamps full scale.

$$\text{Therefore } X = 100, R = 200 \text{ ohms and } 100 = \frac{200 + S}{S}$$

$$\text{Therefore } 100S - S = 200 \text{ and } S = \frac{200}{99} \text{ or } 2.0202 \text{ ohms.}$$

Once again, however, 2.0002 may be read as 2 ohms, for .002 means only an error of 2 per cent, while it has been seen that the instrument itself is probably no more correct than to plus or minus 1 per cent.

The shunts must be made with wire which will carry the current without heating, which would give rise to thermo-electric effects, and they must be obtained as precision resistors or calibrated on a good bridge (Sec. 9). If calibrated shunts are unobtainable, however, an instrument can still be shunted by experimental means. For example, if it is desired to make a 1 milliamp meter read to 10 milliamps, connect it in a circuit which will pass the 1 milliamp and give a full scale deflection, then with the current still flowing connect a length of resistance wire across the meter terminals. Obviously the reading will fall, and the wire may be adjusted in length until the reading is on tenth (.1 milliamp) of its original value. This means that the shunted wire is giving the meter a multiplying factor of 10, and the wire, cut to this length and properly connected, is a 10 milliamp shunt. The accuracy of this method depends on the clarity and correct calibration of the scale, however, and it is plain that high factors cannot be obtained with a guarantee of high accuracy.

For series resistances carbon resistors are useless unless of the "cracked" 1 per cent. accurate type and precision wire wound resistors should be obtained or made.

Instrument rectifiers vary, and whilst that shown in Fig 4 is the Westinghouse 1 milliamp instrument type no figures are given for its series resistors or "swamps." A high resistance meter such

as that shown will have a linear A.C. scale, so that individual analysers are easily calibrated for A.C. volts.

For the 10 volt A.C. range connect in the circuit a 20,000 ohm wire wound resistor and switch onto a known A.C. voltage—for example 4 volts from a good valve heater transformer. Then by removing turns from the resistor the pointer reading can be brought up to the correct point for 4 volts on the scale, and the range will be calibrated. For the 1,000 volt A.C. range a good reference point is given by the 230 volts mains (or district voltage). In this case 2 megohms are connected in circuit, 1.5 megohms of which may be a carbon resistor, fixed, and .5 megohms an adjustable wire resistor as before. Once again resistance is removed until the pointer indicates the correct reading for 230 volts on the 1,000 volt scale, when the whole range will be correct.

For high voltage ranges switch off before making adjustments

A table of resistances for the instruments of Figs. 3 and 4 follows.

These resistors are correct only for the instruments shown. Different meters will need different resistors, worked out as already described.

TABLE.  
FIGURE NO. 3.

Volts.	Series ohms.	Milliamps.	Shunt ohms
.5	—	1	—
5	4,500	5	125
50	50,000	50	10.2
250	250,000	100	5
500	500,000	500	1
1,000	1,000,000	1,000	.5

FIGURE NO. 4 (D.C. only).

Volts.	Series ohms	Milliamps.	Shunt ohms
.25	—	.5	—
5	9,500	5	55.56
25	49,500	50	5
250	500,000	100	2.5
500	1,000,000	500	.5
1,000	2,000,000	1,000	.25



- RANGE Switch:-
1. M/ps & Ohms
  2. D.C. Volts
  3. A.C. Volts

FIG. 4

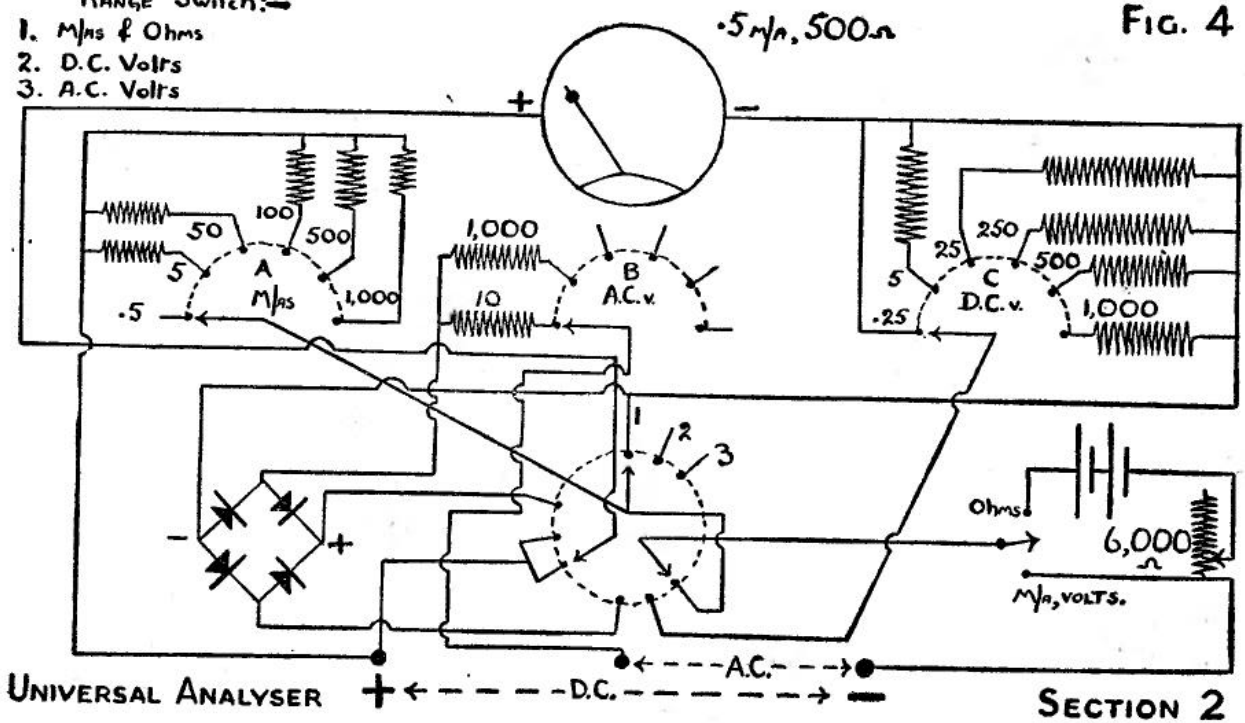

The rheostat in Fig. 4 of 6,000 ohms should be wirewound. Switches in all circuits should be of the rotary Yaxley type, except where on-off switching only is required. This should be performed by Q.M.B. tumbler switches. As already noted the rectifier is the Westinghouse 1m/A type.

#### OHMMETERS

The ohmmeter of Fig. 2 is for low resistances and measures their shunting effect across the instrument. Before each reading is taken the instrument should be set to top mark (infinity) by setting the rheostat to give the full scale reading. Connecting the unknown resistance across the "X" terminals will cause the reading to fall.

The unknown resistance is given by

$$X = \frac{R_m \times I_2}{I_1 - I_2}$$

where X is the unknown resistance,  $R_m$  is the resistance of the moving coil instrument,  $I_1$  is the full scale current reading and  $I_2$  is the new current reading.

The range switch gives a multiplying factor of 10.

The ohmmeter included in Fig. 4 is merely a means of measuring resistance by measuring a current passed through it. The range switches are set to "ohms", and the "plus" and "minus" terminals short-circuited by a wire, the rheostat being adjusted to give a full scale reading on the meter. The shorting link is then removed and the unknown resistance connected in its place, the meter giving a new reading. The resistance is given by

$$X = \frac{R \times I_1}{I_2} - R$$

where X is the unknown resistance,  $I_1$  is the full scale current and  $I_2$  the new current reading

R is the internal resistance of meter, rheostat and battery, and may easily be found. For a 3 volt battery and a .5 milliamp meter it would obviously be 6,000 ohms; for a 4.5 volt battery on the same instrument it would be 9,000 ohms.

The accuracy of the ohmmeter depends on the correct battery voltage being known, so that it may be applied to this calculation for R

Ranges of "X" are multiplied by switching in the milliamp shunts, the greater the current the lower the value of "X" which

can be read. For example, using a 3 volt battery and the 50 milliamp range R would be  $\frac{3 \times 1,000}{50}$  which is 60 ohms and a reading  $I_2$  of 30 milliamps would indicate

$$X = \frac{60 \times 50}{30} = 60 \text{ or } 40 \text{ ohms.}$$

A graph may be drawn relating resistance to scale readings using the 500 milliamp range, then multiplying factors of 10 would correspond to 50 m/A shunt, of 100 to the 5 m/A shunt, and 1,000 to the .5 m/A range, all values thus being taken from one chart.

### SECTION 3.

#### VALVE VOLTMETERS.

The circuits of Figs. 5, 6 and 7 are no more than an introduction to the subject of Valve Voltmeters, and should it be desired to make much use of such instruments they should be studied in greater detail.

In brief, the Valve Voltmeter is an instrument designed to measure practically any frequency of A.C. or oscillating voltage, the valve acting as an almost constant characteristic rectifier of high impedance. To retain this high impedance which is so necessary for this type of work the instrument in Fig. 5, which is of a direct reading circuit, must be as sensitive as possible, and a 50 micro-ampere moving coil galvanometer is very suitable. Series resistors are switched into the leads to the valve which is coupled as a diode, and such resistors should be non-inductive. If an A.C. analyser is available it is best to calibrate the instrument to the ranges desired with resistors to suit individual working conditions on 50 cycle (A.C. mains) current, but if this cannot be done a specimen table of resistors follows.

These values were determined at 50 cycles using an HR210 (not new) with a full 2 volts on the filament, but no guarantee of accuracy can be given as it was found that changes of valve and even quite small changes of filament voltage gave different readings.

Volts.	Series ohms.
15	
5	21,650
15	89,250
50	285,000
100	1,250,000
250	2,820,000

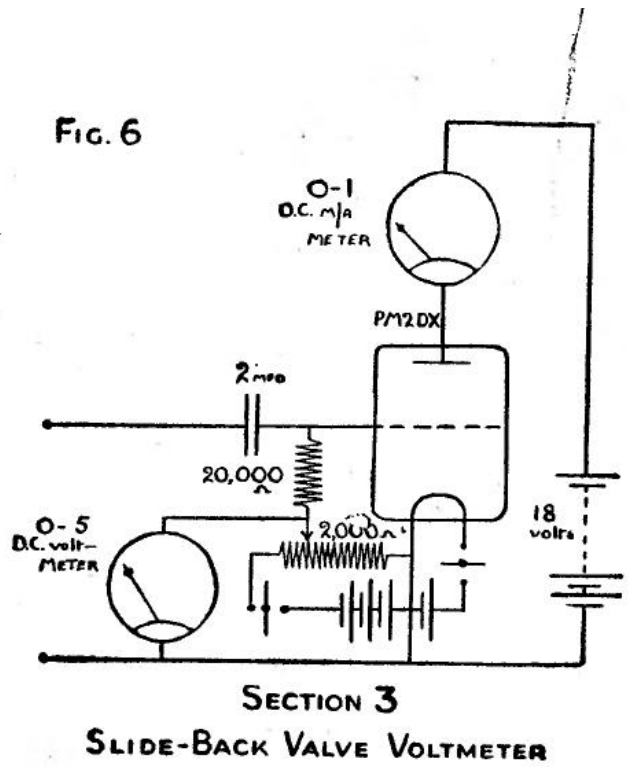
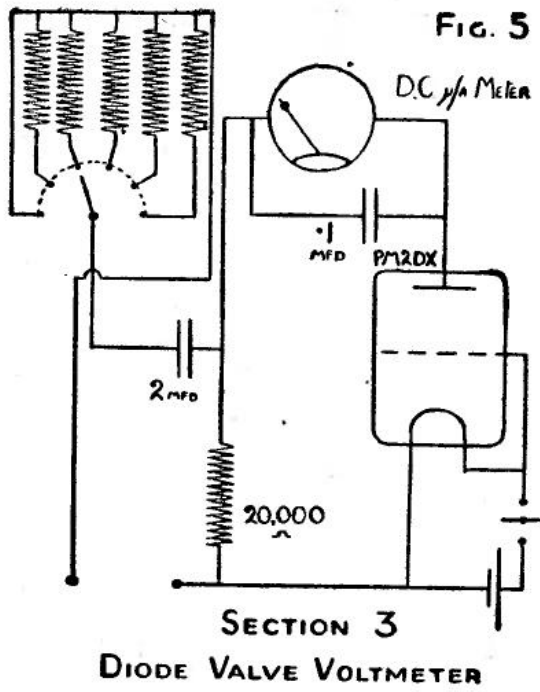
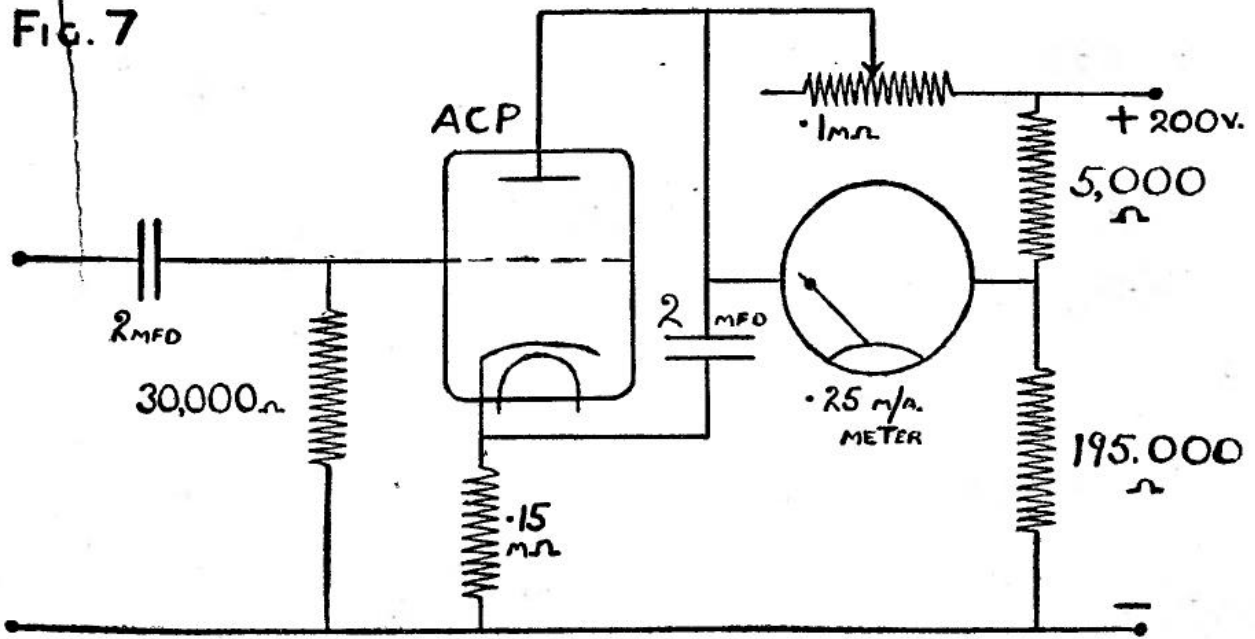

FIG. 7



REFLEX VALVE VOLTMETER

SECTION 3

It is advised, therefore, that individual calibration be adopted where possible. A direct reading voltmeter of this type has a tendency to indicate peak A.C. values of the volts, although the instrument may be calibrated for R.M.S. as the above resistors were. This means, however, that where the input waveform is not of a pure sinusoidal type, such as an audio voltage, the calibration will not be maintained accurately.

It may be noted that Peak volts are equal to the R.M.S. volts multiplied by 1.414 or that R.M.S. equals the peak voltage multiplied by .707 for sine waves only.

Fig. 6 is of a "Slide-Back" Valve voltmeter, a particularly useful instrument where readings of 5 or 10 volts are required, although its range may be extended by including suitable batteries and voltmeters

The valve has a variable biasing circuit coupled to the grid and before the external potential is applied the bias is adjusted by means of the potentiometer until the anode current is as low as possible, but not so low that variations caused by a further change in bias are not immediately noticeable.

The readings of the grid voltmeter and anode milliammeter are then taken, and the external voltage applied to the feed-in terminals. The anode current will rise, due to partial neutralisation of the bias, and the milliammeter is brought back to its first reading by a further adjustment of the potentiometer to increase the amount of bias. Clearly the difference of voltages required to "slide back" the anode current to its original figure is the value of the peak A.C. volts applied or

$$\text{Peak A.C. volts applied} = V_2 - V_1$$

The circuit of Fig. 7 is of the anode bend detector or "Reflex" type, and reads average voltage values. The range covered depends on the combinations of anode voltages and biasing resistors used, and as the anode milliammeter has to be calibrated in terms of the A.C. applied to the feed-in terminals (either directly or by graph), the instrument is not so convenient as the previously mentioned types. To use the instrument it is merely necessary to adjust the rheostat so that the meter gives a zero reading without A.C. applied.

Calibration may be carried out against the A.C. ranges of an analyser, however, using A.C. mains and transformers or resistors as the source of supply, or a known A.C. voltage may be applied to the ends of a long straight resistance wire.

For example, 6 volts from a heater transformer applied to 30 inches of resistance wire will give a voltage fall of 1 volt for each 5 inches of wire, regardless of the current flowing, this being a valuable method of obtaining known voltages on either A.C. or D.C.

The wire should preferably be stretched along a plank over a yard or metre measure, then by connecting one lead to one end of the wire and tapping off with a second lead at any point, voltages may be read in the form of inches or centimetres.

Valve voltmeters may be used to measure audio output (Sec. 7), the output of signal generators, the signals as delivered to the diode of a superhet, R.F. induced voltages in coils, etc., or be used in various forms of bridges (Sec. 9).

#### SECTION 4.

##### SIGNAL GENERATORS.

For testing the radio frequency stages of either a straight-tuned or superhet receiver it is plainly desirable to inspect them under working conditions—that is, when they are receiving a signal. A broadcast programme, however, is hardly suitable. The modulation or sound content is always varying so that an output meter will give no valuable reading, the strength of the wave received cannot be varied and its frequency is fixed. What is wanted is a local oscillator with modulation of constant depth to be switched in or out as desired and a wide range of continuously variable and calibrated frequencies.

Such instruments—Signal Generators—can be of highly elaborate design, but the circuits of Figs. 8 and 9 embrace the necessary points and are easy to operate. They both illustrate a radio frequency oscillator modulated with audio frequency, Fig. 8 being a dynatron oscillator for battery working and Fig. 9 a triode feedback type.

In both cases construction must be carefully carried out for the frequency ranges, once set, must be subject to no changes caused by vibration, or stretching or bending of wires and components. At 300 metres an error of 1 per cent. amounts to 10 kcs., an appreciable discrepancy.

As the whole apparatus must be mounted in a metal box to give complete screening there will be temperature rises and corresponding drifts but as the signal generator is used for short periods only this source of error will not be of great importance, or else the generator may be switched on a half hour before use.

FIG. 8

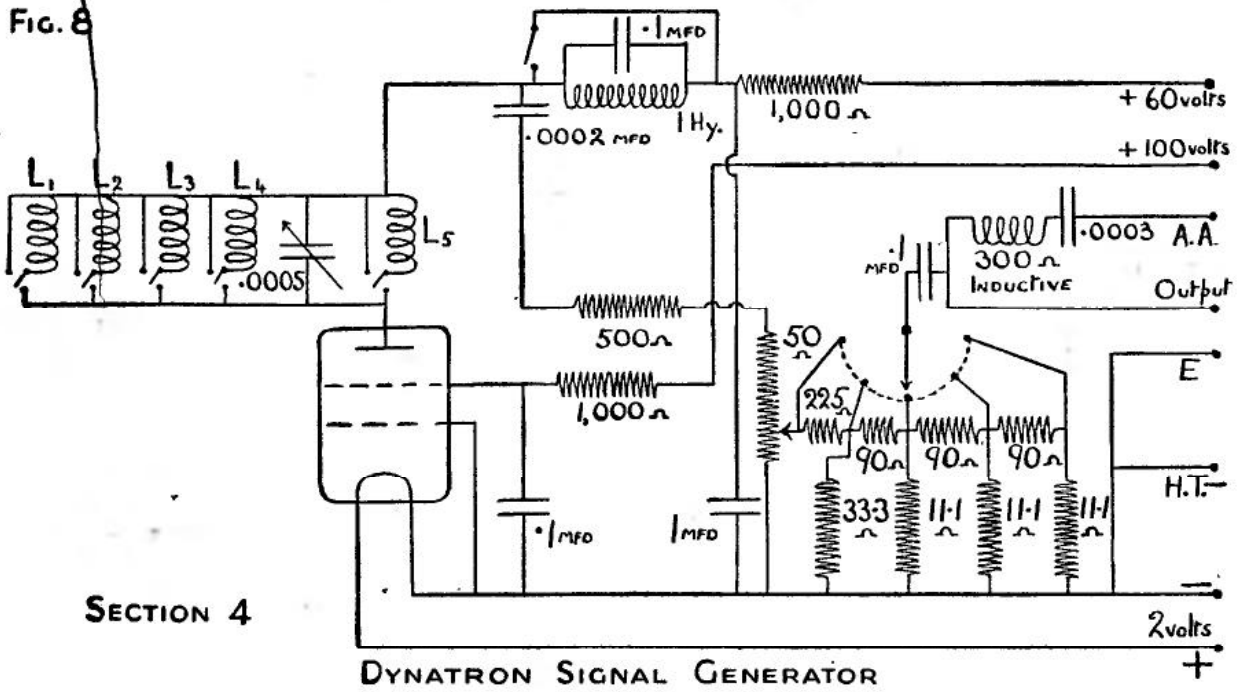

Components must be good, coils especially being rigidly made and mounted. A table of coil data is given, but the constructor is strongly advised to obtain commercial coils made under the correct conditions, with guaranteed range coverances. The Wearite "P" type coils are very suitable, being strong and of small dimensions, thus enabling the inductances to be assembled neatly round the range switch. Coils not in use should be short-circuited while the switch should be of the Yaxley type with a shorting ring, this having low resistance contacts, low self capacity and an insulated spindle which is necessary for the dynatron type of oscillator. In Fig. 8 all switch contacts of the wave change switch together with the spindle of the attenuator switch and the fixing bush and spindle of the variable condenser must be insulated from the screening, so that the case of the generator may conveniently be made of wood with a copper foil covering all over, this being cut away at the indicated points to just clear the fixing bushes and nuts. Fig. 9 is for commercial coils only, having reaction windings.

The coils should not be mounted nearer than 1 inch to the screen or they will suffer a change of characteristics.

The output leads must also be screened, the direct output and Artificial Aerial (A.A.) being taken to coded sockets and contact between these and the gear under test being made by a single screened cable, the screen acting as the earthed return lead.

The A.A. is used for ganging straight sets and the aerial circuits of superhets while the direct output is used for I.F. adjustment.

In both battery and mains types it is desirable that the power supplies are included in the same screened box. If they are mounted externally the high tension leads may need H.F. chokes included at the terminals to prevent unwanted radiation.

All components should be anchored, nothing being suspended in the wiring.

The attenuator of Fig. 8 may be used in Fig. 9 if desired. It is of the ladder type giving steps of times 10 attenuation and the input voltage to it may be measured and adjusted with a valve-voltmeter, built in if desired.

Resistors throughout are of the carbon type except for the inductive resistor included in the A.A. This may be made with a suitable length of resistance wire wound on a glass tube in two or three layers, or it may be an ordinary wire wound resistor.

Once the dynatron circuit of Fig. 8 is in operation it will be found very stable but it may need a little attention at first. Screen

grid valves vary widely in their dynatron capabilities and it is advised that different valves be tried in the circuit, with changes of anode and screen volts, to discover the most suitable. The dynatron may also be made up as a mains operated unit and here the Mazda A.C.S2 will give excellent results with only 100 volts on the screen and about 20 volts on the anode, a variable resistor of 10,000 ohms in the cathode lead to give biasing. This should be bypassed by a .1 mfd condenser and its setting determined by experiment, the moving arm being locked before the generator is calibrated.

To derive the anode voltage for the A.C.S2 a low resistance voltage divider must be used, with good regulation of the voltage.

If commercial coils are used for the dynatron oscillator the reaction winding may be used to feed the attenuator instead of the present tap on the anode circuit. One side of the coil should be taken to earth and the other straight to the 50 ohm variable resistor.

#### Dynatron Coils for Fig. 8.

Condenser .0005 mfd.

Approximate range :

10- 50 metres	7 turns S.W.G.	16 spaced to 1/4 in.
45- 160 "	28 "	20 spaced to 1 in.
150- 500 "	86 "	32 winding length lin.
450-1500 "	205 "	25 bankwound to length of 1/2 in.
900-3000 "	480 "	24 bankwound to length of 1/2 in.

All on formers of 1 in. diameter, all enamelled wire.

#### "P" Type Coils for Fig. 9.

Approximate range :

12- 35 metres	Wearite PA.4
34- 100 "	" PA.5
90- 260 "	" PA.6
250- 750 "	" PA.7
700-2000 "	" PA.1

#### CALIBRATION

The best method of calibrating a Signal Generator is by comparison with an oscillator of known efficiency. The two generators are coupled into a simple detecting device—a one-valve detector working on headphones—through their A.A. circuits with out-puts attenuated to the lowest level possible, and the standard oscillator set at a definite frequency. The generator to be calibrated is then tuned until its signal lies exactly on the standard signal, when the frequencies

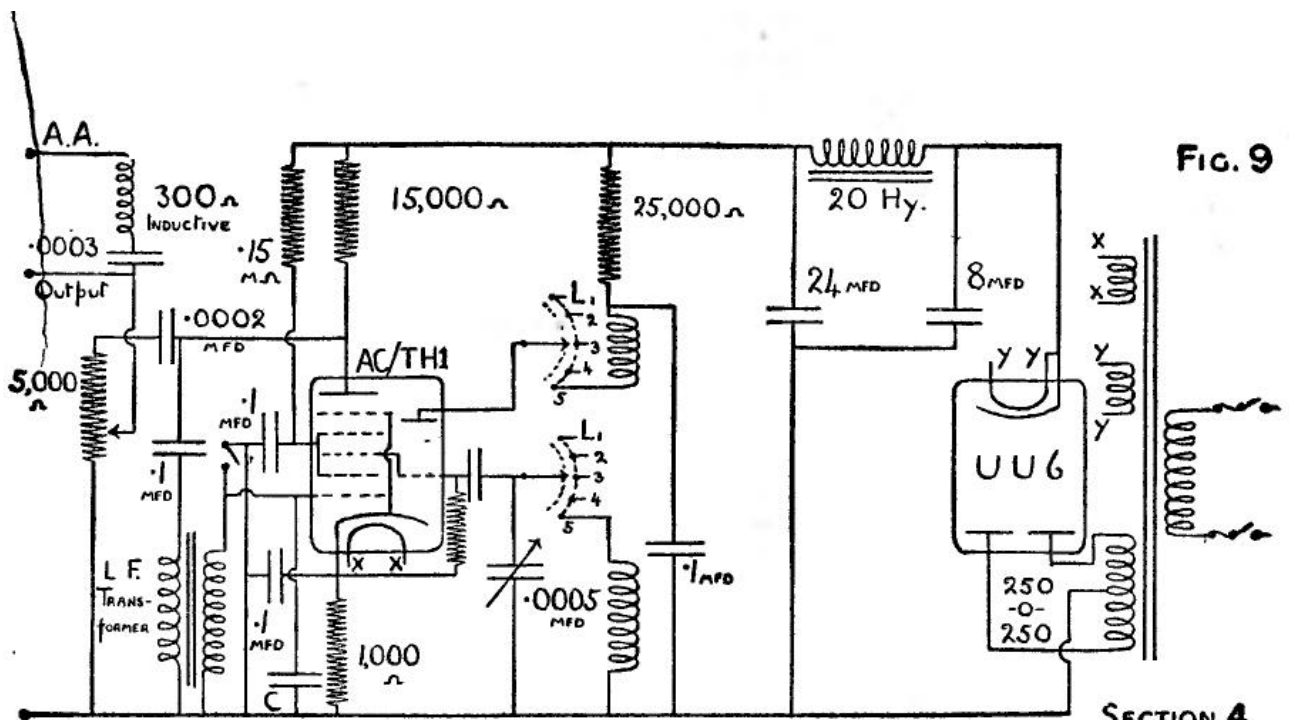

FIG. 9

A.C. MAINS SIGNAL GENERATOR

SECTION 4



will be identical and a series of such points for each range will enable accurate graphs to be drawn from which all frequencies may be plotted.

The outputs must be kept as low as possible, as oscillators working on close frequencies tend to "pull in," the stronger dragging the weaker into step.

If the detecting device is made to oscillate as well, great accuracy of calibration can be achieved. The standard generator is arranged to give a beatnote with the detector, and the generator under calibration is slowly tuned in to produce a second beatnote, which will become slower in frequency until it is a throb superimposed on an audio note. When the most stable condition is reached, the generators once more are in step.

If a calibrated oscillator is unobtainable, however, use must be made of broadcast programmes, together with a receiver capable of bringing in a good selection of stations whose frequencies are known. The receiver is tuned to any suitable station—one giving a tuning signal on a fixed note is very suitable—and the generator tuned to give a beatnote on the station, when its frequency is that of the station. Once again the generator should be coupled to aerial and earth sockets of the receiver through its A.A. and the generator power should be as low as possible. A series of such points will enable a calibration chart to be drawn for each of the broadcast ranges.

This system is simple for the broadcast ranges, but for the I.F. ranges around 450 and 480 kcs. there are no well-known transmitters, nor does the ordinary receiver tune to this band. In this case use must be made of the oscillator harmonics. Almost any oscillating circuit working at a fundamental frequency generates harmonics; should the fundamental be 1,000 cycles, the second harmonic will be 2,000 cycles, the third 3,000 cycles, and so on, the harmonics gradually diminishing in strength as they rise in frequency. Thus at a fundamental frequency of 450 kcs. there is a harmonic at 900 kcs., or 323.3 metres; at 460 kcs. a harmonic at 920 kcs. or 326 metres, and so on. Provided care is taken in choosing the correct harmonic (the second should be sufficient), a series of stations on the harmonic band should easily be found to give sufficient points for a curve of I.F.s.

This method of calibration may require either a modulated or unmodulated signal from the generator, depending on conditions. A clear-cut beatnote over the station frequency is all that is required.

It is useful to remember that wavelength times frequency in cycles per second equals 300,000,000.

#### USING THE SIGNAL GENERATOR

Where a straight set is to be trimmed, the procedure is as follows: Set all the trimmers on the set to half-way positions and connect the output of the set to an output meter, if this is being used. (Sec. 4) Connect the set to the Signal Generator with the screened lead, the lead joining A.A. and Aerial sockets, the screen itself joining the Earth sockets, and switch on.

If the set has a calibrated dial, tune to 250 metres (1,200 kcs.), and set the signal generator at this frequency, when a signal should be heard or registered by the meter. No matter how many stages there may be in the receiver, commence to trim the last radio frequency stage; that is, generally, the grid circuit of the detector, and tune this trimmer either in or out until the modulated signal of the generator is at maximum volume. The generator output should be adjusted so that any change in volume is clearly audible, or that the pointer of the output meter remains within limits. Then trim the next stage, working back towards the aerial, with further attenuation if required, to give any possible improvement in volume, and continue with each stage in turn until all are trimmed and in gang. The calibrated dial of the receiver may now be checked by tuning to 500 metres (600 kcs.), and bringing the generator once more into tune with the set. The generator should also read 600 kcs., and if it does not the set is out of calibration, probably due to faults in either coils or condensers.

For straight sets in which reaction is used, trimming should be carried out in the same way but with reaction advanced to the degree at which it is usually used.

Where sets are not calibrated but have a plain tuning dial, it is often recommended that a slightly different technique is used to make sure that the receiver will tune sufficiently low in the band after trimming. The receiver and generator are set up as described, but the ganged condenser of the receiver is set at its minimum unmeshed position and the Signal Generator tuned to 1,500 kcs. (200 metres). The detector circuit trimmer is then adjusted to give maximum volume or meter reading, but before any further adjustment the Signal Generator is retuned to 1,400 kcs. The tuning of the receiver is altered by the main tuning control till the signal is received again at maximum volume, and the rest of the circuits trimmed at this new setting.

Should the set be unable to reach as high a frequency as 1,500 kcs., it indicates that stray capacities are rather high for adequate band coverage, but the procedure may be carried out using frequencies to suit the receiver.

Generally speaking, only this one set of adjustments will be necessary for straight sets, as the long waves are covered by the same trimmers as the medium waves. If, however, the trimmers are on the coils and not the condensers so that long waves have to be trimmed separately, the frequency chosen for adjustment is most suitably 1,000 metres.

The output from the Signal Generator should always be kept as low as possible to avoid swamping either the circuits themselves or the system of output measurement of the receiver, especially if the ear is being relied upon.

#### SUPERHETS

The different circuits of a superhet receiver are always trimmed or lined up in the order I.F.T.s, Oscillator, and aerial circuits (that is, the signal frequency tuning circuit), and the process should be carried out with an output meter to show the response of the set as a whole. Set up by switching in the output meter and connecting the generator to the signal grid of the frequency changing valve (V1 in Fig. 1), using Output, not A.A., and with Earth to the receiver chassis.

General practice is to put the oscillator out of action while the I.F. circuits are lined up by shorting the oscillator grid coil with a length of wire, but it has been pointed out that this changes the bias on the frequency changer as a whole and thus gives slightly varying conditions. Either method may be tried, although the novice is advised to put the oscillator of the set out of action as described.

I.F.s of sets cannot be changed. The maker's original Intermediate Frequency must be found before the set can be lined up, for the circuits will be working at totally incorrect adjustments if this is not done. The I.F. may be found from a service sheet, from the makers or from lists printed in Trade Journals.

The Signal Generator is tuned to the I.F. and the set and generator switched on. After warming up, there should be a response on the output meter, and the I.F.T.s are trimmed from the detector back, as in a straight set, to give maximum output of the modulated signal. The curve of the response, in this case, however, needs attention and requires to be of the familiar "double-humped" type. In other words, when the I.F.T.s have all been adjusted for maximum response to the I.F., the generator should be set off tune to any other reading. The output meter will, therefore, fall to zero. The Signal Generator, is now slowly tuned back to the I.F. and right through it without stopping, and the meter should respond by rising to a maximum, dipping very slightly, rising to the same maximum and then falling back to zero at the same rate at which it rose, as the generator is tuned away from the I.F. If the meter does not respond in this way, the trimming of the I.F.T.s should be inspected again for faults,

but once they are set and the I.F. determined, these stages of the set should not be touched again.

If used, the shorting link on the oscillator is now removed and the Signal Generator connected to the Aerial and Earth plugs of the receiver, using the A.A. of the generator. The output of the generator, as usual, should be as low as possible.

There are two controls to adjust on the Oscillator section of the superhet, Trimmers and Padders (see Fig. 1), and their functions are to set the ranges covered by the circuit. In general, the trimmer controls the high-frequency end of the range, at about 200 metres, while the lower-frequency end, up to, say, 600 metres, is extended by the padder. The first control to check is the trimmer.

Set the oscillator trimmer to its lowest capacity and switch the receiver to the medium band. Tune the ganged condenser to 214 metres (or as the makers specify) and bring the generator to the same frequency. Slowly screw in the trimmer to maximum response on the meter and stop; other peaks may be found if the trimmer is advanced further, but the first point of maximum response is the one desired.

Now retune the receiver, by its ganged condenser, to 500 metres, and once more set the generator to the same frequency, then adjust for maximum output on the meter by operating the padder condenser.

This, of course, will slightly upset the trimmer, so that both set and generator must be reset at 214 metres and trimmed again, and then returned to 500 metres and repadded, these operations being repeated three or four times until a nice balance between the two adjustments is obtained.

The long wave band will have its trimmer and padder: the set must now be switched to long waves and the same operations carried out at 900 and 1,800 metres, then the short waves, if included, must have their oscillator coils trimmed and padded. At times, however, padding is not necessary on some circuits and no padders, therefore, may be found which makes the adjustments very simple. Tune to any convenient point at the high frequency end of the band, set the generator to the same frequency and adjust the trimmer for maximum response. The calibration of the dial for these unpadded circuits should then be correct which may be checked by tuning over the bands and making sure that signals from the generator are received at the correct wavelength or frequency indicated on the receiver dial; if they are not then faults are present in the oscillator coils under test.

To trim the signal frequency circuits, or aerial circuits, return to the medium wave band and set both receiver and generator to 214 metres. While trimming is in process it is helpful if the ganged condenser is "rocked"—that is turned slightly one way then back

Fig. 10

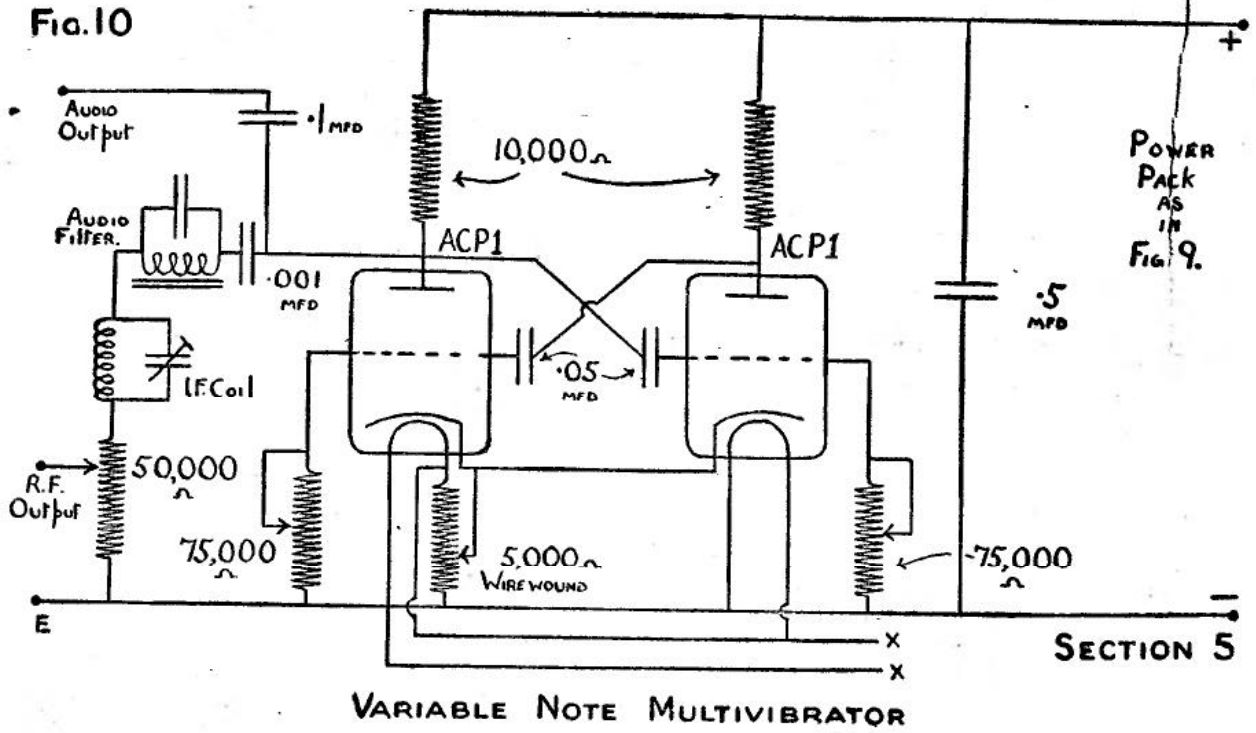

again so that the receiver is being tuned through the generator signal as the trimmer is adjusted for maximum response and the correct reading on the receiver dial. The long waves and short wave bands are dealt with in the same way.

### SECTION 5. MULTIVIBRATORS.

The Multivibrator has recently found wide application in the commercial manufacture of receivers and can be made a very useful piece of equipment without great expense. Its value lies in the fact that while the Multivibrator may oscillate at a fundamental frequency well within the audio range it has a series of harmonics extending deeply into the radio frequencies, and the oscillations may easily be stabilised.

Briefly the action depends on the time constant of charge and discharge of a pair of condensers and leaks arranged in back coupling between the anodes and grids of two similar valves, and the circuit is generally shown as designed for one fundamental frequency, but in Fig. 10 the leaks are variable so that the constants of the circuit may be changed to give a wide range of audio tones suitable for testing reproducers and amplifiers as well as harmonics for use with radio circuits.

As the output has such a large harmonic content it must of necessity, be far from a pure waveform which in laboratory testing might give rise to complications, but for general work this need be no deterrent. The wave form is slightly improved and the fundamental frequency "locked" or stabilised by the injection of a small oscillating or sine wave voltage into either grid, anode or cathode circuits, and this is the function of the variable cathode potentiometer which has been applied to it the A.C. heater volts. To lock the circuit it is only necessary to listen to the audio output on phones or loudspeaker while rotating the potentiometer arm away from the earthed connection. The sound will suddenly change from a harsh note to a clear tone, which will be a harmonic of the 50 cycle supply, and if further locking voltage is applied "dragging" will occur—the note will drop to lower and lower harmonics of 50 cycles as the fundamental locking frequency is approached. This should generally be avoided and the first locking position chosen.

The form in which the radio frequency output is developed is particularly useful. Supposing that the fundamental Multivibrator frequency is 500 cycles (locked with 50 cycles), the harmonics will be separated by this frequency throughout their whole extent so that if the radio portion of the signal is fed into the aerial circuits of either a straight or superhet receiver a continuous note will be heard

all round the dial, one harmonic being tuned immediately after another, and resulting in a 500 cycle note from the loudspeaker.

To trim a straight set, therefore, it is necessary merely to connect its Aerial and Earth sockets with "R.F." output and "E" of Fig. 10 and adjust all trimmers to give maximum volume, the set being tuned to about 250 metres. The tuning condenser is then run through its whole travel to make sure that no particular band is giving a weak or dead spot.

With a superhet the Signal Generator must still be used for lining the I.F.T.'s and trimming the oscillator, but the padding condensers may be adjusted against the Multivibrator, tuning the set as before to 500 metres and adjusting the padder for maximum volume. The trimmer and wavelength settings can then be rechecked by the Signal Generator as usual, which may be left at its setting of 214 metres without being touched (for the medium band), and the balance between trimmer and padder condensers obtained by degrees, using the Signal Generator and Multivibrator as necessary.

For adjusting superbets the L.F. is cut out by a filter shown in the circuit so that there shall be no interaction or break-through, and the audio bands are also cut out by a filter. With the instrument as shown, where the fundamental frequency is variable, this filter may consist of a good L.F. choke bypassed by a small condenser, of .0005 or .001 mfd., but where the fundamental frequency is to be set at any one note the audio filter may be tuned to the same frequency using

$$f = \frac{10^6}{2\pi \sqrt{LC}}$$

where  $f$  is in cycles  $L$  is in Microhenries, and  $C$  is in Microfarads.

The frequency of the Multivibrator is controlled by the grid-anode condensers and leaks and is given by

$$F = \frac{1,000}{R_1 C_1 + R_2 C_2}$$

where  $F$  is the frequency in Kilocycles,  $C_1$  and  $C_2$  are the condensers in Microfarads and  $R_1$  and  $R_2$  are the leaks in ohms.

### SECTION 6. AUDIO OSCILLATORS.

While the general serviceman often has no great use for the audio ranges alone, an audio oscillator can be of value for testing speakers and other reproducers, amplifiers and the L.F. portions of receivers, for supplying A.C. bridges (Sec. 9), or for phase shifts and modulation tests with oscilloscopes.

FIG. 11

10,000 $\Omega$   
MATCHING

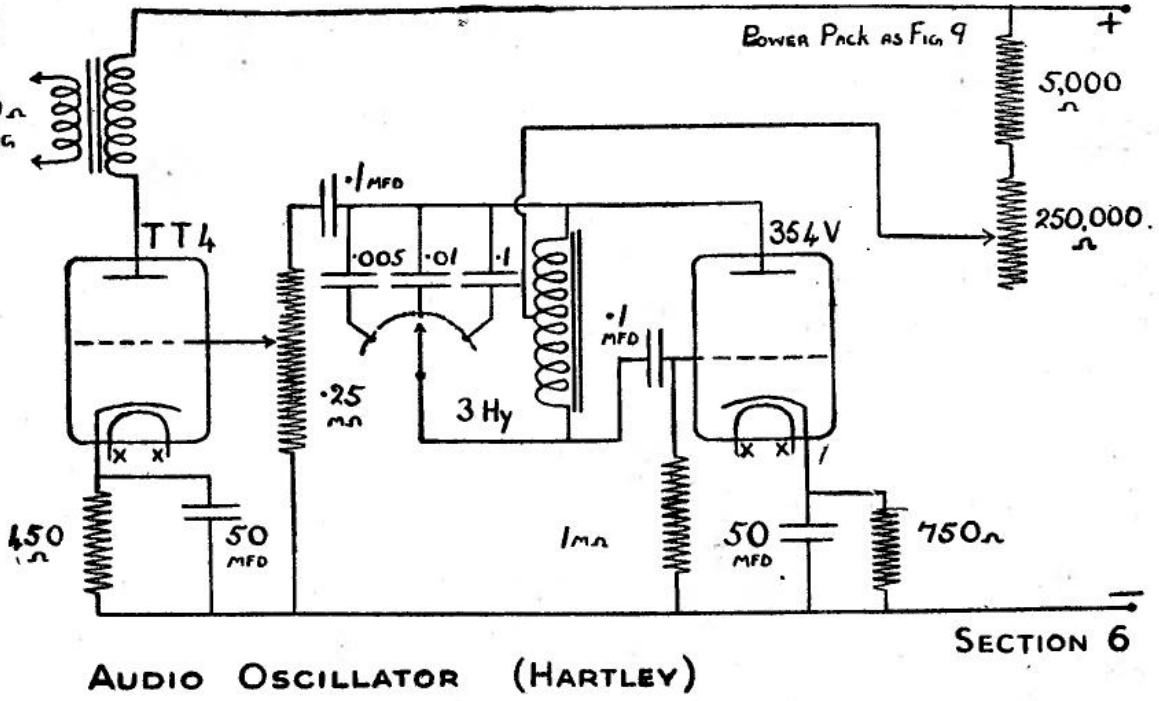

POWER PACK AS FIG. 9

5,000 $\Omega$

250,000 $\Omega$

0.005 MFD

0.01 MFD

0.1 MFD

3 Hy

354 V

1 m $\Omega$

50 MFD

750 $\Omega$

AUDIO OSCILLATOR (HARTLEY)

SECTION 6

Fig. 12

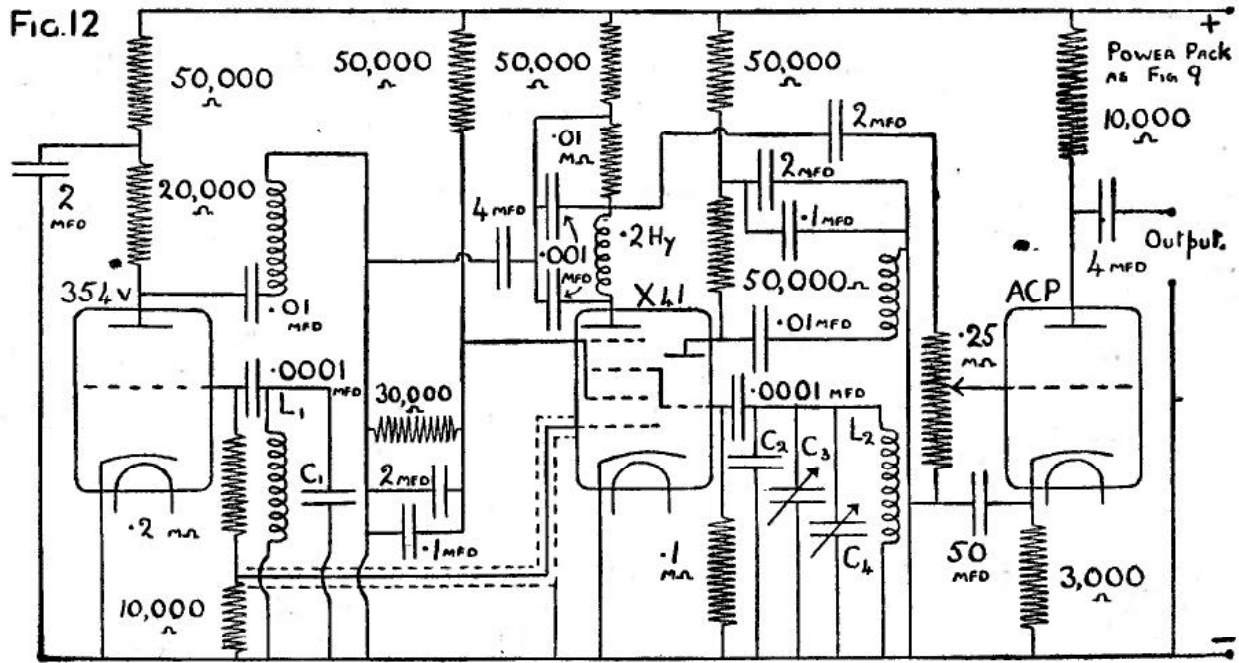

BEAT FREQUENCY AUDIO GENERATOR

SECTION 6

If the waveform of the audio generator must be purely sinusoidal the apparatus can become very involved but for general work this is often unnecessary so that iron cored chokes may be used either in an anode feedback circuit, such as the pentode portion of Fig. 9, or in the Hartley oscillator circuit of Fig. 11.

The frequency generated is tuned in the usual way by means of a condenser in parallel with the inductance, and with the Hartley circuit shown as many condensers as frequencies desired may be switched in to give varying notes, the frequency being given by

$$f = \frac{1}{2\pi\sqrt{LC}}$$

where  $f$  is in cycles per second,  $L$  is in Henries and  $C$  is in Farads.

The less the power taken from the circuit the better will be the waveform, so that a buffer amplifier is included in the diagram. With this the voltage on the oscillator valve, and thus the current, may be reduced to the minimum required for maintaining good oscillation, the rheostat in the anode circuit providing this control.

In some cases, however, a continuously variable audio frequency is required, and Fig. 12 shows a Beat Frequency Generator suitable for experimental purposes. Unfortunately this is a difficult piece of apparatus to build and operate really well, and it must be noted that the circuit shown is capable of wide and varying developments.

Briefly the system is to beat or heterodyne two high frequencies, one against the other, one being fixed and the other variable, separating out the beat note after rectification. The first circuits, therefore, are working on radio frequencies and any stray coupling between them will lead to pulling-in, particularly since they have such similar characteristics. Each circuit must be enclosed in its own screening box and H.F. connections made by screened cable as shown, while greater freedom from pulling-in may be achieved by feeding the two signals to a push-pull detector system.

For good waveform and stability it is sufficient to make the fixed frequency oscillator of the desired characteristics, and different frequencies may be tried as fundamentals although for experiment it should be sufficient to commence with  $L_1$  and  $L_2$  of 170 microhenries, the respective anode coils being sufficient to maintain oscillation—say one fifth of the grid coil turns.  $C_1$  and  $C_2$  are more easily variable than the coils and it is suggested that for first trials they be made .005 mfd. with  $C_3$  the main control .0005 or .001 and  $C_4$  the "zero setter" of .00005 mfd.

In both circuits resistors are best of the carbon type except for the variable resistor of Fig. 11, and condensers should be non-inductive.

Audio Oscillators are often left uncalibrated for ordinary work, a range of notes being all that is desired, but if calibration is necessary it may be carried out by comparing the signal with that obtained from a standard calibrated oscillator, both signals being fed into the same reproducer through buffer amplifiers and adjusted for zero beat note. Failing this the oscillator under test may be compared with a standard frequency record such as those prepared by H.M.V. Such records are a valuable source of audio frequencies, being made under strict control with exact frequencies and output levels stated.

For a rough and ready check, however, the oscillator may be compared against a piano although the notes will differ in tone due to the instrument's harmonics. A scale of keys with corrections for pitch and a diagram of frequencies is given in "Direct Disc Recording," No. 37 in Bernard's List.

## SECTION 7.

### OUTPUT METERS.

Some of the uses of an Output Meter have already been described and as almost any A.C. instrument may be used as the measuring device—valve-voltmeter, A.C. ranges of the analyser or Thermammeter—it need not be an expensive piece of apparatus.

The circuit of Fig. 13 shows the method of using either voltage or current measurements on a 10 ohm resistor, but if one method is decided upon it may be advantageous to adapt the resistor value, making it even lower for current readings or higher for voltage indications.

In either case the actual power is obtained from

$$\text{Watts} = \frac{V^2}{R} \text{ or } \text{Watts} = I^2 R$$

and a table is given in Fig. 13 showing the voltages and currents to be expected in the 10 ohm resistor for outputs of 1 to 5 watts.

The instruments may be uncalibrated in which case it will be possible to use the Meter purely for comparison checks, while calibrated instruments will allow actual outputs to be measured either by simple calculations or by a new calibration direct in watts.

The important point to remember is that whatever value of resistor is used in the output circuit it must be matched to the

Fig. 13

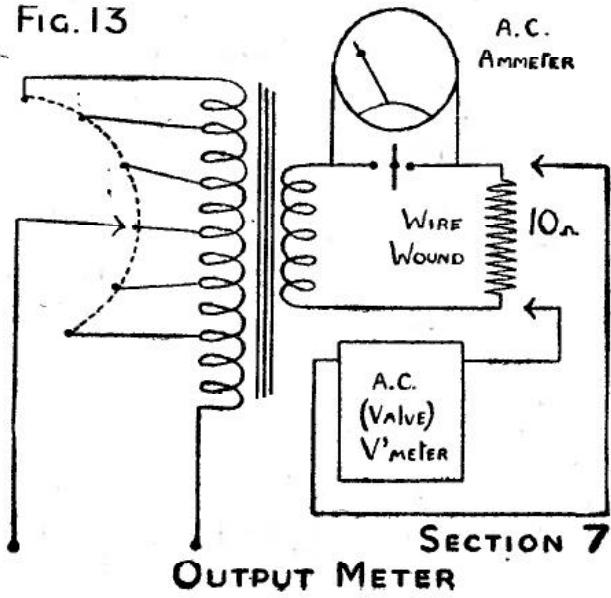

READINGS WITH 10 OHM RESISTOR.

WATTS	CURRENT	VOLTS
1	.32 AMPS	3.2 VOLTS
2	.45 AMPS	4.5 VOLTS
3	.55 AMPS	5.5 VOLTS
4	.63 AMPS	6.3 VOLTS
5	.71 AMPS	7.1 VOLTS



optimum output load as stated for the output valve being used, this matching being performed by a tapped output transformer as shown. The ratio to be used is given, as before, by

$$\text{Ratio} = \sqrt{\frac{\text{Optimum Anode Load}}{\text{Impedance of output circuit}}}$$

and generally speaking the resistor will have so little self inductance that the impedance may be taken as the resistance in ohms. For the case in point, therefore, the ratios of a transformer to match the 10 ohm resistor to stated loads of, say (1) 3,000 ohms; (2) 5,000 ohms; (3) 7,000 ohms and (4) 10,000 ohms, would be

- (1) 17.3 to 1
- (2) 22.4 to 1
- (3) 26.5 to 1
- (4) 31.6 to 1

Such a transformer may be bought or made, but if a tapped transformer with different ratios is already to hand a simple inversion of the formula will give a suitable resistance, "X", to be used with it. As the ratio is known the formula becomes

$$X = \frac{\text{Optimum anode load}}{\text{Square of the ratio}} \text{ or } X = \frac{L}{R^2} \text{ ohms}$$

For example, if it is required to measure the output of a Pen 45, using a 50 to 1 output transformer, the valve load being 5,200 ohms,

$$X = \frac{5,200}{50^2} \text{ or } 2 \text{ ohms nearly.}$$

A resistor of 2 ohms would be included in the secondary circuit of the transformer and as only a small voltage would be set up across such a resistor the current through it would be measured by a Thermo ammeter. For an output of 4 watts the current expected would be  $4 = I^2 R$  or  $I^2 = 2$  and  $I = 1.414$  amps.

Actual output measurements, of course, must be made on a steady signal as supplied by a modulated Signal Generator or Audio Oscillator. Speech or music will obviously give fluctuating readings.

The calculations and examples as shown above all neglect transformer losses and power consumed by the internal resistances of the instruments used, but these should all be small. Corrections may easily be made if desired, meter resistances being in series with the load for currents and in parallel for voltages.

## SECTION 8.

### VALVE TESTS.

Despite the great number of tests which may be applied to valves of all types it is quite common for both shops and servicemen to do no more than check the continuity of heater or filament and roughly test the emission of a suspected valve. Such tests are not sufficient; the emissions of two filaments or cathodes of the same batch might vary considerably, whilst there may be no indications, with such a test, of shorting electrodes or such faults as heater-cathode leakage in mains valves. If valve testing is to form an important part of service work it is advisable to obtain a testing panel from a recognised firm, but for ordinary service checks the two circuits of Figs. 14 and 15 should provide a satisfactory outfit. They may quite simply be combined, but in the writer's opinion it is good practice to keep such apparatus uninvolved. The range of valves is so great that a most comprehensive set of holders and panels is needed if all types are to be accommodated, and so these circuits, fitted with crocodile clips to connect easily to any valve in its individual holder, will certainly be cheaper and probably more convenient.

Fig. 14 is of a test circuit for checking mutual conductance and Fig. 15 for checking the amplification of a valve, while the valve's anode resistance is found by dividing the amplification factor by the mutual conductance and multiplying by 1,000, the answer being in ohms.

### TESTING THE VALVE.

Before any other tests, the valve should be checked for shorting electrodes. Nothing more than a 100 volt battery and a suitable neon lamp are required, the battery and lamp being connected in series, with one side of the battery taken to a valve pin and the free side of the lamp to any other pin, care being taken to have insulated test leads or clamps. The insulation of each electrode to its fellows may then be tested, the valve being very gently tapped from time to time, special care being given to the insulation between cathode and heater of a mains valve. Any breakdown here may lead to bad hum effects, while with valves of A.C./D.C. types, particularly restifiers, it might lead to a complete short circuit of the mains supply. There may also be emission effects between heaters and cathodes, traceable by substituting a milliammeter for the neon lamp and reversing the applied potential to the electrodes. If the current does not vary it is a plain leakage current; an emission current will vary.

If the leak leads to hum in the receiver the valve should be changed.

FIG. 14

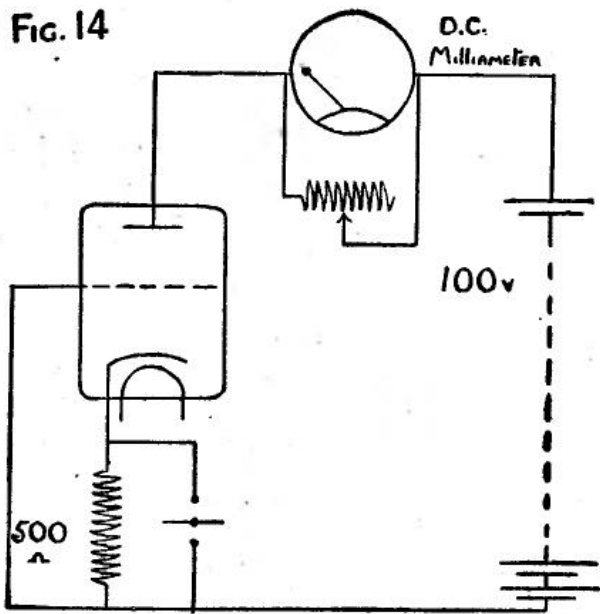

MUTUAL CONDUCTANCE TEST-SET  
SECTION 8.

FIG. 15

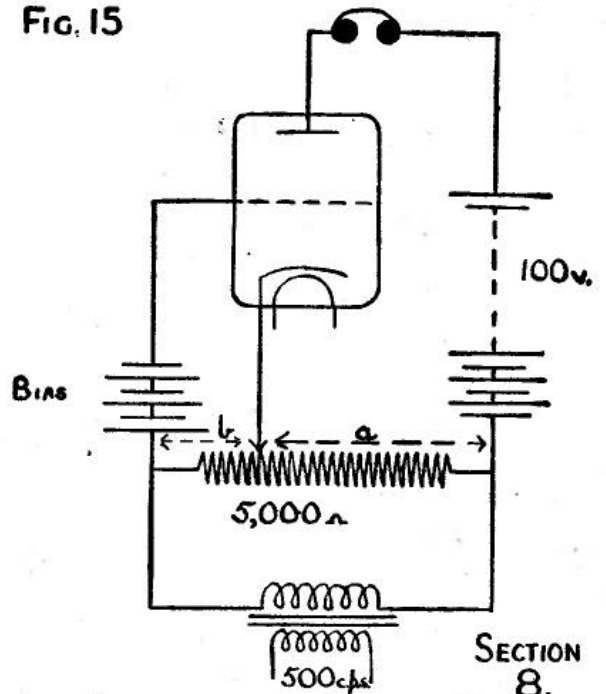

SECTION 8.  
AMPLIFICATION FACTOR TEST-SET

If all electrodes are properly insulated and the heater is in good condition (high voltage heaters may develop partial short circuits, traced by a current consumption check), the valve may now be checked for mutual conductance. Connect it into the circuit of Fig. 14, the cathode resistor being short-circuited by the switch, and adjust the milliammeter to full scale current by the variable resistor across it, this being chosen to suit the instrument internal resistance. The switch is then opened, giving a lower current reading and the mutual conductance is obtained by

$$G_m = \frac{I_1 - I_2}{I_2 \times R} \frac{1}{R_A}$$

where  $G_m$  is the mutual conductance,  $I_1$  is the first reading,  $I_2$  the second reading,  $R_A$  is the anode resistance of the valve and  $R$  is the 500 ohm cathode resistor. Generally speaking  $R_A$  will be so high that its reciprocal may be ignored.

The amplification factor is then measured by connecting the valve to the circuit of Fig. 15. The bias is made suitable according to the valve characteristics and an audio note fed from a generator (Sec. 6) into the circuit, the transformer being the audio oscillator output matching transformer. The slider of the potentiometer is then varied until the note audible in the headphones either fades out

or reduces to its lowest point. The ratio of the resistances  $\frac{a}{b}$  will then equal the amplification factor, and it is advised that a good potentiometer be obtained with equally spaced wire winding of the element so that the distances between the limits of the moving arm's travel may be calibrated into, say, 100 equidistant points. This ratio may then be read off very simply and with adequate accuracy.

The anode resistance may then be calculated as shown above, and the valve characteristics so determined may be compared with catalogue figures or with standard valves. As a general rule it may be stated that a valve has reached the end of its useful life when the mutual conductance falls to 60 per cent. or 70 per cent. of the rated figure.

It must be noted in these tests that any valves other than triodes must have suitable voltages fed into screen grids, etc., preferably from separate batteries.

Blue glow or fluorescence in valves, particularly output and rectifier valves, may be noticed, but whilst these effects appear similar blue glow, generally between cathode and plate, indicates the presence of a slight amount of gas while fluorescence, generally on or by the glass bulb, indicates a good vacuum. Quite a considerable amount of glow may be tolerated, however

A microphonic valve should be easily detected, the effect being due to mechanical vibrations from the loudspeaker or other sources causing movement of the electrodes and therefore changes in valve current which will produce howls or other noises. Gently tapping valves whilst they are in their working positions will generally suffice to show which valve is at fault. There is no real remedy apart from replacing the valve, although the effect of damping the offender with wadding or rubber may be tried, a packing being wrapped round the bulb and tightly secured.

Other noises due to valves are hissing, crashing or crackling, but generally dirty contacts or dry joints are responsible for these effects.

If valves are to be tested while in their original circuits the best method is to check anode and screen currents. Each lead has a milliammeter included in circuit in turn and the voltage on the electrode under test should be checked with a high resistance voltmeter. The results obtained are checked, as usual, with the makers' figures.

## SECTION 9.

### COMPONENT TESTING.

In many cases elaborate testing of suspected components is unnecessary. The Continuity Tester of Fig. 2 and the use of an Analyser will often be sufficient to make such tests as checking small condensers for short circuits, testing the windings of all types of transformers by checking their continuity and resistance, testing the resistance of switch contacts and tuning coils, checking resistors and other such routine tests. Sometimes, however, more searching checks must be applied and in these cases a number of auxiliary pieces of equipment can be of great assistance.

Generally speaking the most adaptable and useful apparatus is the bridge in one or more of its forms. In Figs. 16, 17 and 18 are shown the circuits of Wheatstone's bridge, a simple condenser bridge and Owen's Inductance bridge, and should all these be thought necessary they may quite easily be built into one circuit with switching devices to control the applications.

Wheatstone's bridge is particularly useful, for practically any resistance can be either checked or calibrated on it. It consists of four resistance arms, three of which are controllable, the fourth, shown as "X" being the unknown resistor. Arms "a" and "b" are termed the ratio arms and in the diagram are shown as tapped resistors which allow 10, 100 or 1,000 ohms to be put into either side. In this way the ratio  $\frac{a}{b}$  can be made 1:1, 1:10 or 1:100

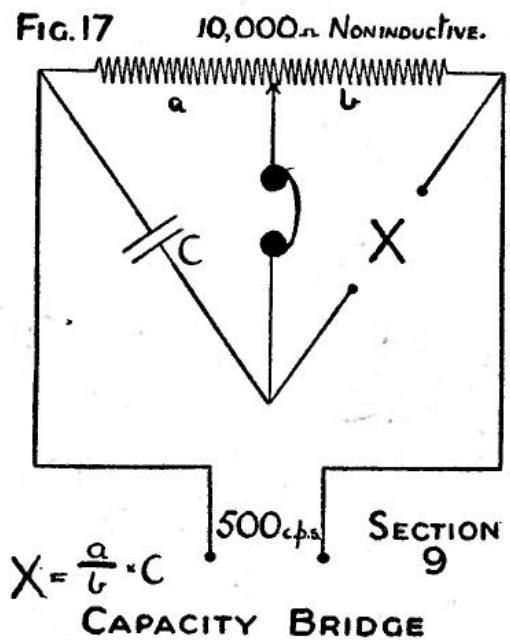
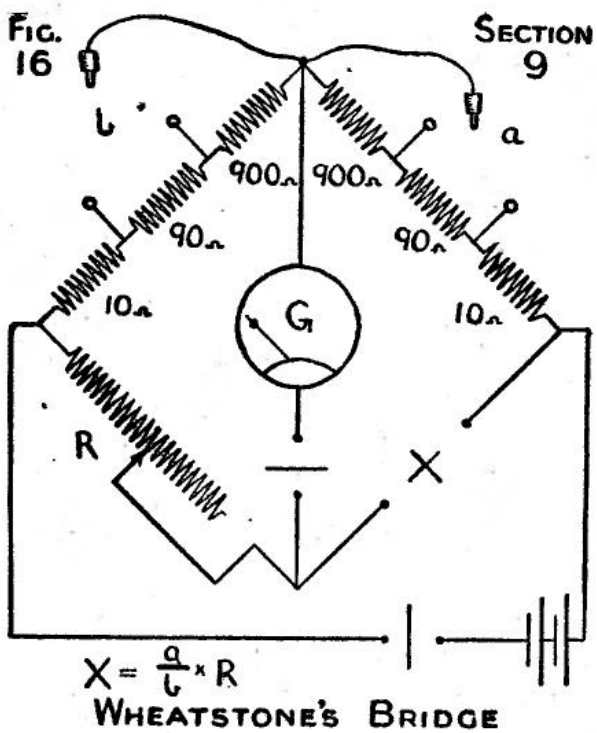

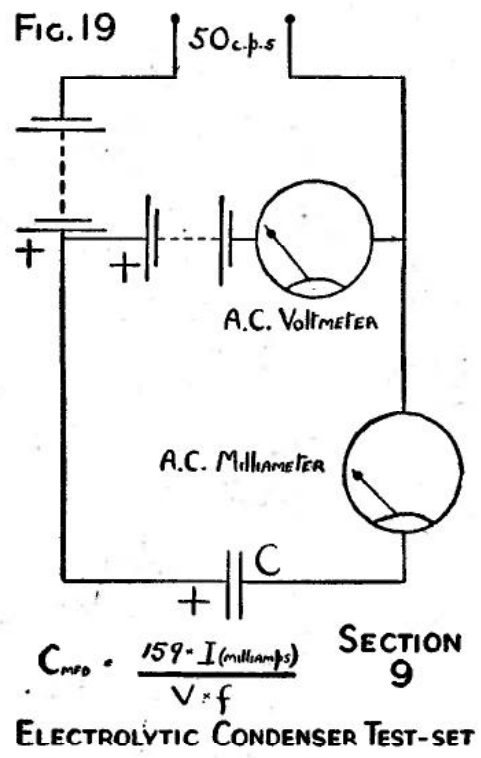
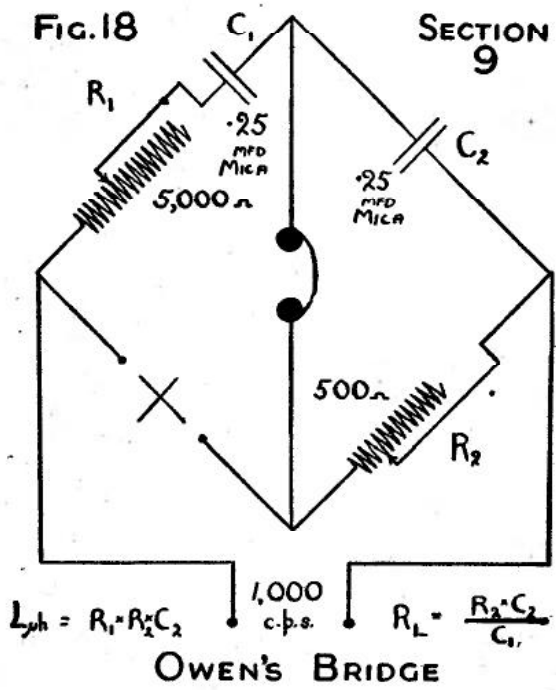

and as many further sections as desired may be added although the ratio should be kept as near to 1:1 as possible to give the highest degree of accuracy.

The arm marked "R" is a calibrated resistor and should the resistances to be checked be low then "R" should be of a relatively low value as the accuracy of reading is better as each arm becomes more nearly the value of the others. "R" could consist of a calibrated potentiometer but as so much depends on the accuracy of its setting it should be the best and most accurate resistor possible to obtain. The Post Office Box is a complete Wheatstone bridge and if one is procurable it will prove an excellent investment. All resistances can be made and calibrated with it.

The bridge is set up as shown, with as low voltage a battery as will give good indications—say 4 volts—with "G" a sensitive galvanometer. If the rough value of "X" is known set "R" to that value and the ratio arms to 1:1, close the battery switch and flick the galvanometer switch closed and open again. The galvanometer will probably swing over hard, and the bridge is adjusted by changing the value of "R" until the Galvanometer gives no indication when the switch is closed. When this is the case and the ratio arms are set to 1:1 the value of "R" will equal the unknown value, whilst for other ratios

$$X = \frac{a}{b} \times R$$

The condenser bridge of Fig. 17 may very easily be made, for generally indications of capacity are all that is required although the bridge will give quiet accurate readings, the accuracy depending on the standard condenser "C". There may be more than one condenser in this position, better accuracy being obtained by making "C" as near in value to "X" as possible, but for rough indications any paper or mica condenser to hand may be used. The bridge is set up as shown and fed from an audio oscillator (or by a low voltage-output transformer from 50 cycle A.C. mains), and the slider of the potentiometer is varied until the note in the headphones either vanishes or fades to its lowest value. The capacity of "X" may then be

found by the ratio of the resistances  $\frac{a}{b}$  multiplied by the value of

"C". As in the case of Fig. 15 it is suggested that the potentiometer be calibrated by dividing up its arc of travel into sections (say 1.100) when the ratio is immediately read off.

Owen's Inductance bridge is a more elaborate piece of apparatus but it is invaluable if experiments on tuning coils are being made, or if coils and I.F.T.'s are being constructed. It needs two properly

calibrated resistors and two identically equal mica condensers and must be fed from a higher audio frequency source of at least 1,000 cycles. To measure the inductance in microhenries of a coil it is connected at "X" and "R<sub>1</sub>" and "R<sub>2</sub>" adjusted simultaneously until the sound fades to a minimum or disappears. Then L in microhenries =  $R_1 \times R_2 \times C_2$  but for a very accurate result the "X" terminals can be short-circuited and the bridge again balanced by a further adjustment of "R<sub>1</sub>" to, say, "r". Then L in microhenries =  $(R_1 - r) \times R_2 \times C_2$ .

To determine the "Q" of a coil it is necessary to know its dynamic resistance RL and this is given by the Owen bridge as  $RL = \frac{R_1 \times C_2}{C_1}$  ohms.

Fig. 19 illustrates a method of measuring the capacity of an electrolytic condenser "C", not easily performed on a bridge due to the necessity of maintaining a polarising voltage on such condensers. The 50 cycle A.C. voltage is derived from a low voltage transformer working on the mains while the A.C. voltmeter may be the suitable section of an Analyser with the A.C. milliammeter of the Thermoelectric type. The batteries which maintain the polarising voltage should both give the same voltage and this voltage, for safe working, should be twice the R.M.S. voltage of the transformer. If the milliammeter is of limited range obviously the voltages of the transformer and batteries may be changed to give a suitable current reading so long as "C" is roughly known.

$$"C" \text{ in microfarads} = \frac{159 \times I \text{ (milliamps)}}{\text{A.C. volts} \times f \text{ (50 cycles)}}$$

It is often required to know the inductance of smoothing chokes but to measure these by bridge methods is difficult as they have a D.C. rating, the D.C. flowing having an effect on their inductance. Accordingly, they may be tested on the circuit of Fig. 20. A battery, D.C. milliammeter and variable resistor may be put in or out of circuit as desired to give controllable D.C. in the choke which is connected at "X" and the impedance of the choke is compared with that of a standard resistor by operating the switch "S2" to obtain readings on a valve voltmeter. The impedance is then obtained by

$$\text{Imp. in ohms} = \frac{\text{A.C. volts across choke} \times 1,000}{\text{A.C. volts across resistor}}$$

and the inductance is given by

$$\text{Inductance (henries)} = \sqrt{\frac{\text{impedance}^2 - r^2}{(6.28 \times \text{frequency})^2}}$$

where "r" is the D.C. resistance of the choke.

FIG. 20

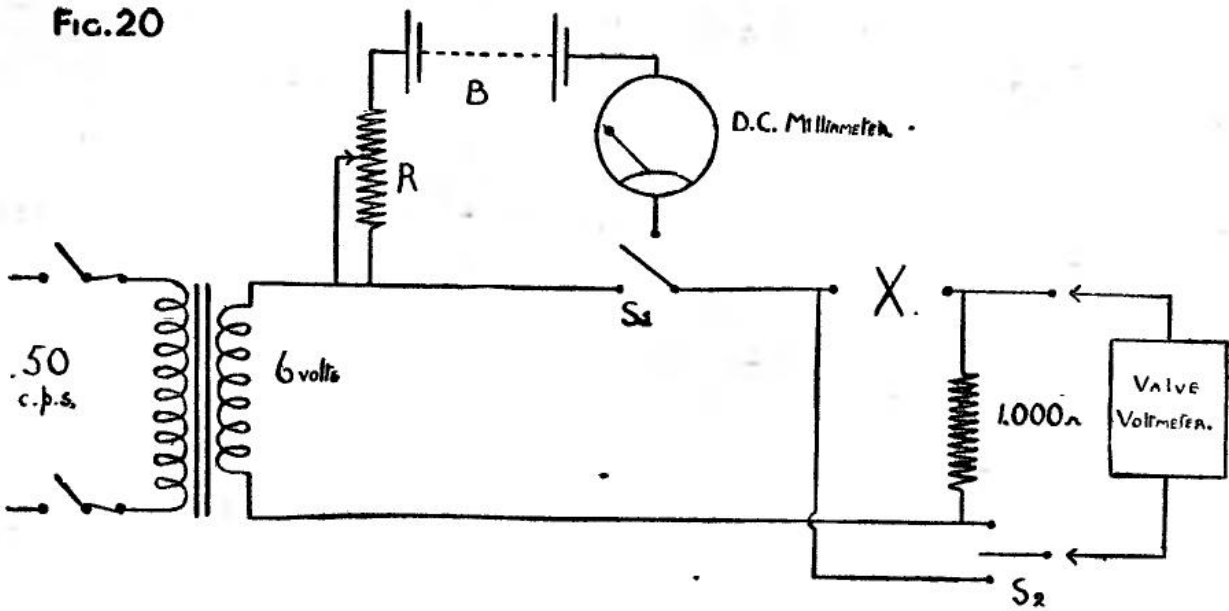

HIGH INDUCTANCE TEST-SET  
SECTION 9

"H.J." Service, London, N.8.

### BERNARDS' TECHNICAL BOOKS.

No. 1	Amalgamated Engineering Ref. Tables ...	1/-
" 2	"Little Marvel" Vegetable Ref. Book ...	1/-
" 3	Services Signalling Manual ... ..	1/-
" 4	Radio Manual ... ..	1/-
" 5	Elements of Mathematics ... ..	1/-
" 6	Electrical Engineers Handbook ... ..	1/-
" 7	Manual of Metals and Alloys ... ..	1/-
" 8	Manual of Modern Automatic Guns' ...	1/-
" 9	Manual of Photography ... ..	1/-
" 10	Manual of Mathematical Tables ... ..	1/-
" 11	Manual of Cycle Maintenance and Hints ...	1/-
" 12	Manual of Commando and Guerilla Tactics: Unarmed Combat	1/-
" 13	Manual of Commando and Guerilla Tactics: House to House Fighting	1/-
" 14	Manual of Small Arms and Special Weapons	1/-
" 15	Manual of Wartime Household Repairs	1/-
" 16	Illustrated Engineering Practice ... .. Machine tools and productive processes	2/-
" 17	Manual of Rifles, usual series ... ..	1/-
" 18	Weapons and Armaments of the Modern German Army ... ..	2/-
" 19	Manual of Map and Compass Reading ...	2/-
" 20	Manual of Gliding and Motorless Flight ...	2/-
" 21	Manual of Science. Mechanics, Physics, etc.	2/-
" 22	Manual of Radio Circuits, ... .. How to build your own receivers and transmitters	2/-
" 23	Manual of Hand Grenades, Mines and Bombs	2/-
" 24	Uniform, Rank Badges and Intelligence Data on the Modern German Armed Forces	2/-

No. 25	Strategy and Tactics of the German Army	2/-
" 26	Tanks at War—Friend or Foe? ... ..	2/-
" 28	Income Tax for the Working Man ... ..	1/-
" 30	Manual of Radio Valves, British and American with Characteristics and Data-equivalents and alternatives ... ..	3/6
" 31	Explosives.—Nature, variety and uses as Projectile Fillings, Propellents, Mines, Demolition Charges, etc., etc. ... ..	2/-
" 32	You can Fly. ... .. Flying made easy, fully illustrated	2/-
" 33	Invasion Tactics ... .. Here and on the Continent	2/-
" 34	Guerillas v Tanks ... ..	2/-
" 35	Mathematical Dictionary ... ..	2/-
" 36	Defence against Gas ... ..	2/-
" 37	Manual of Direct Disc Recording ... ..	2/-
" 38	Aeronautics Illustrated ... ..	2/-
" 39	Tool Makers' and Engineers' Manual ...	1/-
" 40	Carpenter's Handbook ... ..	1/6
" 41	Wireless Amplifier Manual ... ..	2/-
" 42	Short-Wave Radio Handbook ... ..	2/-
" 43	Modern Radio Test-Gear Construction	1/6
" 44	Rapid Radio Repairs ... ..	4/6
" 45	Radio Reference Handbook ... ..	4/6

### BERNARDS' FICTION SERIES-

No. 27	Fighter Controller by S/L J.D.V. Holmes, R.A.F.V.R A tale of the R.A.F. based on Fact	2/-
No. 29	Did this Really Happen? by S. Gainsley Short Stories at their best ... ..	1/6