

RADIO

EXPERIMENTAL
CIRCUITS

MANUAL

PUBLICATION N° 72

2/6

LONDON CENTRAL RADIO STORES

EX-U.S. ARMY ULTRA LIGHTWEIGHT HEADSETS

Deaf-aid type earpieces 3/4-in. dia. with soft rubber ear fittings. 100 ohms. Brand new and packed **23/6**



TELEPHONE LINE OR UNISELECTOR SWITCHES



4- or 6-bank, 26 constants. Have various applications including automatic tuning, circuit selection, etc. Operates on 25-50v.

3-bank	25/-
6-bank	30/-

EX-RADAR VIEWING UNITS.—Consisting of 6" diameter electrostatic C.R. tube; 7 valves, including 4 EF 30, potentiometers, resistances and other components. In metal cabinet, 18x8x2 1/2 in. Bargain price £37/6, carriage extra 7/6.

TWIN ELEMENT HEAVY DUTY sliding resistances, in the following sizes:

5.4 ohm. at 20 amps.	47/6
10 ohm. at 5 amps.	35/-

MOVING COIL HEADPHONE OR MIKE INSERTS.—Voice coil res. 30 ohm, 5/- each.

EX-G.P.O. ELECTRO MAGNET COUNTERS.—500 ohm. D.C. coil, count up to 9,999, operate from 25-50 v. D.C., numerous applications 5/6 each.

SLIGHTLY CONVERTED TO FRACTIONAL H.P., A.C. MOTORS about 1/40, 220-230 v., about 5,000 revs., double-ended spindle, overhead, 10 in. x 4 in.—25/- (carriage and packing 2/6).

23, LISLE STREET, LONDON, W.C.2 Telephone: GERard 2949



We specialise in supplying complete kits and individual component parts for all circuits described in

Bernards' Radio Publications

Write for detailed list of components for the circuit(s) you wish to build.

Send 2½d. stamp for our BROCHURE of KITS, COMPONENTS, etc.

HENBEST BROS., LTD.
26 Green Lanes, London, N.13

Telephone: BOWES PARK 6289

TWO AMPLIFIERS

covering all normal requirements for the highest quality record reproduction.

THE CONCERTO—12 watts—8 triodes plus rectifier. Separate treble and bass controls with two steps of bass boost. £27.10s.

THE KI—5 watts—7 valves. Compare this specification with any other 5-watt amplifier in this price region. Push-Pull with negative feedback, distortion less than 1 per cent. Separate treble and bass controls. 17 gm. Available as a kit, 12 gm. Blueprints separately, 2/6.

Both Amplifiers are designed to take any type of Pick-up, Moving Coil, Moving Iron, or Crystal, without additional pre-Amplifiers or Tone correctors. Radio input sockets are provided and tapped output transformer provides 15, 7 and 3-ohm impedances.

Send stamp for fully illustrated catalogue of Amplifiers, Pick-ups and Speaker.

CHARLES AMPLIFIERS Ltd.
1c, Palace Gate
Kensington, W.8
(WESTern 3350)

RADIO EXPERIMENTAL CIRCUITS MANUAL

RADIO
EXPERIMENTAL
CIRCUITS MANUAL

by
"RADIOTRICIAN"



BERNARDS (PUBLISHERS) LTD.
LONDON

First Printed 1948.

CONTENTS

	Page
Chapter 1. Experimental Circuits in Radio Design	7
Chapter 2. Experimental Circuits in Audio Design	20
Chapter 3. Experiments in Television Reception	33
Chapter 4. Experiments in Amateur Transmission	46
Chapter 5. Experimental Gear for the Test Bench	54

Printed in Great Britain by
KNAPP, DREWETT & SONS, LTD.,
30 Victoria Street, London, S.W.1

CHAPTER 1

EXPERIMENTAL CIRCUITS IN RADIO DESIGN

The aim of this Manual is to present to the radio enthusiast and home experimenter a number of circuits, both old and new, which may be developed for particular uses, or which may be incorporated with existing equipment to give a wider range of functions, or, again, with which experiment is well worth while for its own sake and for the practice and experience gained.

The Manual is broadly divided into five main sections, dealing in turn with Radio, Audio, Television, Transmission and Testing experiments.

THE INFINITE IMPEDANCE DETECTOR

The Infinite Impedance Detector is by now well known to the amateur, especially the constructor of communications and similar short-wave receivers of the superhet class, but is still not widely used in commercial receivers. A disadvantage of the circuit is that A.V.C. control directly from the detector is not possible, so that a separate A.V.C. diode is necessary, but for high quality reception, or for use with a highly selective circuit, the infinite impedance detector has much to recommend it. The circuit of an infinite impedance detector is shown in Fig. 1.

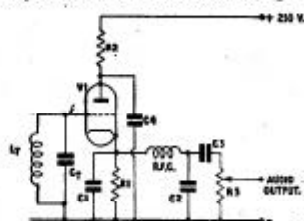

FIG. 1. The Infinite Impedance Detector.

It will be seen that the circuit is based upon the cathode follower principle, a cathode follower, broadly described, being a stage where the output is taken not from the anode of the valve in the usual manner, but from the cathode. In the first place, this results in the output signal remaining in phase with the input signal to the valve grid, but, more particularly, the stage operates with a very high percentage of negative feedback and is thus a "linear" stage—a high quality output is possible.

A cathode follower cannot amplify. The input and output voltages are virtually connected in series, so that the output voltage must be slightly lower than the input voltage, allowing for loss or valve drive, but so far as the detector is concerned this is of little moment, since a diode, usually performing the function of detector, also does not amplify. The actual gain of the triode connected as a cathode follower is $\frac{A}{A+1}$, where A is the amplification factor of the stage, without feedback—that is, with the load resistance in the anode instead of the cathode circuit, and

$$A = \frac{\mu R}{R + r_a}$$

where A is the stage gain, μ is the valve amplification factor, R is the load resistance, and r_a is the valve resistance.

The cathode follower, moreover, beats the Miller effect common to all valves and most pronounced in triodes. A valve has an input and an output capacitance existing between the electrodes, the output capacitance acting as a shunt and by-passing a portion of the output voltages. One of the phenomena associated with the Miller effect is the apparent rise in output capacitance with amplification—the actual grid-anode capacitance is apparently multiplied by the stage gain, so that the shunting effect on high frequencies can be, and often is, serious. In the cathode follower, however, with the cathode potential rising and falling in sympathy with the grid potential, the grid-cathode capacitance is apparently reduced, so that the circuit can deal effectively with very high frequencies and give very low losses, whilst the input impedance is also kept high.

This is of particular value when the cathode follower is to be used with a tuned circuit, as is the infinite impedance detector. The selectivity, or sharpness of the response curve, of a tuned circuit falls as the loading on the circuit increases, and, for a fixed input impedance such as is presented to a tuned circuit by the grid of a valve, the selectivity and also the efficiency of the circuit falls as the frequency rises, since the shunt impedance falls with a rise in frequency. In a television receiver, for example, the efficiency of the tuned circuits is reduced to a serious degree by the shunting input impedance of the valve.

Using the infinite impedance detector, however, an almost infinite impedance is presented to the tuned circuit, with the result that the circuit Q remains high, selectivity remains high, and yet the output impedance of the stage as a whole is low, and easily coupled to succeeding stages.

The infinite impedance detector acts as a cathode follower only so far as audio frequencies are concerned, for the load resistance in the cathode line, which also acts as the bias resistance, is by-passed by a capacitance for R.F. The usual value for this circuit is 100 mμfd.—higher values will by-pass audio frequencies if only to some slight extent, the ideal requirement being a capacitance which will pass radio frequencies with negligible impedance and yet present to audio frequencies an infinitely great impedance.

The chief interest of the infinite impedance detector from the experimental point of view, however, is that it can be made to oscillate. This is because the by-pass condenser, C1 in Fig. 1, is actually in series with the

grid-cathode capacitance within the valve, so that these two capacitances together form a voltage divider across the tuned circuit. In the same manner that a voltage divider using capacitances is used in the Colpitts oscillator, shown in Fig. 2. If the by-pass condenser is reduced in size until it approaches the value of the grid-cathode capacitance, the circuit will progressively become less stable, the impedance presented to the tuned circuit will approach infinity and the losses of the tuned circuit will be neutralised, so that oscillation will be possible.

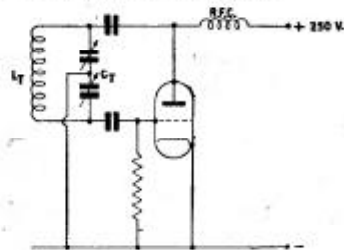

Fig. 2. Colpitts Oscillator, for comparison with Fig. 1.

In the majority of cases the grid-cathode capacitance is very small by ordinary standards—of the order of 10 or 5 mμfd. and less, so that it is possible for the infinite impedance detector to be stabilised by stray circuit capacitances alone, but with careful construction, and the choice of a suitable triode, it is possible to control oscillation by the use of a small variable condenser in the by-pass position. Replacing C1 by a 15 mμfd. variable condenser is usually satisfactory.

The use of such an oscillating detector is of greatest advantage in the superheterodyne for C.W. reception. An infinite impedance detector, stabilised with a 100 mμfd. by-pass capacitance, gives excellent I.F. selectivity in the detector stage with high quality output, and is also an excellent detector for use immediately following a crystal gate or filter. For C.W. reception, however, it is necessary to heterodyne the signal supplied from the I.F. amplifier to the detector in order that the code characters are made audible. An oscillating detector will perform this duty and save the expense of a separate B.F.O. unit, and the impedance detector can thus be made to perform a wide range of tasks.

A filtering circuit should be connected in the anode line of the valve to prevent any chance of hum and to by-pass any signal voltages at the anode directly to earth.

The R.F. choke, shown in the output circuit, is optional and, if used, should, of course, be effective at the frequency or frequencies covered by the tuned circuits. If it is not used, and C3, the audio coupling condenser, is connected directly to the cathode line, then the by-pass condenser, C2, should also be removed from the circuit, leaving C1 as the sole by-pass condenser.

Components List for the Infinite Impedance Detector, Fig. 1.

L1, C1,	R.F. Tuned circuit, either for direct tuning or the secondary of the last I.F. transformer.
C1, C2,	100 mmfds. R.F. By-pass, or replace C1 by a 15 mmfds. variable condenser for experiment.
C3,	0.1 mfd. 550 v.w. Non-inductive.
C4,	0.5 mfd. 350 v.w. Non-inductive.
R1,	150,000 ohms, $\frac{1}{2}$ watt.
R2,	22,000 " $\frac{1}{2}$ "
R3,	1 meg. variable, Volume control.
VI,	6C5, etc., for 6-volt operation, or 224V, etc., for 4-volt operation.

AUTODYNE FREQUENCY CHANGING

The Autodyne Frequency Changer is one example of an old circuit which is still capable of giving good results from a minimum of components. The circuit consists essentially of a first detector or mixer which also supplies its own local oscillations. One valve, therefore, performs the work of a combined valve such as the triode hexode, or of two separate valves.

The autodyne frequency changer exists in two forms. In the first circuit, shown in Fig. 3, two tuned circuits are arranged round a pentode or R.F. tetrode type valve, the grid circuit being tuned in the usual manner to the

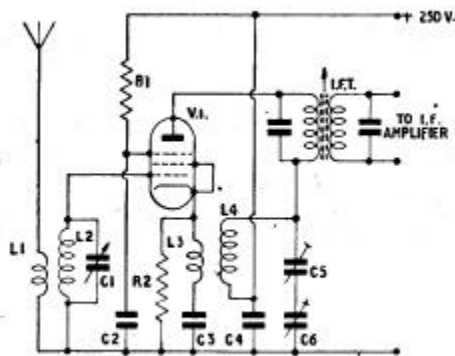

FIG. 3. The Autodyne Frequency Changer.

frequency of the signal it is desired to receive whilst an oscillating circuit is connected into the anode and cathode leads.

If the oscillator voltage is considered as being applied to the grid of the valve, it will be seen that the tuned circuit, L2, C1, is then series-connected between the grid and the oscillator voltage, and this fact has a considerable bearing on the working of the circuit at different frequencies. At broadcast frequencies the tuned signal frequency circuit, L2, C1, will present some impedance to the oscillator voltage, but this impedance will be low since the considerable difference between the signal and intermediate frequencies will result in L2, C1, being detuned to a very great degree so far as the oscillator frequency is concerned. Frequency conversion takes place in the usual way, and provided that the padding condenser C5 is at the correct setting, the two tuned circuits can be adjusted over the medium and long-wave bands by the use of a ganged condenser to give the correct intermediate frequency which is passed on to the I.F. amplifier via the intermediate frequency transformer.

At higher frequencies, however—that is, on the short-wave bands—the percentage difference in frequency between the two tuned circuits is reduced, with the result that as the frequency rises, L2, C1, become less and less detuned from the oscillator frequency. The impedance presented by this tuned circuit to the oscillator voltage thus rises, with the result that a considerable oscillator voltage is set up across L2, C1, which not only tends to cause strong re-radiation, or radiation of an interfering signal, but also reduces the oscillator voltage between the grid and the cathode, the overall efficiency of the frequency converter thus being impaired. The circuit of Fig. 3 should therefore be used only for reception on the medium and long-wave bands, where it is capable of quite satisfactory results. Tests for radiation of interference should always be made, however, and the frequency converter preceded by a simple R.F. isolating stage if any trouble is caused.

The second type of autodyne frequency converter, at one time in considerable use for short and ultra-short-wave reception, was no more than an oscillating detector. By detuning an oscillating detector away from a received signal a heterodyne is caused, the heterodyne frequency at first being in the audio range—the whistle of varying pitch heard as a station is tuned with such a detector—and then, as the frequencies of station and detector further diverge, a heterodyne at radio frequencies. This heterodyne frequency appears as usual in the anode circuit of the detector, and may be passed to an I.F. amplifier via a tuned transformer.

Such a method of frequency conversion must of necessity be inefficient, based as it is upon a deliberate detuning of the detector away from the station to be received, and it will be realised that image reception can be very troublesome with this method, since each signal can be received and converted to the intermediate frequency at two points, one above and one below the station frequency. At the higher frequencies, however, the percentage of detuning is, once again, less; and so the oscillating detector-autodyne can be used, if desired, for reception on the 5 and 10 metre amateur bands with quite fair results. The I.F. must be chosen as a compromise frequency, efficiency on the one hand requiring that it be a low

frequency and the considerations of image reception, where a H.F. stage is used on the other hand requiring a high frequency. This type of autodyne converter was perhaps most used as a receiver converter, feeding into a medium and long-wave receiver to give short-wave reception, and under those conditions the favoured intermediate frequency was of the order of 300 kcs.—that is, the receiver would be tuned to 1,000 metres and the autodyne converter connected into the Aerial and Earth sockets. For ordinary short-wave reception, however, experiments may be conducted using the old style 110 kcs. I.F. transformers, and for ultra-short-wave reception 465 kcs. transformers can be tried.

The oscillating detector type of autodyne frequency converter is shown in Fig. 4, with an output circuit suitable for connecting into the Aerial and

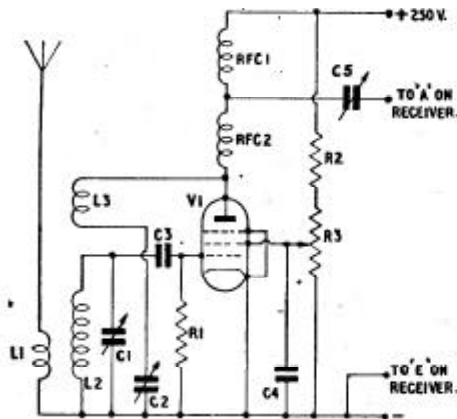

FIG. 4. The Oscillating Detector—Autodyne Converter.

Earth sockets of a medium-long-wave receiver, and in Fig. 5 with I.F. transformer coupling for feeding into an I.F. amplifier.

Using this second type of autodyne, the circuit must, of course, be in a state of oscillation over the whole tuning band and reaction should be controlled by a condenser with fine control given by a variable resistance, in order that the degree of oscillation is under control. This, again, results in radiation from the oscillating detector, and although, on the ultra-short-waves especially, this is much less serious than radiation on the broadcast bands, it is wise to provide an R.F. stage to prevent the radiation and to isolate the aerial load from the detector.

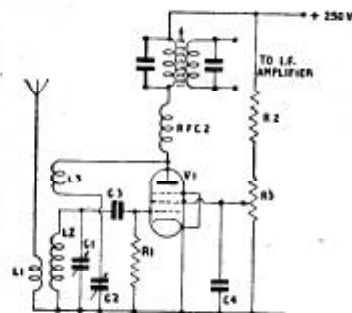

FIG. 5. The Oscillating Detector—Autodyne Frequency Changer with I.F. Feed.

Components List for the Pentode Autodyne Frequency Changer,

Fig. 3.

- | | |
|--|--|
| L1, L2, | Medium and Long-wave Aerial Coils. |
| L3, L4, | Medium and Long-wave Oscillator Coils. |
| C1, C6, | 0.0005 mfd. Ganged tuners. |
| C2, C4, | 0.1 mfd. 350 v.w. Non-inductive. |
| C3, | 0.005 mfd. 350 v.w. Non-inductive. |
| C5, | Padding condenser to suit coils used. |
| (See note re aerial and oscillator coils below.) | |
| R1, | 47,000 ohms, 1 watt, for 6-volt valves. |
| | 22,000 ohms, 1 watt, for 4-volt valves. |
| R2, | 10,000 ohms, ½ watt. |
| I.F.T., | Iron-cored I.F. transformer, 465 kcs. |
| V1, | R.F. tetrode or pentode, VP41, 6C6, etc., etc. |

Aerial and oscillator coils are required to give an I.F. of 465 kcs. Highly recommended are the Wearite P type coils, the PA2 and PA1 being used for medium and long-wave reception respectively in the L1, L2, positions, and the types PO2 and PO1 being used as the corresponding oscillator coils.

The PA1 and PA2 coils should be trimmed with 75 mmfds. maximum adjustable screw-type trimmers, and the PO1 and PO2 coils should be trimmed with 75 and 100 mmfds. maximum trimmers respectively. The padding condensers in the C5 position should be 150 mmfds. maximum for the long-wave band, and 450 mmfds. maximum for the medium-wave band.

Components List for the Autodyne Frequency Changer and Short-wave Converter, Figs. 4 and 5.

- | | |
|-------------|-------------------------------------|
| L1, L2, L3, | Aerial, Tuning and Reaction coils. |
| C1, | Tuning condenser. (See note below.) |
| C2, | 0.0005 mfd. Reaction condenser. |
| C3, | 0.0001 mfd. Silver Mica. |
| C4, | 0.1 mfd. 350 v.w. Non-inductive. |
| C5, | 0.0005 mfd. Midget variable. |

R1,	1 meg., $\frac{1}{2}$ watt.
R2,	56,000 ohms, 1 watt.
R3,	50,000 ohms, variable.
R.F.C.1,	Medium and Long-wave Choke.
R.F.C.2,	Short-wave Choke.
L.F.T.,	Iron-cored I.F. Transformer, 465 kcs., or experimental.

V1, 6K7, 6SK7, 6J7, etc., for 6-volt operation, or SP4B, VP41, etc., for 4-volt operation.

Note.—The values of L1, L2, L3 and C1 will depend on the frequency range to be covered. For 28 and 56 mcs.—10 and 5 metre working—C1 may be 40 mmfd. maximum, such as the Raymatt VC40X, whilst for 5 metres L1 should be 2 turns, L2 should be 9 turns and L3 should be 4 turns of wire all wound to $\frac{1}{4}$ " diameter. L1 and L2 may be of a heavy gauge, 18 S.W.G., with turns separated by their own diameter, with L3 closewound just below L2, using 26 S.W.G. enamelled wire. For 10 metres, L1 should be 3 turns, L2 20 turns, and L3 10 turns, L2 in this instance also being closewound using 18 S.W.G. enamelled wire, the other coils being wound as before.

For the lower frequency amateur bands, C1 should be a 100 mmfd. variable condenser, the coils being wound on $\frac{1}{4}$ " diameter coilforms, the windings being as follows:—

20 metres band—		
L1,	8 turns	26 S.W.G. enam. closewound, $\frac{1}{4}$ " above L2.
L2,	10 "	18 S.W.G. " spaced to $1\frac{1}{2}$ " long.
L3,	5 "	26 S.W.G. " closewound $\frac{1}{4}$ " below L2.
40 metres band—		
L1,	8 turns	26 S.W.G. enam. closewound, $\frac{1}{4}$ " above L2.
L2,	18 "	18 S.W.G. " spaced to $1\frac{1}{2}$ " long.
L3,	9 "	26 S.W.G. " closewound $\frac{1}{4}$ " below L2.
80 metres band—		
L1,	10 turns	26 S.W.G. enam. closewound $\frac{1}{4}$ " above L2.
L2,	32 "	18 S.W.G. " " "
L3,	15 "	26 S.W.G. " " " $\frac{1}{4}$ " below L2.
160 metres band—		
L1,	12 turns	26 S.W.G. enam. closewound $\frac{1}{4}$ " above L2.
L2,	54 "	24 S.W.G. " " "
L3,	20 "	26 S.W.G. " " " $\frac{1}{4}$ " below L2.

VERY HIGH FREQUENCY EQUIPMENT

Whilst superheterodyne reception can give very good results on the ultra-short-waves—or, more properly, the Very High Frequencies—the tuning becomes extremely sharp at 5 metres and, for frequencies above this band, of the order of 60 to 120 mcs., the efficiency of valves used as R.F. amplifiers and frequency changers falls off rapidly. The experimenter who is interested in reception on the 10 and 5 metre bands, and who does not wish to go to the expense of building a specialised superhet for the work, can obtain excellent results from either mains or battery valves in single-valve circuits by using the super-regenerative type of reception.

Theory and practice both show that an oscillating detector is at its most sensitive operating point just as it passes into oscillation, a point at which it is virtually impossible to maintain an ordinary circuit. If, however, by some means the detector circuit can be made to pass in and out of oscillation at a rapid rate, this point of excellent operation will virtually be maintained, and super-regeneration is a method of achieving this object. The super-regenerative circuit enables an ordinary triode valve to give amplifications at very high frequencies of the order of thousands and possibly millions.

Further advantages of the super-regenerator are that the signal is no longer sharply tuned, and whilst this may be slightly troublesome on a crowded band such as the 10-metre band, the ease with which signals are selected and held makes up for the lack of selectivity. The super-regenerator also gives a remarkable degree of what may be called Automatic Gain Control, so that signals of very different strengths are heard at similar audio levels. Interference of the ignition and impulse type is suppressed, and whilst the super-regenerative circuit is characterised by a fairly loud hiss, this hiss either diminishes, or, for a strong station, disappears, whenever a signal is tuned, so that a further advantage appears in that a temporarily unmodulated carrier announces its presence as definitely as does a modulated carrier wave—a point often of importance when searching for V.H.F. signals.

The super-regenerator circuit relies upon two operating frequencies, the first being the fundamental tuned frequency of the main tuning circuit—that is, the signal frequency at which reception is taking place—and the quenching frequency which is a variable frequency with an optimum value for the best results with any circuit. The quenching frequency should be above audio limits, and may become sufficiently high to be classed as a radio frequency. The use of quenching on the original oscillations at the signal frequency cause the super-regenerator to be a fairly strong transmitter of interference, but a good R.F. stage preceding the super-regenerating circuit, and good receiver screening, will reduce this effect should it be troublesome.

The two frequencies may be obtained from a single-valve circuit, or one valve may work at the signal frequency with the quench frequency introduced from a second valve oscillator. The quenching obtained with these two types of circuit varies, but in either case the working is highly satisfactory.

The Flewelling circuit, shown in Fig. 6, is one of the best single-valve circuits. Here the valve oscillates at the signal frequency so vigorously that

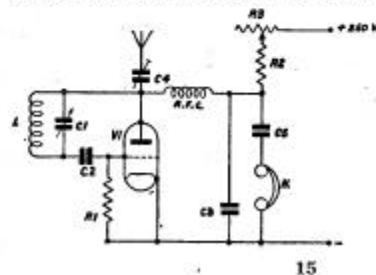

FIG. 6. The Flewelling Super Regenerator.

the grid becomes "blocked"—that is, so negatively charged that oscillations cease while the charge leaks away through the grid leak. This leak, in conjunction with the grid condenser and the condenser from the anode circuit to earth, therefore sets the quenching frequency, and the value of C3 may be varied to give the best results.

The circuit works with complete reliability with mains valves, especially if an Acorn triode is used, but is inclined to be temperamental when tried with battery valves. A modified form of the circuit can be used with the latter, this circuit being as shown in Fig. 7, where the grid leak is made a much greater resistance and gives the grid a positive drive from the H.T. line via the tuned circuit. The writer has used a 1T4 button valve with the circuit shown in Fig. 7 with an H.T. voltage as low as 36 volts, but stronger quench action is obtained with an H.T. of at least 50 volts.

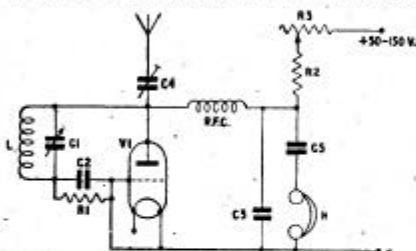

FIG. 7. Adapted Flewelling Circuits.

The super-regenerator may be fed from any aerial, and a long wire aerial, several times the length of the preferred wavelength, is very suitable. Such an aerial gives best results when coupled, not inductively, but capacitively through a small capacitance to the anode of the valve. The condenser used may be of the variable trimmer type, mounted so that adjustment is easy, or a midjet variable condenser may be used.

Since the tuned circuit in the Flewelling super-regenerator has neither side directly connected to earth, an extension spindle must be used as the tuning drive, a spindle length of 3 or 4 inches being ample. Slow-motion drives, however, are not at all necessary, and consequently the receiver does not need a panel. The tuning condenser and variable resistance may be mounted on small insulating sub-panels, the extension spindle thus bringing out the tuning control to the front of the receiver. Perspex is an excellent material for H.F. insulation, and may be drilled and tapped with ease.

Components List for the Flewelling Super-Regenerator and Adapted Circuit, Figs. 6 and 7.

- L, 6-10 metres, 20 turns 18 S.W.G. enam. $\frac{1}{8}$ " diam., closewound.
- L, 4-7 " 9 " 18 S.W.G. " $\frac{1}{8}$ " diam., spaced own diam.
- C1, 40 mmfds. Tuner. Raymart VC40X.
- C2, 0.0001 mfd. Silver Mica.

- C3, 0.002 to 0.006 mfd. Mica.
- C4, 30 mmfds. variable or semi-variable.
- C5, 0.1 mfd. 350 v.w. Non-inductive.
- R1, for Fig. 6, 220,000 ohms, $\frac{1}{2}$ watt.
- R1, for Fig. 7, 2 to 4 megohms, $\frac{1}{2}$ "
- R2, 47,000 " $\frac{1}{2}$ "
- R3, 250,000 ohms variable, regeneration control.
- R.F.C., 60 turns 30 S.W.G. closewound on 1 meg. ceramic resistor as former.
- H, High resistance headphones.
- V1, for Fig. 6, 955, AC2HL, etc., or 6J7, etc., with screens strapped to anode.
- V1, for Fig. 7, HR210, etc., or 1T4, etc., with screen strapped to anode.

An even more satisfactory circuit for battery triodes is shown in Fig. 8. Here C1 acts as a reaction control if made variable, but since variation of this capacitance results in detuning, it is usual to work with a fixed condenser

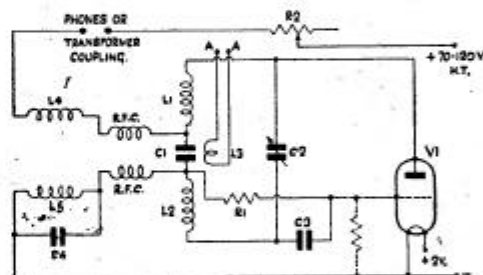

FIG. 8. A Battery Super Regenerator.

in this position, controlling regeneration by means of a variable resistance in the H.T. line. Quenching in this circuit is obtained by means of a pair of quench coils series-connected in the feed lines, isolated for R.F. by small chokes.

The two coils, L1 and L2, must be considered as a single coil so far as R.F. is concerned, and so both coils must be wound in the same direction, and aerial coupling may be made either inductively, a small coil of two or three turns of wire being inserted in the central gap between the two main coils, or else the aerial may be tapped on to the grid coil via a small semi-variable condenser.

The quench coils may be obtained commercially, from Messrs. Eddystone or Messrs. Bulgin, or may be home-made. Each coil should consist of 600

or 700 turns of fine wire, such as 30 or 34 S.W.G. enamelled, and a former may be made up from thick fibre or plywood. Cut three discs 2" in diameter, and another four discs of the material 1" in diameter, and assemble these discs by drilling them each centrally and arranging them on a screw as shown in the diagram of Fig. 9.

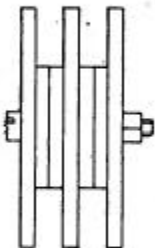

FIG. 9. Quench Coil Former.

If the circuit fails to super-regenerate it is probably only necessary to reverse the connections to one of the quench coils to bring the windings into the proper sense.

The grid leak may be taken to the point shown or directly to the negative filament or "earth" connection, some types of valve preferring one and some the other connection. To use the circuit as a power oscillator for transceiver or "walkie-talkie" operation, it is necessary only to short-circuit the quench coils, and the grid condenser, transferring the negative line connection direct to the grid of the valve through another R.F. choke, constructed in the same manner as the chokes already in circuit. The H.T. current then rises on oscillation instead of falling by the action of self-bias, and a small triode will accept as much as 2 watts anode input. The oscillator responds well to speech modulation introduced into the anode circuit by anode modulation, a battery output pentode fed from a carbon microphone giving sufficient modulation depth. Simple switching enables the pentode to be used as a transformer-coupled audio amplifier for reception, the transformer primary acting as the modulating choke on transmission.

Components List for the Super-Regenerator, Fig. 8.

C1,	0.0005 mfd. Silver Mica.
C2,	60 mmfds. Tuner: Raymart MC60X.
C3,	0.0003 mfd. Silver Mica.
C4,	0.003-0.01 mfd. Quench tuner. Test for best results.
R1,	2.2 meg. ½ watt. Alternative connection shown dotted.
R2,	100,000 ohms variable. Regeneration control.

R.F.C., 60 turns 30 S.W.G. enam. on 1" glass or ebonite rod.

L1=L2, 5 turns 16 S.W.G. ½" diam., turns spaced own diam.

L3, 2 " 16 S.W.G. enam. between L1 and L2.

Coil sizes given are for the 5-metre band and television sound. The layout adopted will cause tuning changes, and slightly larger or smaller coils may be required to suit the receiver construction.

L4=L5, Quench coils. (See text.)

V1, HR210, etc. Use a medium impedance triode.

An extension spindle is necessary for tuning, and the layout must be neat and with short direct wiring.

The super-regenerative receiver does not give good quality sound, distorting or cutting even the higher audio frequencies so that despite its tremendous amplification it is useless for television reception. The quality can be improved, however, by using a separate quench valve, the depth of quench thus being under individual control, and a two-valve circuit is shown in Fig. 10. The design is for battery valves, but mains triodes may be used if desired with no change in components values.

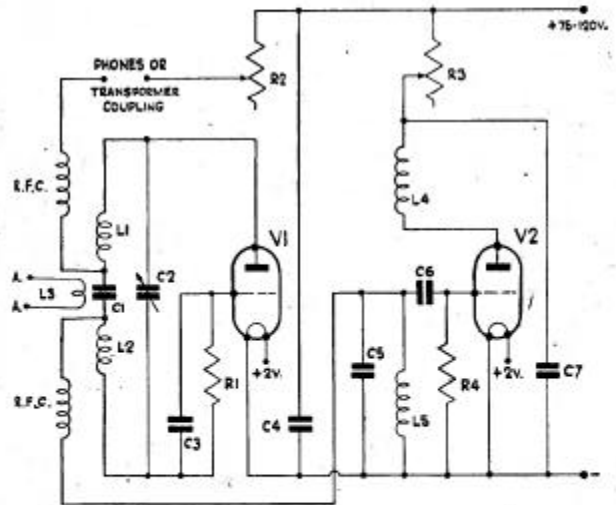

FIG. 10. A Two-valve Super Regenerator.

Components List for the Two-Valve Super-Regenerator, Fig. 10.

C1,	0.0005 mfd. Silver Mica.
C2,	60 mm/ds. Tuner. Raymart MC60X.
C3, C6,	0.0001 mfd. Silver Mica.
C4, C7,	0.5 mfd. Paper.
C5,	0.003-0.01 mfd. Quench tuner. Test for best results.
R1,	2.2 meg. $\frac{1}{2}$ watt.
R2,	100,000 ohms variable. Reaction control.
R3,	100,000 ohms variable. Quench control.
R.F.C.,	60 turns 30 S.W.G. enam. on $\frac{1}{2}$ " diam. glass or ebonite rod.
L1-L2,	5 turns 16 S.W.G. $\frac{1}{2}$ " diam., turns spaced own diam.
L3,	2 turns 16 S.W.G. between L1 and L2.
L4-L5,	Quench coils, as described in text.
Coils sizes given are for the 5-metre band and television sound.	
V1, V2,	HR210, etc., for battery working, or AC2HL, 6J5, etc., for mains operation.

An extension spindle is necessary for tuning.

CHAPTER 2

EXPERIMENTAL CIRCUITS IN AUDIO DESIGN

VOLUME EXPANSION AND COMPRESSION

Both in the broadcasting and recording of sound, especially orchestral music, a degree of volume compression is used in order that the overall amplitude of the audio signal used to modulate the carrier wave or, in recording, to operate the cutting head, shall be maintained within fixed limits. To obtain the best from the reproduced sound, therefore, a volume expanding circuit should be employed to restore the cuts made in the original sound.

Volume compression may be manual or automatic. For example, the compression introduced into a studio broadcast is often manual, the adjustment being made by ear at the control panel, but in recording studios there is, beside the control panel compression, a degree of compression automatically introduced by the use of compressing circuits. It is argued, therefore, that volume expansion is really pointless unless the expanding circuit can be made to have exactly the same expansion factor as the compression factor originally used, but in actual fact an expansion circuit can give extra life and tone to a broadcast programme or reproduced record without reference to the original compression level, and so is well worth time spent in experiment and testing.

Since one circuit can give both compression and expansion of volume, the effect of compression on records which appear to be rather over-recorded can also be tested.

Since volume expansion and compression is limited to an audio amplifier, it may be taken that for expansion the overall gain of the amplifier rises as the input signal voltage rises, and for compression the overall gain of the amplifier falls as the input signal voltage rises. All that is necessary, therefore, is a device which will give rise to a biasing voltage, the biasing voltage rising and falling with the amplitude of the signal. This bias can then be applied to one of the amplifier valves, the valve gain rising or falling with the bias according to the sense in which the control voltage is connected.

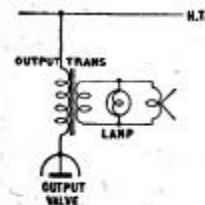

FIG. 11. A Simple Volume Expander.

It is also possible to obtain volume expansion, however, by "waste" methods, and the simplest of these is shown in Fig. 12. A small lamp, connected in parallel with the voice coil and output transformer secondary of the loudspeaker system will pass a percentage of the output which thus will not affect the voice coil, but as the output power rises the current flowing through the lamp also rises. This causes the lamp filament to heat up and thus to increase its resistance, so that the power lost in the lamp is actually reduced and the overall gain of the amplifier apparently rises with a rise in the input signal voltage. The reduction of power lost in the lamp circuit is, of course, a percentage reduction—a large output will, naturally, cause more power to be lost in the lamp than will a small output but the percentage of loss to total power will be smaller.

The time constant, or delay in volume changes, when using any type of expansion or compression circuit must be taken into consideration, and the lamp circuit shown, together with other circuits derived from the same principle, have the disadvantage of a rather long delay time, since a lag exists between the passage of current and the heating of the filament with its consequent resistance change. This makes the lamp circuit unsuitable for use with the "popular" type of music, although the circuit may, in general, be used with classical music.

The simple lamp circuit shown in Fig. 11 can be developed to give control not on the output side of the final transformer but, by the introduction of a resistance into the lamp circuit, control by negative feedback. This type of control utilises the potentials set up across the lamp and resistance circuit, one side of the circuit being earthed. By means of a

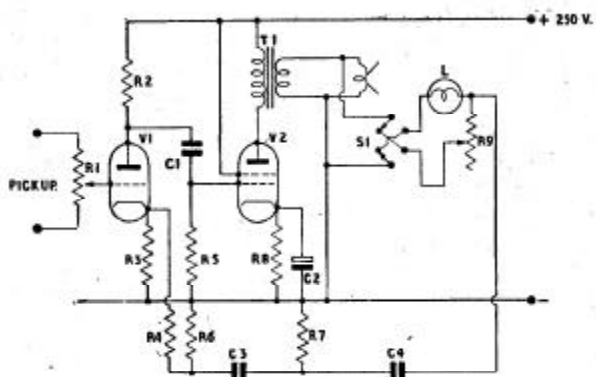

FIG. 12. A Compression-Expansion Amplifier.

simple switching device, feedback can then be taken to an earlier stage in the audio amplifier and either compression or expansion introduced at will.

In Fig. 12 is shown a simple two-stage amplifier using the Pen 45 beam output valve, although other types can also be used.

Experiment with the type of lamp and the resistance value used with the lamp will give varying degrees of feedback and thus of overall control.

Components List for the Compression-Expansion Amplifier, Fig. 12.

R1,	1 meg. variable.	Volume control.
R2,	47,000 ohms,	$\frac{1}{2}$ watt.
R3,	470	" "
R4,	22,000 "	$\frac{1}{2}$ "
R5,	220,000 "	$\frac{1}{2}$ "
R6, R7,	10,000 "	$\frac{1}{2}$ "
R8,	180 "	$\frac{1}{2}$ "
R9,	0-30 ohms, variable, wirewound.	
C1, C3, C4,	0.1 mfd. 350 v.w. Non-inductive.	
C2,	50 mfd. 25 v.w. Electrolytic.	
S1,	D.P.D.T. Compression-Expansion switch.	
T1,	Output transformer, 5 watt, match to 5,200 ohms anode load.	
L,	Lamp. This should be determined experimentally using normal torch and cycle lamp bulbs.	
V1,	AC2HL.	
V2,	Pen 45.	

Switch right for expansion, left for compression. The parallel lamp and resistance circuit will cause a slight mismatch of the loudspeaker voice coil through the transformer to the output valve, so that a slightly lower transformer ratio might be used with good effect.

A more conventional volume expander is shown in Fig. 13 where a diode is provided with a signal which is rectified and used as the control bias in the controlling valve, a pentagrid. The input signal voltage to the circuit

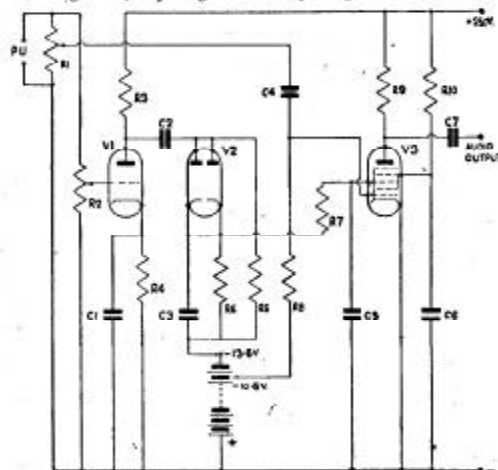

FIG. 13. Volume Expansion Pre-amplifier.

must be small, and so the unit is inserted in the position of a pre-amplifier, being fed directly from the pick-up. A crystal pick-up will usually overload this type of volume expander, and a magnetic pick-up with an output of approximately $\frac{1}{2}$ volt maximum should be used.

A battery is shown supplying the negative voltages required for biasing. Whilst these voltages could be obtained from a potential divider, the battery supply is more easily arranged and there is no likelihood of feedback troubles.

Components List for the Volume Expansion Pre-amplifier, Fig. 13.

R1, R2,	1 meg. variable input controls.
R3, R5, R7, R9,	100,000 ohms, $\frac{1}{2}$ watt.
R4,	10,000 "
R6,	220,000 "
R8,	1 meg. "
R9,	22,000 "

C1, C3, C5, C6,	0.5 mfd. 350 v.w. Non-inductive.
C2,	0.25 mfd. 350 v.w. "
C4,	0.02 mfd. 350 v.w. "
C7,	0.1 mfd. 350 v.w. "
V1,	6CS.
V2,	6H6.
V3,	6L7G or 1612.

Still another volume expansion circuit which has proved popular is a circuit using a variable-mu valve and diode. In this circuit, shown in Fig. 14, a variable bias dependent on the signal input amplitude is applied to the control grid of the variable-mu pentode, the output being taken from the cathode load of this valve, the output impedance varying with the valve characteristic.

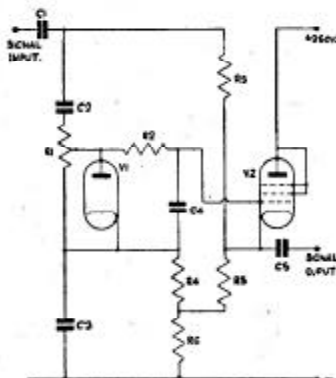

FIG. 14. Volume Expansion Cathode Follower Unit.

The contrast expansion unit may be connected either before or after the first amplifying stage, some amplification being desirable before the signal is passed through this unit.

Components List for the Expansion Unit, Fig. 14.

R1,	100,000 ohms variable, expansion control.
R2, R4,	470,000 " 1/2 watt.
R3, R6,	22,000 " 1/2 "
R5,	330 " 1/2 "
C1, C5,	0.1 mfd. 350 v.w. Non-inductive.
C2, C3, C4,	0.25 mfd. 350 v.w. "
V1,	D1.
V2,	VP4B.

WIDE RANGE TONE CONTROL STAGES

The majority of receivers commercially made have no provision for tone control, and whilst radiograms and record-players are better equipped in this respect, the control range often leaves much to be desired.

Tone controls with wide ranges can be incorporated in most equipment without trouble, however, and the following circuits are all interesting from the experimental point of view, and can be installed between the stages of a simple two-stage amplifier for comparison.

The simplest tone control giving both treble and bass attenuation is shown in Fig. 15. The treble attenuator by-passes the higher audio fre-

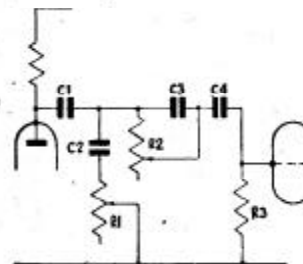

FIG. 15. A Simple Tone Control.

quencies to earth via a resistance-capacitance filter, whilst the bass attenuator passes the middle and high frequencies with ease whilst filtering the bass. Both controls are variable and controlled by variable resistances.

Components List for the Simple Tone Control, Fig. 15.

C1, C4,	0.1 mfd. 350 v.w. Non-inductive.
C2,	0.005 mfd. 350 v.w. "
C3,	0.001 mfd. 350 v.w. "
R1,	0.25 meg. variable, treble control.
R2,	0.25 meg. variable, bass control.
R3,	220,000 ohms, 1/2 watt.

A master volume control is easily added to this tone control circuit, and the writer has found this arrangement of particular value for feeding into the phase splitter of a paraphase or push-pull output stage. The volume control should appear as near as possible to the final stage in order that noise introduced by the preceding valves is reduced in ratio with the signal volume, whilst a master volume control is needed if the amplifier includes mixed inputs from a pick-up and microphone, or two pick-ups.

In Fig. 16 the whole tone and volume control unit is shown feeding into a typical phase splitting circuit, the phase splitter valve being practically any 4 or 6 volt triode.

Should the unit be required to feed into a single-ended or normal stage rather than a phase splitter, it is only necessary to omit C5, R4 and R7 (R6 may also be by-passed by a 25 mfd. 25-volt condenser if a little extra

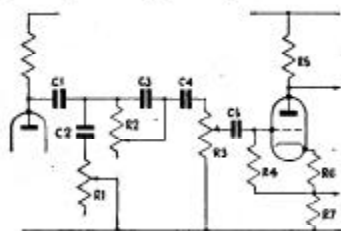

FIG. 16. A Tone and Volume Control Unit.

gain is needed), taking the connection from the moving arm of the volume control direct to the valve grid. C5 and R4 are necessary in the phase splitter stage to isolate the grid of the valve from earth.

Components List for the Tone and Volume Control Unit, Fig. 16.

C1, C4,	0.1 mfd. 350 v.w. Non-inductive.
C2,	0.005 mfd. 350 v.w. "
C3,	0.001 mfd. 350 v.w. "
C5,	0.02 mfd. 350 v.w. "
R1,	0.25 meg. variable, treble control.
R2,	0.25 meg. variable, bass control.
R3,	1 meg. Volume control.
R4,	1 meg. $\frac{1}{2}$ watt.
R5, R7,	47,000 ohms, $\frac{1}{2}$ "
R6,	1,500 " $\frac{1}{2}$ "

This tone control, in common with many other types of control, attenuates the bass and treble frequencies, whereas in many cases a boost at either treble or bass frequencies, or both, is required, the middle frequencies being left almost unaffected. To obtain a boost at the ends of the frequency range a special circuit is always necessary, and in some cases choke coils are used. The use of chokes, however, often gives rise to troubles, the most likely of which is hum pick-up, and a valve circuit to give boosting of variable degrees in both the bass and treble frequencies is shown in Fig. 17.

The valve is, in effect, shunted by a frequency discriminating network, and the following stages are coupled into this network in a variable manner, the tone control being effected by variable phase opposition, the outputs of anode and cathode of the valve being connected in opposition.

Such a control stage should not be relied upon to give great signal amplification, although there will, of course, be some degree of gain. Suppressing the middle frequencies of the audio range, however, always gives the impression of a considerable loss of volume—one advantage of the tone

control of Figs. 15 and 16 is that the apparent volume loss for change of tone is very small—and so the control stage of Fig. 17 should be used as a pick-up input stage before a complete amplifier, rather than be used as an amplifier stage proper.

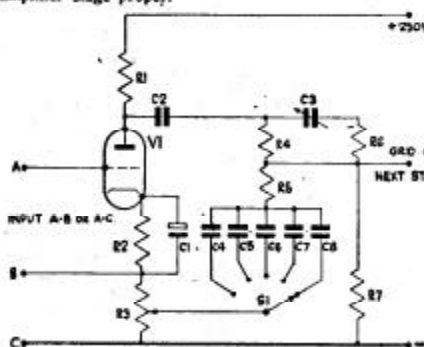

FIG. 17. Treble and Bass Boosting Stage.

The cathode control can be used as a tone compensated volume control for some settings of the tone controls, to offset the apparent change in tone obtained with some straight volume controls where decreasing volume apparently gives a tonal change which is really caused by the varying sensitivity of the ear for different sound intensity levels.

The input to this tone control stage can be applied in two different ways, either between the grid and earth or between the grid and cathode, the three input lines being indicated in the figure. Applying the input between grid and earth means that negative feedback over the cathode load will be introduced into the circuit, so that the already low stage gain is further reduced. Applying the input between grid and cathode will avoid this effect, but at the same time will mean that the pick-up or other component supplying the input signal will not have one connection directly earthed as is usually the case. This means that there will be some chance of hum introduction, but if the metal case of the pick-up, microphone, etc., is earthed, this should give ample shielding to the interior circuits.

Components List of Treble and Bass Boosting Stage, Fig. 17.

R1,	47,000 ohms, $\frac{1}{2}$ watt.
R2,	1,000 " $\frac{1}{2}$ "
R3,	10,000 " variable
R4,	220,000 " $\frac{1}{2}$ watt.
R5, R6,	75,000 " $\frac{1}{2}$ "
R7,	1 meg. $\frac{1}{2}$ "
C1,	50 mfd. 25 v.w. Electrolytic.
C2, C8,	0.5 mfd. 350 v.w. Non-inductive.
C3,	0.0005 mfd. Variable.

C4,	0.01 mfd. 350 v.w. Non-inductive.
C5,	0.015 mfd. 350 v.w. "
C6,	0.03 mfd. 350 v.w. "
C7,	0.05 mfd. 350 v.w. "
S1,	S.P. 5-way selector switch.
V1,	MHLA, etc., or 6C5, etc.

The circuit shown was developed by J. E. Varrall and first published in the *Wireless World*, by whose permission it is included in this Manual.

For the experimenter who wishes to test the effects of a choke tone control, the circuit of Fig. 18 has many points of interest. Here, again, the stage gain is much reduced by the use of the control, but the overall effect is a bass boost with a lesser treble boost, the middle frequencies being successively attenuated as the moving arm of the control approaches the anode connection. The values of the inductance and condenser filter circuit as shown centre the main attenuation about 1,000 cycles, the conventional frequency for this type of control. The following stage should have a high

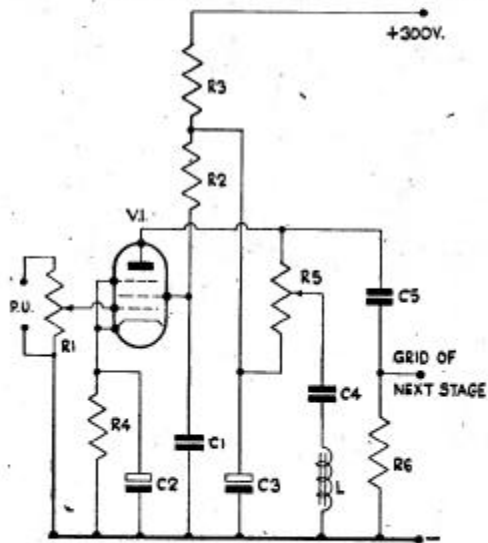

Fig. 18. Middle Frequency Attenuator Stage.

resistance grid leak, and the control valve may be used as the input valve for an amplifier for record reproduction, the tone control curve being well suited for gramophone work.

The inductance must be very well screened and oriented with regard to minimisation of hum pick-up from mains transformers, etc.

The control should be worked from a pentode valve, not a triode, and American pentodes with high resistance loads give best results. Such valves as the 6J7, 6C6, etc., are recommended.

Components List for the Middle Frequency Attenuator Stage.

R1,	1 meg. variable. Input volume control.
R2,	1.5 meg. $\frac{1}{2}$ watt.
R3,	47,000 ohms, $\frac{1}{2}$ "
R4,	1,500 " $\frac{1}{2}$ "
R5,	0.25 meg. variable. Tone control.
R6,	1 meg. $\frac{1}{2}$ watt.
C1,	0.1 mfd. 350 v.w. Non-inductive.
C2,	25 mfd. 25 v.w. Electrolytic.
C3,	8 mfd. 350 v.w. "
C4,	0.01 mfd. 350 v.w. Non-inductive.
C5,	0.02 mfd. 350 v.w. "
L,	2.5 Henrys.
V1,	6C6, 6J7, etc.

Fig. 18.

CATHODE FOLLOWER OUTPUT STAGES

The cathode follower output stage offers excellent opportunities to the experimenter who is also interested in high quality sound reproduction. This type of output stage has the primary of the output transformer connected between the valve cathode and the earth line, instead of in the anode line, and whilst the circuit requires special considerations, especially in so far as grid drive is concerned, there are several advantages attached to such an output arrangement.

In the first place, it has already been explained that a cathode follower circuit usually results in practically 100% negative feedback over the stage, so that distortion in the cathode follower stage itself is eliminated for all practical purposes. This also means, of course, that no useful amplification is gained from the stage—indeed, there is a loss so that the output of the stage compared with the input to the stage shows a gain of less than unity—but the negative feedback means that the grid drive can be increased. The chief advantage, however, so far as the cathode follower output stage is concerned, lies in the great increase in loudspeaker damping which it provides.

Loudspeaker damping is of considerable importance in the reproduction of sound. A loudspeaker, by reason of its construction, has several damping effects, the damping being the absorption effect which prevents resonance or

"hangover" vibrations of the cone. Generally speaking, the higher the damping factor of the whole output circuit can be made, the better is the quality of the reproduction, especially in the bass frequencies, high damping factors giving a crisp quality difficult to describe but very apparent to the ear. The use of a triode output valve assists the damping factor over the output stage for the reason that, despite the mechanical damping due to the fastening of the cone edge to the frame, the stiffness of the central spider and the air pressure on the speaker cone, a valuable damping effect is obtained through the moving coil itself. The moving coil is suspended in a strong magnetic field, and with any such device a short circuit across the coil will result in heavy damping whilst an infinite resistance across the coil ends will result in very low damping. The effect may be seen in an unshunted millimeter, where connecting the terminals together will prevent the pointer from swinging across the scale with movement of the instrument; although removing the short circuit, and thus opening the moving coil circuit, will leave the pointer free to swing with every movement given to the instrument.

The damping factor introduced into the loudspeaker stage by the valve itself is given by the relationship

$$DF = \frac{RL}{rp}$$

where DF is the damping factor, RL is the load resistance as given by the valve manufacturers' lists, and rp is the valve's A.C. anode impedance. Some examples taken from manufacturers' lists give revealing figures and indicate that a triode gives a much greater damping factor than a pentode or beam tetrode output valve.

For a PX4,

$$DF = \frac{4,000}{830} \text{ or } 4.82.$$

For a P15/250,

$$DF = \frac{2,300}{660} \text{ or } 3.48.$$

For a 6F6 pentode, however,

$$DF = \frac{7,000}{8,000} \text{ or } 0.87$$

and for a 6L6 beam power output valve,

$$DF = \frac{2,500}{22,500} \text{ or } 0.11.$$

The damping factor, therefore, is reduced to a very considerable extent in a pentode or beam power stage. A cathode follower stage has a very low output impedance, and so a beam tetrode or pentode used in a cathode follower circuit has its damping factor improved by a large amount.

The circuit for a cathode follower output stage is shown in Fig. 19, together with the driving valve, and several points require attention. In

the first place it has been shown in the case of the impedance detector that the output voltage across the cathode load of a cathode follower is in series with the input voltage at the grid, so that in the case of Fig. 19 the grid input voltage swing must be increased above the swing which would normally be applied for ordinary operation of the valve. This means that the penultimate stage, the driver, must supply a greater output voltage, such an increase being obtainable either by stepping up the signal voltage already to hand by the use of a transformer, or by increasing the H.T. supply voltage to the valve anode through the feeder stage load resistance. The use of a transformer is obviously the simpler method and so the feeder is coupled to the output stage via a parallel-coupled transformer with a ratio of 5 : 1.

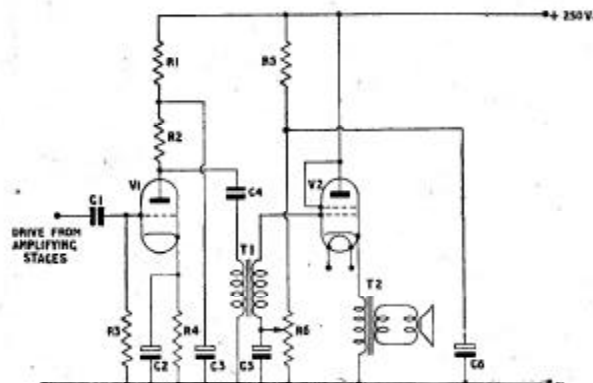

FIG. 19. A Cathode Follower Output Stage.

For experimental purposes any inter-valve transformer to hand might be used in this position, but a good component will naturally improve results since its frequency response curve will be so much more favourable than will be that of a cheap instrument.

A medium impedance triode should be used to feed into a transformer coupling, the MH4 or 354V or similar types being suitable for 4-volt heater valves, with the 6C5 a suitable 6-volt heater valve.

The choice of the output valve depends on several factors, and many types may be tested. An AC2 Pen has given excellent results with this type of circuit, but several pentodes and tetrodes, triode-connected, work well. The requirements of a good valve are a high slope and, with triode connections, if the valve is a tetrode or beam pentode, a not too high internal impedance.

The ordinary bias on the valve cathode must be maintained, and here again a complication arises since the output transformer primary is now connected in place of the bias resistance and the bias applied to the valve will depend on the total cathode current and the D.C. resistance of the transformer primary winding. Where the primary winding is fairly low, the bias applied may be approximately correct, but a high resistance winding will impose too great a bias on the cathode—the cathode, it must be remembered, will be at a too positive potential above earth. To counteract this effect a positive potential may be applied to the grid of the valve, and this potential may be obtained either from a small battery with its negative pole connected to the earth line, or from a voltage-divider connected as shown. If, however, the transformer has a very low resistance primary, as may well be the case with a heavy-duty component with stout windings, the bias applied will probably be too low and the grid will then need a negative bias, obtained once again from a battery, connected this time with its positive pole to earth.

Remember that the matching or load impedance presented by the transformer does not affect the bias potential set up on the cathode. It is the D.C. resistance of the winding which must be taken into account.

The most satisfactory method of measuring the bias, and of adjusting the potential applied to the grid, whether positive or negative, is to measure the total current flowing through the output transformer primary with no signal input, adjusting the grid biasing potential until the current is approximately correct.

The output impedance of the valve will change under these conditions, if the valve used is a tetrode or pentode connected as a triode, and the value to be used is no longer that given by the makers' valve tables. To a certain degree the cathode follower will automatically adjust its output impedance to match to any load, so that extreme care over matching is not necessary, but a serious mis-match will lead to distortion and serious power loss, just as does a mis-match in a more conventionally connected circuit, so that some endeavour to provide the correct matching must be made. The output impedance may be taken as twice the valve's anode impedance under the new triode-connected conditions, and the ratio of the output transformer windings will then be calculated from the usual formula

$$R = \sqrt{\frac{\text{output impedance}}{\text{voice coil impedance}}}$$

For the AC2 Pen the output impedance may be taken as 5,000 ohms, so that to match a 3-ohm voice coil speaker to this figure the ratio of the primary and secondary windings will be

$$R = \sqrt{\frac{5,000}{3}}$$

$$= \sqrt{1,666} \text{ or } 40 : 1 \text{ approximately.}$$

The cathode current of this valve should be adjusted to 40 mAs. by adjusting the bias arrangements.

The 6L6 may be tried as a cathode follower output stage, although its output will be below that of the AC2 Pen. Connected as a triode, the 6L6

requires 20 volts bias, which may be adjusted by setting the total cathode current again to 40 mAs. The output impedance may be taken, for the 6L6, as 3,400 ohms when triode-connected.

The 6F6, triode-connected, gives rather a small output but is worth testing. The total cathode current should be set to 30 mAs. or a little more, and the output impedance should be taken as 5,000 ohms.

Provided that sufficient grid swing can be provided from the feeder and transformer coupling, an illuminating experiment is to work with a PX4 first as a conventional output stage with the output transformer anode-connected, and then as a cathode follower output stage. The transformer matching must be changed to some degree, being reduced to a 1,600 to 1,700 ohm load for cathode-connection instead of the 4,000 ohm load used for anode-connection, but the bias requirements will remain the same, the cathode current for cathode follower output working being set, by bias adjustment, to 50 mAs.

The PX4 or any similar triode with a directly-heated filament acting as the cathode must, of course, be supplied with a separate heater winding, this winding having a centre tap. The output transformer is connected between this centre tap and earth just as is a bias resistance, and it is practically a necessity to feed the heater of any valve used as a cathode follower output stage from a separate, unearthed, heater winding. The cathode will be at high potentials above earth as the output current swings, so that should the valve heater be earthed the potential difference between cathode and heater might easily break down the insulation between them, ruining the valve.

Components List for the Cathode Follower Output Stage, Fig. 19.

C1,	0.1 mfd. 350 v.w.	Non-inductive.
C2, C5,	50 mfd. 50 v.w.	Electrolytic.
C3, C6,	8 mfd. 350 v.w.	"
C4,	4 mfd. 350 v.w.	Paper.
R1,	33,000 ohms,	$\frac{1}{2}$ watt.
R2,	47,000 "	$\frac{1}{2}$ "
R3,	470,000 "	$\frac{1}{2}$ "
R4,	1,000 "	$\frac{1}{2}$ " or to suit valve.
R5,	220,000 "	$\frac{1}{2}$ "
R6,	50,000 "	variable, bias set.
T1,	5 : 1 inter-valve transformer.	
T2,	Output transformer.	
V1, V2,	(As in text.)	

CHAPTER 3

EXPERIMENTS IN TELEVISION RECEPTION

As is well known, the reception of the television programmes from the Alexandra Palace transmitter is dependent on locality and distance from the station, so that television experiments are, in the main, of interest only to those fortunate enough to live within the service area of the transmitter.

With reports of regular and good reception coming from the Channel Islands and Devon, however, and rumours of a service extension in the near future, the would-be televiewer should at least test the possibilities of his own particular locality with respect to the present transmissions.

The size of a television set with reference to the number of stages required between aerial and cathode ray tube depends on the signal strength at the aerial and the tube sensitivity, but if a signal can be received which is clear and steady, without fading, a set can be built to give good programme value. The exploration, therefore, may be carried out by a sound receiver tuned in turn to both vision and sound transmissions.

If a super-regenerative receiver is used to make the first field strength tests, it must be remembered that the gain of such a set is extremely high, and whilst the two transmissions may be heard distinctly on a simple one-valve circuit, a television receiver proper might require a multiplicity of stages to give a good picture. The reason for this is that each stage of a television receiver, whether the circuit is of the T.R.F. or superhet type, has a very limited gain. Each stage is called upon to pass a very wide band of frequencies, the band-width, for really high quality, being 5 or 6 mcs. and at the same time the very high frequencies used make the input impedance of the valve appear very low, so that the circuit is working at a low level of efficiency. Then, again, no advantage can be taken of regeneration, since each stage must have a linear phase response, or as nearly linear as possible—the writer tested a regenerative circuit for television reception on the standard black cross transmission, the result being that the horizontal arm of the cross only appeared on the screen—and in order to keep the band-width of the succeeding circuit broad, each stage can have only a relatively low resistance or impedance load, this again causing loss of amplification.

The audible signal obtained from a television transmission is a low purr or hum, the frame-synchronising pulses, with an over-tone of a high-pitched note at above 10,000 cycles, this being caused by the line-synchronising pulses. The picture content frequencies are, in most cases, above the limits of audibility. The super-regenerative receiver will show a strong carrier with only low modulation since the synchronising pulses modulate the carrier only to a shallow extent.

Presuming that it is found that signal strength is sufficient to warrant reception experiments, one promising line of work would appear to be the adaptation of a cathode ray oscilloscope for television work. The writer has examined pictures on his own apparatus (described fully with constructional details in Bernard's "Television Constructors' Manual" No. 59), using screens with diameters as small as 3" and picture detail is still surprisingly clear and distinct with such small tubes. Green fluorescent tubes are perfectly suitable for television reception, although the blue type of oscilloscope tube is worse than useless, the picture brilliancy being low; but, apart from this, the tube having a slow die-away fluorescent characteristic. Hard tubes, of course, must be used, and gas-focused tubes are also useless.

The internal change which must be made to the oscilloscope to make it suitable for picture reception is to provide a modulation input to the tube

"grid" or shield, isolating this electrode from the potential divider resistance chain and also providing the cathode with a self-biasing resistance. The usual oscilloscope will have the cathode connected to point A in Fig. 20, the grid being connected to the arm of a potentiometer, point B. If desired, the potentiometer can be removed from circuit, its place being taken by a fixed resistance, the value of which is that of the total resistance of the potentiometer, this procedure leaving the fixing hole free for a new variable resistance, R1, which is connected directly in the cathode line. The new resistance R1 must have a highly insulated moving arm in some oscilloscopes, and the experimenter will hardly need reminding that all these adaptations must be made with extreme care.

The tube is now provided with self bias, the biasing resistance having a higher value than might be expected because the tube cathode current is so low.

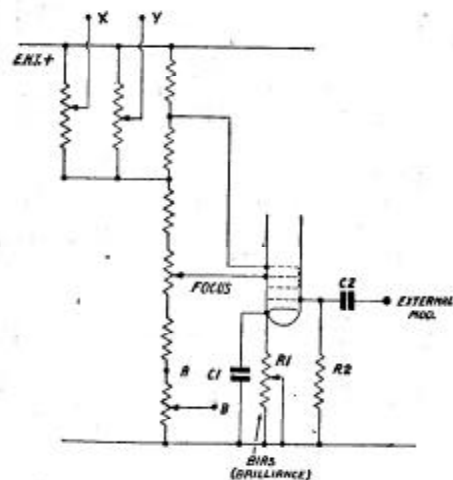

FIG. 20. Connections for Grid Modulation of the Oscilloscope.

The tube grid is now isolated from the potential divider and connected to the negative line via a high resistance. The grid, although still receiving negative bias, is open to accept modulation voltages. The grid should be connected to a new terminal or binding post marked "External Mod" through a high-voltage condenser. Room should be found on the oscilloscope panel or case for such a terminal, since the provision of a modulated grid input is of considerable value in many oscilloscope applications.

Components List for the Oscilloscope Adaption Circuit, Fig. 20.

- | | |
|-----|--|
| R1, | 0.5 meg. variable, self-bias control.
(Brilliance.) |
| R2, | 2 megohm resistor, $\frac{1}{4}$ watt. |
| C1, | 0.5 mfd, 250-volt working. Non-inductive. |
| C2, | 0.1 mfd. 1,000 or 2,000 volts working.
(The working voltage be at least 20% greater than the cathode ray tube E.H.T. supply.) |

We now have a cathode ray tube with its power supplies conveniently isolated from the receiver power supply, with focus and brilliancy controls, with a modulated grid, and, moreover, furnished with one of the two necessary time-bases. The internal time-base should be used as the line time-base, set at a frequency of 10,125 cycles, a frequency which it should be possible to obtain from a good instrument since the usual limiting frequency of a good oscilloscope time-base is 20 kcs.

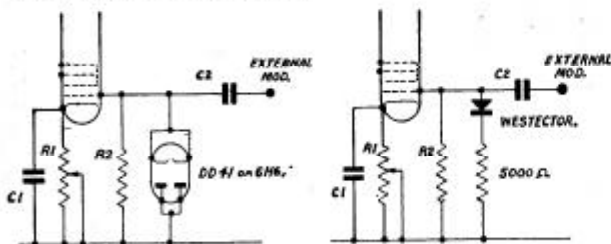

FIG. 21. Two Methods of D.C. Restoration.

It now remains to provide the receiver proper, a synchronisation splitter with sync. feeds to the oscilloscope time-base and the external time-base, and a frame time-base operating at 50 cycles, this gear to work from a separate power pack.

The receiver may take one of several different forms, the signal strength again dictating the requirements. For a locality within a few miles of the transmitter, two R.F. stages—a diode detector and a video amplifier—are quite sufficient, whilst a weak signal will require a superhet circuit, the I.F. stages running at an intermediate frequency of approximately 13 mcs. since I.F. stages can give rather more gain than R.F. stages.

The time-base, however, can be standardised, and is shown in Fig. 22. The circuit uses the new Transatron-Miller Integrator circuit, and sufficient sweep is given, with very linear characteristics, to give full frame deflection on a 6" diameter tube with a time-base H.T. of no more than 250 volts.

The internal time-base of the oscilloscope is connected in the usual manner to the X plates of the tube, the new time-base being connected to the Y plates, and there must obviously be a common connection between the external and internal apparatus.

The time-base chassis should be connected to the oscilloscope chassis and the output to the tube's Y plate—do not use the oscilloscope's built-in amplifier for this purpose. The time-base shown in Fig. 22 has a negative-going saw tooth and it may be that the picture produced will be upside down. The output line must be connected to each Y plate in turn to discover the correct sense.

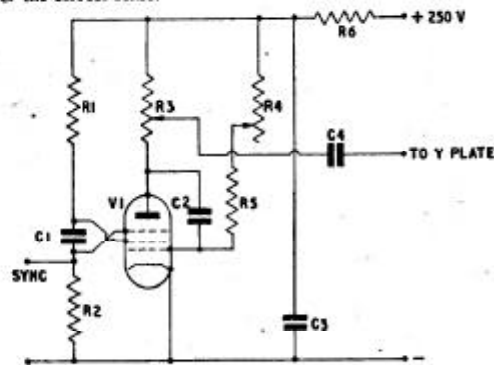

FIG. 22. Frame Timebase Oscillator.

The other connections between the oscilloscope and the external apparatus are for synchronisation and modulation.

The receiver chassis should be joined to the oscilloscope chassis and the receiver's line sync. terminal joined to the scope's synchronisation terminal. This leaves only the modulation connection to arrange. The receiver has a cathode follower output circuit and where the home constructor has built his own power supply unit for the cathode ray tube he should arrange to earth the negative supply line of the E.H.T., the output of the receiver may then be connected directly to the cathode ray tube's grid.

However, where a standard oscilloscope is used with the positive line earthed, the unit must be connected through a condenser as shown in Fig. 20. This means that for the best results D.C. restoration should be applied to the tube's grid, but during the experimental stage this can be omitted and a good picture still obtained, in fact, many commercial television sets of the pre-war period had no D.C. restoration. The circuit at Fig. 21 shows how restoration may be applied. Either a Westector with 5,000 ohms in series may be placed across R.2. (the resistor is merely to limit the current through the Westector) or a diode valve may be used without a

resistor, the valve gives better results, but since the electrodes will be at full E.H.T. voltage to chassis it is necessary the diode heater winding on the transformer be well insulated. Suitable valves are the DD41 for 4 volt circuits and the 6H6 for 6 volts.

The choice of valves for all positions in the receiver and external gear is wide, but excellent results have been obtained with 4-volt heater types, using SP41 television pentodes in the receiving stages, and accordingly this type is shown in the diagrams. The experimenter will have no difficulty, however, in substituting 6-volt heater types if desired, using such types as the EF50 or Z62.

The time-base circuit as shown will work with practically any pentode, but preferred types are the EF39 for 6-volt operation and the VP41 for 4-volt working. The same types also operate well in the sync. separator stage.

Components List for the Frame Time-base Circuit, Fig. 22.

R1,	100,000 ohms, $\frac{1}{2}$ watt.
R2,	750,000 " $\frac{1}{2}$ "
R3,	0.25 meg. Variable. Sweep amplitude control.
R4,	2 meg. variable. Sweep frequency control.
R5,	6 meg., $\frac{1}{2}$ watt.
R6,	4,700 ohms, $\frac{1}{2}$ watt.
C1,	0.01 mfd. 350 v.w. Non-inductive.
C2,	0.005 mfd. Mica.
C3,	8 mfd. 350 v.w. Electrolytic.
C4,	0.1 mfd., 1,000 v.w. Oil-filled.
VI,	EF39 for 6-volt working, or VP41 for 4-volt working.

Whether a T.R.F. or superhet circuit is used for the receiver, the detector, video amplifier, D.C. restorer and sync. separating circuits will follow the same design, and this section of the receiver is shown in Fig. 23.

The tuned inductance feeding into the diode detector will depend on the preceding circuit. For T.R.F. reception the coil will be tuned to 45 mcs, whilst for a superhet the coil will be a single winding I.F. " transformer."

The diode detector and D.C. restoring diode are combined in one valve since a DD41 is used (a 6H6 for 6-volt circuits), and the choke coupling between the diode and video amplifier will also be suited to the carrier or intermediate frequency according to whether straight or superhet arrangements are used.

The video amplifier is a simple stage with a percentage of negative feedback over the cathode resistance and a normal anode load of low resistance. It is usual to provide a choke in the anode line to correct for high frequency losses, but when a small tube is to be used, with as simple receiving circuits as possible, experiment shows that the inclusion of such a choke gives no visible improvement in picture quality.

The triode following the video amplifier and D.C. restorer is necessary to reverse the phase of the signal at the tube grid in order that the sync. separator is supplied with a negative going signal if the signal applied to

the tube is considered as positive going. The triode is not required to give high amplification so that a fairly high cathode resistance is used.

The sync. separator, connected as shown, gives negatively-phased sync. pulses which are correct for the frame time-base as given in the diagram of Fig. 22. Unfortunately, some types of time-base require a positively going pulse for synchronisation, and if such a time-base is included in the oscilloscope there may be a little trouble in obtaining correct synchronisation. Once again, however, experiments have shown that many types of time-base are remarkably adaptable to incorrectly phased sync. pulses, and in all probability the sync. pulse as supplied to the oscilloscope will give good working.

There are several simpler methods of connecting the sync. separator to the video amplifier and thus dispensing with the triode phase reverser, but in almost all these simpler circuits the video amplifier then becomes a more complicated stage, requiring stabilisation of the screen voltage, and the use of the triode circuit is well worth while.

There is a second advantage in using the triode, however. The modulated tube grid may be connected directly to the anode of the video amplifier via a suitable condenser, just as is the grid of the triode, but in the event of a condenser break down the tube grid would be driven positive by 200 volts or so, the cathode ray tube thus being damaged. The method of feeding the tube from the triode cathode load is not only perfectly safe under all conditions, it also reduces shunt capacitances across which higher frequency signal detail can be lost, and at the same time enables a long lead to be used for the receiver-tube connection, whilst no distortion can mar the picture.

The method of feed shown here was first described by W. T. Cocking.

Components for Detector and Output Stages of the Television Receiver,

Fig. 23.

C1,	0.001 mfd. Micg.
C2,	20 mmfda. Silver Mica.
C3,	0.01 mfd. 350 v.w. Non-inductive.
C4, C5, C6, C7,	0.1 mfd. 350 v.w. "
C8,	0.05 mfd. 350 v.w. "
C9,	0.0001 mfd. Mica.
C10,	0.001 mfd. 1,000 v.w.
R1, R2,	4,700 ohms, $\frac{1}{2}$ watt.
R3,	47 " $\frac{1}{2}$ "
R4,	1 meg. " $\frac{1}{2}$ "
R5,	15,000 " $\frac{1}{2}$ "
R6, R9, R11,	10,000 " $\frac{1}{2}$ "
R7, R8,	100,000 " $\frac{1}{2}$ "
R10,	22,000 " $\frac{1}{2}$ "
R12,	51,000 " $\frac{1}{2}$ "
R13,	30,000 " $\frac{1}{2}$ "

Ch. R.F. Choke effective at either 45 or 10-15 mcs. For 45 mcs, wind 50 turns of 30 S.W.G. enam. on $\frac{1}{2}$ " diam. former. For 10-15 mcs, use Wearite PA6 coil.

V1, V3, combined, DD41.
 V2, SP41.
 V4, 354V.
 V5, VP41.

Take one side of each heater to earth.

THE RECEIVER TUNED CIRCUITS.

Whether T.R.F. or superheterodyne reception is used, it is advisable, for home construction, to use the simplest tuned circuits possible, and accordingly both types of receiver are shown with single-winding permeability-tuned coils. Commercial sets generally use coupled transformers between stages, but since it is necessary to construct the coils in the home workshop a single winding is to be preferred.

The T.R.F. circuit is shown in Fig. 24, the detector being duplicated since it is also shown in Fig. 23. The method of coupling is made clear, however, and it should be remembered that the detector is shown twice in the separate diagrams when constructing the receiver.

It must also be remembered that in the T.R.F. receiver each stage is working at a very high frequency, so that wiring and component placement are highly important. Leads must be direct and short, and all the earthed connections from each stage, such as by-pass condensers, coil earths, etc., should be taken to one point on the chassis for each stage, the best method being to mount a soldering tag under one retaining screw of each valve-holder, all the earth connections for each stage being taken to that stage's tag.

Once again, one side of each heater should be directly earthed, the connection being omitted from the drawings for the sake of clarity.

By the use of small condensers and $\frac{1}{2}$ -watt resistors it is possible to group all the components of each stage under their respective valve-holder, thus reducing the chance of interaction.

Two R.F. amplifying stages are shown in the T.R.F. circuit of Fig. 24, and it will be found that two stages can be run with no trace of interaction or feedback if the supply line voltage does not rise above the 250-volt level. Three stages, however, are much more prone to feedback and instability troubles, and a third stage should only be added if necessary. No contrast control is shown in the diagram; for home-constructed apparatus and a small tube where, generally speaking, maximum contrast is required, the control is unnecessary, and its omission leaves the circuit simple and inexpensive to build.

Some experiment will be necessary to obtain the best results from the coils. These are wound on paxolin formers or, if at hand, ceramic formers with an outside diameter of $\frac{1}{2}$ ". The wire used should be 18 S.W.G. and the coils are tuned, not by condensers, which would peak the response curve, but by movable or plunger cores. It is quite possible to wind coils tuned to the

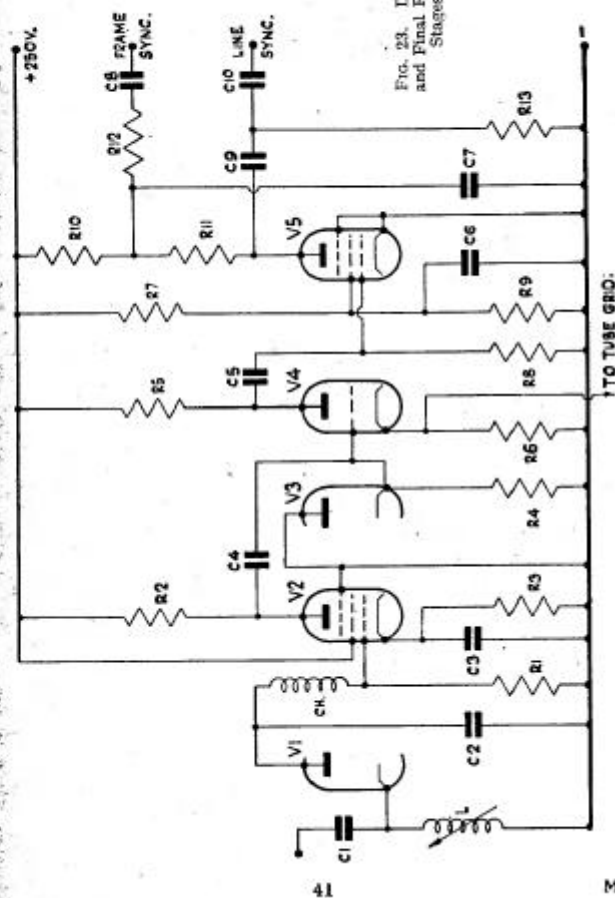

transmission frequency without the use of cores, but a simple plunger system enables the tuning to be set with much more ease.

The plungers should be of the iron dust type, iron-cored I.F. transformers being one source of suitable cores, which are mounted on long 4 B.A. brass bolts and arranged to screw down into the centre of the coil. If iron dust cores are unobtainable then brass cylindrical plungers may be used in their place, a stock of suitable brass rod being the surplus sawn off ends of long spindled volume controls. If iron cores are used, L1 should have 5½ turns, and L2 and L3 6 turns each, but if brass plungers are used, L1 should have 6½ turns and L2 and L3 7 turns each.

The aerial may be coupled to the receiver by using a separate coil of 2 turns overwound on L1, but better energy transference seems to be given by tapping the feeder on to the coil and to earth, as is shown in Fig. 24. Near to the transmitter a simple dipole mounted inside the roof gives ample pick-up, but at greater distances an open-air dipole with reflector is almost essential. Tap L1 1½ turns up.

It will be seen that the receiver, whether T.R.F. or superhet, does not combine the functions of receiving the sound signal as well as the picture signal in the first stages as is normal with commercial superhet receivers. This combination of the two frequencies leads to difficulties which are best avoided by the home constructor, and the sound signal can be received by a simple receiver working from its own aerial. The author has used a super regenerative receiver for this purpose, and whilst such a receiver, if allowed to act normally, would blot out the picture signal by interference, reducing the anode voltage of the detector until super regeneration ceases still gives excellent gain, and the sound may then be fed to an ordinary two or three valve amplifier to give very good quality.

FIG. 24. Two R.F. Stage Television Receiver (use with Fig. 23).

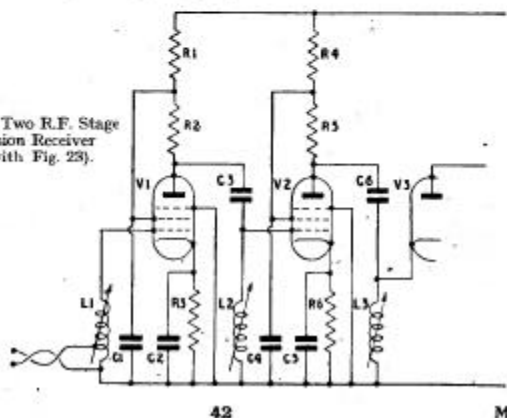

Components List for the 2 R.F. Stage Receiver, Fig. 24.

R1, R4,	1,000	ohms,	½ watt.
R2, R5,	10,000	"	½ "
R3, R6,	220	"	½ "
C1, C2, C4, C5,	0.01 mfd.	350 v.w.	Non-inductive.
C3, C6,	0.001 mfd.		Mica.
L1, L2, L3,			See Text.
V1, V2,			SP41.

The superhet tuned circuit, shown in Fig. 25, will also be found a rather simpler circuit than the ordinary broadcast frequency type. Once again single coils are used in both the R.F. and I.F. stages with the final adjustments made by permeability tuning in each case. An R.F. amplifying stage precedes the frequency-changer in order that the signal to noise ratio of the first stages shall be assisted, and condenser tuning is used for the oscillator tuned circuit. For an I.F. of about 13 mcs. the oscillator must therefore tune either to 32 or 58 mcs., the signal frequency being 45 mcs. Considerations of oscillator harmonics shows that 58 mcs. is the better frequency, and the I.F. of 13 mcs. is chosen in order that the I.F. stages shall be working on a frequency outside ordinarily used channels so that the injection of outside interference on to the intermediate frequency is unlikely.

The experimenter will wish to wind his own coils—in any case, single winding I.F. coils of this type are in short supply—and L4, L5 and L6 of Fig. 25 may be wound, as are the R.F. coils, on paxolin formers of ½" outside diameter. There will, of course, be some stray capacitance to bring the coils into tune, even though no tuning condensers are used—the coils will have a self-capacitance and the valves present an input capacitance whilst the couplings between stages also exert a tuning effect. With these capacitances duly allowed for, the I.F. coils require 33 turns of 24 S.W.G. on the ½" former, the turns being spaced evenly over a winding length of 1½". Iron dust cores should again be mounted to screw in and out of the former along its central axis.

L3, the oscillator coil, need not be former wound but can be a self-supporting helix of 8 turns of 18 S.W.G., ½" diameter, wired directly across the oscillator tuning condenser, C8, which has a maximum capacitance of 40 mmfd. Since neither side of this condenser is earthed, it must be mounted on an insulating bracket, and provided with an extension spindle for adjustment. The oscillator tuning assembly should for preference be completely screened in an aluminium can.

L1 and L2, both tuned to the original signal frequency, should be constructed according to the details given for L1 and L2 in Fig. 24.

In both Fig. 24 and Fig. 25, it will be seen that the R.F. stages and I.F. stages respectively are identically similar. The stages in each receiver can therefore be duplicated should it be desirable to experiment with a greater number of stages than those shown.

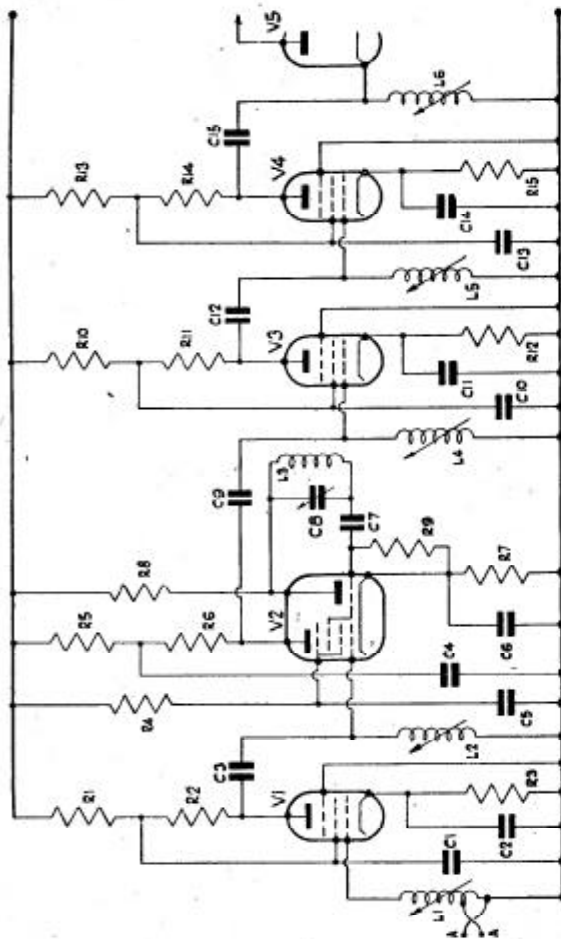

FIG. 25. Superbet Television Receiver (use with Fig. 23).

44

M

Components List for the Superbet Television Receiver, Fig. 25.

R1, R5, R10, R13,	1,000	ohms,	$\frac{1}{2}$	watt.
R2,	10,000	"	$\frac{1}{2}$	"
R3, R7,	220	"	$\frac{1}{2}$	"
R4,	22,000	"	$\frac{1}{2}$	"
R6,	2,200	"	$\frac{1}{2}$	"
R8, R9,	51,000	"	$\frac{1}{2}$	"
R11, R14,	6,200	"	$\frac{1}{2}$	"
R12, R15,	150	"	$\frac{1}{2}$	"
C1, C2, C4, C5,				
C6, C10, C11,				
C13, C14,	0.01	mfd.	350	v.w. Non-inductive.
C3, C9, C12, C15,	0.001	mfd.		Mica.
C7,	50	mmfds.		Silver Mica.
C8,	40	mmfds.		variable. Raymart VC40X.
V1, V3, V4,	SP41.			
V2,	ACTH1.			
L1, L2, L3, L4, L5, L6,				(See Text.)

The receiver, whether of the T.R.F. or superhet type, may be tested on sound before coupling the units together. An input set at 45 mcs. and supplied from a signal generator can be passed through the receiver, a pair of headphones being connected across the cathode load resistance of the triode output stage, the headphone circuit having a 0.1 mfd. condenser in series with one lead. The receiver is then lined up for this input, and then coupled to the oscilloscope for further testing on a vision signal.

The connections between the receiver and oscilloscope have already been explained. To recapitulate, they are:

- (1) Receiver chassis to oscilloscope chassis.
- (2) Triode stage cathode output to oscilloscope modulation terminal.
- (3) Frame sync. to external time-base. (The time-base may be mounted on the receiver chassis and fed from the receiver power pack.)
- (4) Line sync. to oscilloscope internal time-base sync. socket.
- (5) External frame time-base to Y plate of tube.

The power pack used to supply the receiver and time-base should be of conventional design, and capable of giving at least 100 mAs. at 250 volts, with choke and double condenser smoothing. The mains transformer should have good insulation between all windings and frame.

The home constructor is warned that the E.H.T. voltage in most oscilloscopes is in the order of 1,000 volts (sufficient to kill the unwary experimenter) and great care should be taken when building and adjusting this apparatus.

45

M

CHAPTER 4

EXPERIMENTS IN AMATEUR TRANSMISSION

It should be noted that the experiments and gear described in this chapter may be carried out or used only by licensed amateur transmitters, except where the experiments are concerned only with the reception of signals.

CHANGING CRYSTAL FREQUENCY

The amateur who is still in the process of setting up his station may find, on occasion, that a change in frequency within the band on which he is operating may be necessary or desirable. His frequency may be subject to strong QRM or his crystal, used for working on bands other than that containing the fundamental frequency, may double into the wrong portion of the harmonic band. The station with a collection of crystals can easily remedy such occurrences, but the amateur with one or two crystals often has need of a method of changing the crystal frequency by a small amount.

The results obtained from the various methods suggested will depend wholly upon the actual crystal, since different crystals respond to similar treatment in widely varying ways.

A crystal may be held between two electrodes which, by means of sprung mountings, grip the crystal with a slight pressure. The actual pressure employed will have a slight effect on the crystal frequency, and it is possible to take advantage of this fact by making a slight alteration to the mounting springing. Frequency variation thus obtained is very small, but it may be sufficient to clear the transmitter from interference on an adjacent frequency. The crystal, however, may be provided with a different holder, one in which the crystal rests flat on a heavy block of brass or copper, the top electrode being fitted on an adjusting screw so that it may be made to approach the crystal without actually touching its upper surface.

When the gap between crystal and electrode is sufficiently small the crystal will operate with practically no reduction in its power output—in any case, the crystal oscillator should be called upon to supply as little power as possible in the interests of stability—whilst variations in the spacing of the upper electrode will then give a certain degree of frequency variation, probably of the order of 5 kcs. An X or a Y cut crystal operated in such a holder may show a tendency to "jump" to a new frequency when the crystal-electrode spacing is changed, whilst an AT cut crystal will show a steady frequency change with spacing. This behaviour of the X and Y cut types of crystal also occurs with change of temperature, and whilst there is the chance that the "jump" to the new frequency may place the carrier in a desired spot, it is an undesirable characteristic on the whole, and should be avoided, since there is the chance of the sudden change in frequency during a transmission should the crystal temperature rise suddenly or should the crystal-electrode spacing be accidentally altered.

Greater changes of frequency may be obtained by silvering the crystal, this method giving a reduction in frequency. The amount by which the

frequency alters appears to vary with the crystal, for crystals for 14 mcs. operation can give a frequency deviation of 10 or even 20 kcs. for a single coating of silver, whilst a lower frequency crystal, for the 1.75 mcs. band, for example, may require several coatings to give such a wide frequency change. Since the lower frequency crystals are thicker, it would appear therefore that the frequency deviation per silver coating varies as the ratio of the thicknesses of the crystal and the silver layer, the latter, of course, being extremely thin.

The silvering process is simple and takes little time, once the solutions are prepared, and it is advised that the crystal frequency shall be checked after each silvering process.

Commence by cleaning the crystal with carbon tetrachloride in the usual manner and, when thoroughly dried, wash well in distilled water. Note, also, that all solutions must be made up with distilled water, and that tap water must not be used, since there will then be heavy precipitations of the various salts contained in ordinary mains water.

After the initial cleansing the crystal must be handled with tweezers for each operation.

From the distilled water bath transfer the crystal to a $\frac{1}{2}$ % solution of tin muriate, SnCl_2 , using 1 gramme of muriate to 200 c.c. of distilled water. Immerse the crystal in this solution for 5 minutes and then wash well once again in distilled water, discarding the old solution, which should be used only once, before the first silvering operation.

The silvering solutions are prepared from the following solutions:

No. 1.

A. Caustic Soda stick (NaOH),	1.13 grammes.
Distilled water.	180 c.c.
B. Silver Nitrate, pure (AgNO_3)	1.13 grammes.
Ammonia (NH_4OH).	120 c.c.

Add A to B, which produces a cloudy solution, and add further ammonia very slowly drop by drop, shaking the vessel, to clear the solution. Very little ammonia will be required—a further 2 or 3 c.c.

No. 2:

A. Distilled water,	23.5 c.c.
Sulphuric acid, pure, H_2SO_4 ,	2 c.c.

Add the acid to the water in a gentle trickle, stirring well.

B. Cane Sugar,	18 grammes.
Distilled water.	100 c.c.

Heat B till boiling, and add 2.25 c.c. of A. Continue to boil for 15 minutes, and filter the solution for use.

To 20 c.c. of solution No. 1 add 2 c.c. of solution No. 2. The resulting solution will show a colour change as silver commences to deposit. It is necessary to hold the crystal in the dish so that the silvering solution may reach both sides of the crystal, and the solution should be poured into the dish when it has reached an amber colour, the silvering process being allowed to continue until the solution is muddy and coloured brown.

The crystal should then be washed in distilled water, allowed to dry and, after the edges have been cleaned, tested for frequency. Further silvering can be carried out on the first coat by mixing fresh batches of 20 c.c. of No. 1 and 2 c.c. of No. 2 solutions, a fresh mix being used for each successive silvering with distilled water baths in between coatings.

Faulty silvering, over-silvering, etc., can be cleaned from the crystal by the use of dilute nitric acid, the crystal being dipped into an acid concentration just strong enough to dissolve the silver, and then quickly washed in several changes of water.

The dishes and flasks used for the solutions, and which will have a silver coating if used to hold the final bath, may also be cleaned with nitric acid.

FIELD INTENSITY METERS

A field intensity meter should be built and operated by any amateur who uses a beam or rotating aerial, in order that the aerial radiation pattern may be checked and the correct direction of radiation maintained.

The simplest type of intensity meter gives readings on the scale of a moving coil instrument, the instrument deflection being proportional to the field strength at the measuring point, due to the aerial and transmitter under test. In a more comprehensive meter the scale of the instrument may be calibrated in terms of microvolts per metre, but for amateur use this is unnecessary, and is a difficult operation from the point of view of obtaining a standard comparison meter.

The simplest type of intensity meter contains no tuned circuit so that it is limited to one task, but the inclusion of a tuned circuit will render the meter more sensitive, and will also enable it to be used as a frequency meter, whilst providing a headphone jack will allow the intensity meter, tuned or untuned, to be used as a 'phone monitor.

The simplest field intensity meter circuit is shown in Fig. 26, where a short rod aerial feeds into a simple rectifier-indicator system. The rectifier shown is a button type valve connected as a diode, although ordinary triode battery valves, diode-connected, may also be used. A crystal detector of the latest germanium enclosed type will replace the diode and obviate the need for an L.T. battery and switch, but these crystals, which will operate up to extremely high frequencies, are in short supply.

The headphone jack is of the closed circuit type, so that with the headphones withdrawn the instrument works directly from the rectifier.

A sensitive instrument should be used, and whilst a 1mA. full-scale instrument will give results a 50 microamp. movement will improve sensitivity and give higher readings more easily observed. Almost any type of calibration will serve, since the field strength readings are almost always comparative. For observations over a period of time a testing point at a suitable distance from the aerial should be marked, the field strength readings being taken at this point whenever a check is to be made. For the best results the meter should be supported at the correct height—an aerial designed to give a local signal should have a high radiation angle, whilst a DX aerial should have a low radiation angle—but provided that the meter

is always used at the same point the readings obtained will still give an indication of a change in conditions in the transmitter-aerial system with a change in the values indicated by the meter.

The field intensity meter is more often used to tune an aerial to maximum efficiency, however, or for plotting the horizontal pattern of the aerial. To tune an aerial, or to match feeders to a radiating wire for maximum efficiency, the intensity meter should be placed in a position where a readable indication is obtained, the position of the meter lying along the main radiation path of the aerial. Modifications in aerial length or feeder matching, with the same aerial input power at the transmitter, will thus be translated into terms of pointer deflection on the meter, and it will be clearly indicated whether the adjustments carried out have improved the aerial efficiency or not.

To obtain the radiation pattern of a fixed directional aerial, it is necessary to mark or observe a circular path completely round the aerial array at a distance as far away as possible where a readable scale indication is still obtained. The readings should be made with an unmodulated or steadily modulated signal fed to the aerial, the field intensity meter being carried round the circle and a reading taken at every ten degrees. The readings should be plotted against compass direction and may then be transferred to a circular graph on a convenient scale, when the points, connected, will give an indication of the relative directional output of the aerial in arbitrary units as an actual picture.

The rod aerial used with the field intensity meter should be adjusted by trial to a suitable length to give a good deflection with the aerial and transmitter with which the meter is to be used. The rod aerial on the meter should, in general, have the same polarisation as the main aerial, a vertical rod being used with a vertical aerial and a horizontal rod with a horizontal aerial.

In the simplest type of intensity meter, as shown in Fig. 26, a metal plate in the base of the meter case will act as a counterpoise and give an increase in sensitivity.

In the second circuit, shown in Fig. 27, the rod aerial feeds into a tuned circuit, this tuned circuit being coupled inductively into the indicator circuit

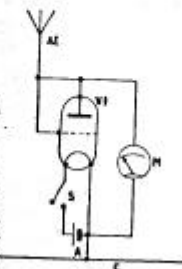

FIG. 26. Simple Field Intensity Meter.

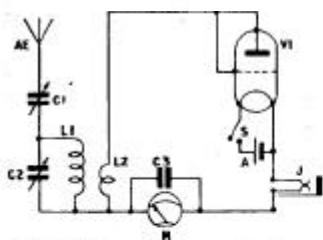

FIG. 27. Field Intensity and Frequency Meter.

so that loading, and thus error in frequency determination, is light, and a sharp resonance point is obtained. Here again the diode connected triode may be replaced by a crystal detector of the germanium type.

In each case the field intensity meter should be built into a metal case, the circuit of Fig. 27 being especially rigidly constructed so that there is no chance of a loose connection or movable component upsetting the calibration. In this model the coils should be made on pin based formers so that the inductances are plugged into a holder, since a range-switch with coils mounted internally in the case would make the meter too bulky for easy portability.

Components List for the Simple Intensity Meter, Fig. 26.

V1,	1G4, 1H4, 30, etc.
S,	S.P.S.T. On-Off switch.
Ae,	Rod aerial.
M,	0.50 microamps, or sensitivities up to 0.1mA.
A,	1.5 volt cell.
C,	Counterpoise earth, copper plate in meter base.

Components List for the Intensity and Frequency Meter, Fig. 27.

C1,	30 mmfd. adjustable trimmer.
C2,	160 mmfd. Wuer. Raymart VC160X.
C3,	0.001 mfd. Mlca.
V1,	1G4, 1H4, 30, etc.
M,	0.1mA.
J,	Headphone jack, closed circuit type.
Ae,	Rod aerial.
A,	1.5 volt cell.
S,	S.P.S.T. On-Off. Coil Data.

5 and 10 metre bands:—

- L1, 3 turns. 18 S.W.G. enam. spaced over 1".
- L2, 2 " 26 S.W.G. enam. closewound 1/4" below L1.

20 and 40 metre bands:—

- L1, 12 turns. 18 S.W.G. enam. spaced over 1".
- L2, 6 " 26 S.W.G. enam. closewound 1/4" below L1.

80 and 160 metre bands:—

- L1, 45 turns. 24 S.W.G. enam. closewound.
- L2, 15 " 26 S.W.G. enam. closewound 1/4" below L1.

All coil sets should be wound on 1 1/2" diameter coil formers, such as the Eddystone 537, which may be plugged into an Eddystone 964 coilbase.

The experimenter who requires a calibrated intensity meter will find interest in the circuit of Fig. 28, especially since the meter contains, in V2, a true D.C. amplifier, to which is applied the potential across the self-biasing resistor of V1, which thus acts as a cathode follower.

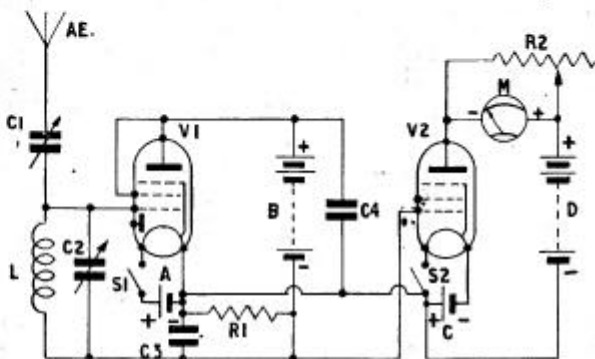

FIG. 28. Field Intensity and Frequency Meter with Decibel Calibration.

A slight disadvantage of this method of working is that the circuit, like many D.C. amplifying circuits, requires separate H.T. and L.T. supplies for each valve, but since low voltages and very small currents are all that are required, layer built batteries can be used. Against this disadvantage can be weighed the advantage of the possibility of applying a direct decibel calibration to an ordinary 100 division 0.1mA. scale with cardinal points at 0, 0.2, 0.4, 0.6, 0.8 and 1mA.

The decibel calibrations range from 0 to 25 decibels, and there is an overlap at each end of the scale. Owing to the method of working, the instrument with no signal input is at nearly the full scale deflection, the application of an R.F. signal causing the reading to fall; 0 decibels thus appears at nearly the full scale reading, the whole scale arc not being used since the decibel calibration loses its linear characteristic at very low signal strengths.

The decibel readings are added to the existing 0-1mA. scale readings at the following points:

0 decibels,	0.9 mA.
plus 5 decibels,	0.72 mA.
plus 10 decibels,	0.54 mA.
plus 15 decibels,	0.35 mA.
plus 20 decibels,	0.18 mA.
plus 25 decibels,	0.04 mA.

To use the intensity meter, switch on the main switch, S1, S2, and with no signal input adjust the instrument reading, by means of R2, to give full scale deflection. With the signal applied to the rod aerial, set the meter in such a position (together with adjustments of C1) that the meter reading falls to 0 decibels. Aerial adjustments or similar work will then show an increase in the decibel reading as signal strength increases. If both falls and rises in signal strength are to be measured, set the instrument, as before, to full scale deflection and then position the meter so that, with signal applied, the new reading is 10 decibels. Fluctuations in signal strength both above and below this level can then be read.

Components List for the Field Intensity and Frequency Meter, Fig. 28.

C1,	30 mmfds. adjustable trimmer.
C2,	160 mmfds. tuner. Raymart VC160X.
C3, C4,	0.0005 mfd. Mica.
R1,	10 megohms. $\frac{1}{2}$ watt.
R2,	1,000 ohms variable, meter zero set.
V1,	1S5.
V2,	1T4.
M,	0.1mA.
Ae,	Rod aerial.
A, C,	1.5 volt cells.
B,	22.5 volt battery.
D,	45 volt battery.
S1, S2, combined,	D.P.S.T. On-Off switch.
L, as L1 in Fig. 27.	

When the meters of the two circuits of Figs. 27 and 28 are to be used as frequency meters, the tuning condenser should be fitted with a good slow motion drive which must be calibrated in terms of frequency, this calibration being carried out against a reliable signal generator, with good output.

Both generator and meter should have a rod aerial, and be placed in close proximity so that sufficient power is picked up by the meter to give an indication on the instrument or, if headphone output is provided, to give an aural indication. Before the calibration is actually made the rod aerial attached to the meter should be tested for loading effect. If too large an aerial is used, the tuned circuit of the meter will be detuned when either the aerial is removed or the aerial condenser, C1, is varied. In this case the meter should be calibrated in terms of frequency with no aerial fitted, since

for the majority of tests requiring frequency measurement the frequency meter will be beside or near the transmitter and will require no aerial. When the meter is required to measure field intensity the aerial can then be plugged into a socket, when the frequency calibrations will be slightly incorrect.

Keeping the aerial small, however, will minimise the detuning effect until the error will be of no consequence.

THE ABSORPTION CONDENSER MICROPHONE

Whilst the condenser microphone gives excellent quality on speech and is used to a considerable extent in amateur transmission, it is troublesome both to feed and pre-amplify. In a conventional circuit the condenser microphone requires a charging potential which, being applied to the microphone electrode coupled via a capacitance to the grid, must be supplied either from a battery or from a power pack with excellent smoothing, whilst it is almost essential to use battery or D.C. operated valves in the pre-amplifier. By using the absorption circuit, however, in which the capacitance of the microphone controls the frequency of a low-power, low frequency oscillator, the charging potential is rendered unnecessary, an A.C. operated valve may be used and a relatively very high amplification is obtained from a single stage.

The circuit, a modification of an old idea which is still not too well known, is shown in Fig. 28. The condenser microphone serves to tune the grid coil of an oscillator in whose anode line is a second tuned circuit set slightly off resonance, the exact degree of mistuning being determined experimentally. Since the stage acts as an electron coupled oscillator, the frequency of the first tuned circuit is stable, and is not "pulled" by the second or anode tuned circuit. When sound waves impinge on the microphone, however, its changing capacitance gives variations in the grid frequency so that varying amounts of power are absorbed by the anode circuit as the grid frequency approaches or recedes towards or away from the anode resonant point. This in turn causes considerable excursions of anode current fluctuating with the sound frequency, so that audio voltages are set up across the secondary of the anode line transformer.

Obviously an operating frequency must be chosen that is well away from any amateur band, and the circuit has been found to work excellently with the coils wound for a frequency of 6 mcs. A frequency approaching the transmitter frequency will cause trouble by heterodyne interference. The actual coil windings will depend on the condenser microphone used, but as a basis for experiment both grid and anode coil may consist of 30 turns of 22 S.W.G. enamelled wire closewound on a $1\frac{1}{2}$ " diameter former, the cathode tap on the grid coil being chosen to give steady and stable oscillation. The coil is best made with one or two tappings brought out for easy experiment, the tappings being made at the 3rd, 6th, 9th, and 12th turn from the grounded end.

Practically any pentode may be used for the oscillator valve in Fig. 29, the anode and screen voltages being kept as low as is consistent with good

operation. The transformer used to couple the audio output into further amplifying and modulating stages will depend on the type of following stages used, and may be a step-up transformer of the ordinary intervalve kind or a step-down transformer feeding into a line.

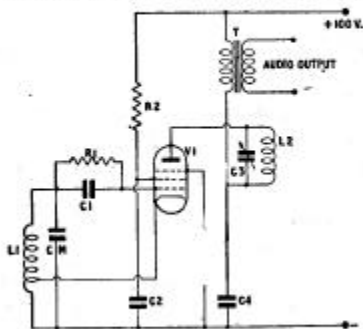

FIG. 29. The Absorption Condenser Microphone Pre-amplifier.

Components for the Absorption Condenser Microphone Pre-amplifier, Fig. 29.

L1, L2,	(See Text.)
C1,	Condenser Microphone.
C2,	0.0003 mfd. Mica.
C3,	0.001 mfd. Mica.
C4,	40 mmfd. tuner. Raymart VC40X.
R1,	0.0001 mfd. Mica.
R2,	47,000 ohms, ½ watt.
T,	10,000 " ½ "
V1,	Interstage transformer.
	6J7, SP41, etc.

CHAPTER 5

EXPERIMENTAL GEAR FOR THE TEST-BENCH

THE ISOCHROMETER

The Isochrometer, or Zero Beat Indicator, is of especial interest to the worker who is engaged in building and calibrating such gear as signal generators, frequency meters and apparatus calibrated in terms of frequency. Calibration of signal generators and allied instruments generally presents considerable difficulty to the worker with only ordinary facilities, and is usually performed by using a standard commercial signal generator against the generator to be calibrated, both the generators feeding into a radio receiver. The standard generator is set to a desired frequency, the instru-

ment under test is tuned until a beat note is heard in the receiver and, when the tuning of the second generator is such that the beat note is inaudible, showing that the two generators are tuned to the same frequency, that frequency may be entered as a point on the dial of the generator undergoing calibration.

In actual fact, however, the two generators may not be exactly at the same frequency. The ear is insensitive to frequencies below perhaps 30 or 20 cycles per second, whilst it is possible that the receiver used as an indicator has a deliberately restricted loudspeaker which is very insensitive to frequencies of 50 cycles and below. Even without these disadvantages, visual indication of zero beat frequency would be of greater value, and this can be provided by the Isochrometer circuit shown in Fig. 30.

The two frequencies to be compared are fed each via an R.F. amplifier to a detector valve. Anode bend detection is used so that the valve passes only a low current and a milliammeter can be connected in the bias line. An R.F. signal applied to this detector causes a variation in the cathode current, and thus gives an indication on the milliammeter. A pair of headphones in the detector anode circuit give a rough zero beat indication, and when the limit of audibility is reached the milliammeter takes over as the indicating device.

It will be found that as the beat frequency between the two signals approaches zero the instrument pointer will swing to either side of the position it has taken up (for the 6C5 the instrument reading will be approximately 0.2mA. with no signal applied) in time with the beat, reaching a steady state at a new reading when the beat frequency is exactly in tune and the two generators whose frequencies are being compared are set at exactly the same frequency.

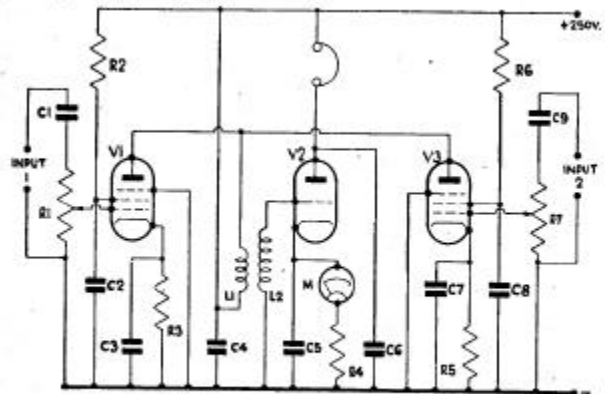

FIG. 30. The Isochrometer.

At the commencement of the test the two inputs should be adjusted to give roughly equal outputs from the R.F. amplifiers by means of the input controls.

It will be seen that the H.F. transformer coupling the two input R.F. amplifying pentodes to the triode detector has an untuned secondary. By this means the coil attached to the detecting circuit has a fairly wide passband, so that ordinary tuning coils or plug-in coils may be used to cover most frequencies.

The apparatus feeding into the two input circuits must be very loosely coupled to the isochrometer, to avoid any chance of changing the frequency by loading. In general a capacitance of a few mmfds. between the un-earthed input terminal and the output socket of the generator or other gear under test will suffice, the chassis of the isochrometer being connected in each case to the chassis of the external apparatus. If A.C./D.C. type power packs are in use especial care must be taken to avoid crossed mains leads when making these chassis connections.

Components Lists for the Isochrometer, Fig. 30.

R1, R7,	250,000 ohms, variable.	Input controls.
R2, R6,	330,000 "	$\frac{1}{2}$ watt.
R3, R5,	1,500 "	$\frac{1}{2}$ "
R4,	82,000 "	$\frac{1}{2}$ "
C1, C9,	0.005 mfd. 350 v.w.	Non-inductive.
C2, C3, C7, C8,	0.1 mfd. 350 v.w.	"
C4, C5,	0.5 mfd. 350 v.w.	"
C6,	0.001 mfd. Mica.	"
V1, V3,	6J7 or VP41.	
V2,	6C5 or MHL4.	

When using 4-volt valves, R2 and R6 may be reduced to 22,000 ohms with R3 and R5 reduced to 330 ohms.

M,	0.1 mA.
L1, L2,	
Long-waves,	Wearite PHF1.
Medium-waves,	Wearite PHF2 and PHF7.
Short-waves,	Wearite PHF6, PHF5, PHF3 and PHF4.

ALL-FREQUENCY OSCILLATORS

An oscillator which will give an audio-modulated output over a very wide band of frequencies, so that the output from the oscillator, supplied to a receiver, will give a test over both long and medium waves simply by tuning the receiver round the dial will obviously be of great use on the test-bench. A multivibrator working on an audio frequency will give such a signal, since a pair of valves, connected as shown in Fig. 31, form an unstable oscillating circuit with a distorted wave-form which contains a very great number of harmonics. If the multivibrator is set to work at a fundamental frequency of 500 cycles, an audio note, the harmonics will form an R.F. carrier modulated at 500 cycles with the carrier peaks separated by only the same

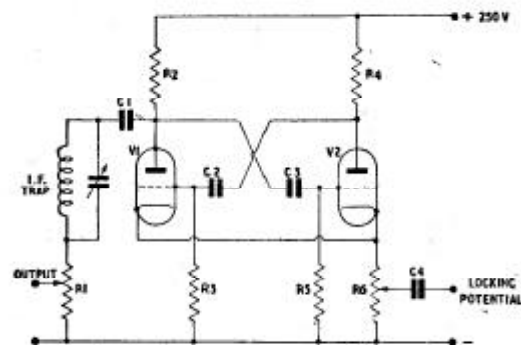

FIG. 31. The Multivibrator.

amount, so that to all intents and purposes a continuous signal is obtained which, with careful construction and the elimination of losses, can extend to frequencies as high as 10 mcs. It has been found that this type of signal is particularly useful for the padding of superhet circuits, the oscillator trimming being performed at the usual high frequency end of the band, using a signal generator, the receiver then being tuned to any convenient point at the low frequency end of the band. The padder is simply adjusted until maximum output from the multivibrator signal is obtained, and the trimming checked.

When the multivibrator is used in this way, its output at frequencies around 460 kcs. should be reduced by a filtering circuit in order that direct I.F. interference shall not render the padding response less direct.

This, however, is far from being the limit of usefulness of the multivibrator. Since it is an unstable circuit its fundamental frequency can be locked to another frequency injected into the circuit at any one of several points, and the locking frequency can be either a harmonic or sub-harmonic of the multivibrator fundamental. Thus, the 500 cycle multivibrator frequency may be locked to the mains frequency of 50 cycles simply by feeding in a small 50 cycle voltage to the anode, grid or cathode circuits. A very convenient feed point is across the cathode resistor common to the two multivibrator valves, this resistance therefore being shown as a 500 ohms potentiometer. By earthing one side of the heater circuit the locking input can be taken to the other side of the heater winding on the mains transformer to obtain a 50 cycle locking signal.

The locking input amplitude should be kept as low as possible—in the diagram of Fig. 31 the arm on the cathode potentiometer should be kept as near to the earthed end as possible—since over-injection of the locking frequency, especially when it is so much lower than the multivibrator frequency, will endeavour to "drag" the multivibrator frequency to a less widely spaced harmonic. Thus, as the locking potentiometer is turned up,

the multivibrator's harsh note at the free running position will turn to a purer tone, and then, as the locking is increased, will suddenly jump to a slightly lower frequency. The multivibrator will then be running at 450 instead of 500 cycles, and further injection of locking potential will cause another drop in tone.

The multivibrator fundamental can also be made a high frequency, say, of 10,000 cycles.

One widely-used multivibrator has a fundamental frequency of 10 kcs. locked to a 100 kcs. crystal oscillator. The stability of the multivibrator is then as good as is that of the crystal, and the multivibrator output consists of a very wide range of harmonics each separated from the next by 10 kcs. Such a circuit is of considerable value for calibrating gear and receivers, the signal being tuned at every 10 kcs. point as a strong, unmodulated carrier.

The fundamental frequency of the multivibrator circuit is set by the capacitances and resistances used in the grid circuits, and the grid leaks should be kept at a fairly low resistance, not above 100,000 ohms. The frequency for any combination may be found from the formula

$$F = \frac{1,000}{R1C1 + R2C2}$$

where F is in kcs., C1 and C2 are the two grid capacitances in mfd., and R1 and R2 are the grid leak values in ohms.

For a fundamental frequency of 500 cycles the values given by the formula are very close to the standard values of 47,000 ohms for the grid leaks and 0.02 mfd. for the grid condensers, and the locking from a 50 cycle circuit will pull the multivibrator using these values to 500 cycles with no trouble.

To use the multivibrator at 10 kcs., the same formula gives suitable values as being 47,000 ohms for the grid leaks with grid condensers of 0.001 mfd. capacitance, the slight discrepancy again being countered by the locking potential.

Apart from this, however, the experimenter will already have realised that a wide range of fundamental frequencies may be obtained by using a variable resistance for one or both of the grid leaks. A 100,000 ohm potentiometer in each grid circuit in place of the grid leak, bearing in mind the fact that the multivibrator may be locked to frequencies as far separated from the fundamental as the tenth harmonic or sub-harmonic, will give a test instrument with a wide frequency range which may be locked for many of its ranges to the 50 cycle mains frequency, whilst a two-leaf selector switch capable of switching in a number of different grid condensers will further multiply the frequency range.

Components List for the Multivibrator, Fig. 31.

C1,	0.001 mfd. Mica.
C2, C3,	0.02 mfd. 350 v.v. for 500 cycles, 0.001 mfd. Mica for 10,000 cycles, or intermediate.

C4,	1 mfd. for 50 cycles locking. Reduce for higher frequency locking to 0.001.
R1,	100,000 ohms variable, output control.
R2, R4,	33,000 " } watt.
R3, R5,	47,000 " } " or 100,000 ohms variable.
R6,	500 ohms variable.
V1, V2,	Similar triodes of almost any characteristics, 4 or 6-volt heaters, or a double triode.

To test the injection of a locking voltage in the grid circuit, use a 33,000 ohm fixed resistance in series with a 10,000 ohm potentiometer in place of either grid leak. The potentiometer should be connected at the earthed end of the pair, and the injected potential applied between its moving arm and earth.

The I.F. trap is only required when the multivibrator is to be used for testing broadcast superhets, the fundamental being an audio note such as 500 cycles. The trap may be made up of a single I.F. coil taken from an old I.F. transformer with its associated condenser, or may be an iron-cored I.F. trap coil.

THE BOLOMETER BRIDGE

The experimenter who requires at times to measure low R.F. currents is often unable to do so since the usual thermo-couple or the older hot-wire ammeter both have a cramped scale and are incapable of measuring currents of the order of milliamps. The valve voltmeter can, of course, measure the voltage drop across a resistance caused by a current flowing through the resistance, but this method is of very little practical use since, even if it is convenient to pass the current to be measured through a resistance, any inductance in the resistive circuit will give a false reading.

The bolometer bridge is easily made and, by using different lamps in the circuit of Fig. 32 can be made to measure currents of quite widely differing amplitudes.

The two arms of the bridge, A and B, are made of small lamps or bulbs, one having an R.F. choke connected in series on either side of it to prevent the R.F. current under measurement from flowing through the rest of the circuit.

The other two arms of the bridge are made up of resistances similar in value to the lamp resistances when cold, although since the arm D has a balancing rheostat in circuit the resistance values are far from critical.

The R.F. to be measured is then applied across lamp A, the bridge having been balanced, and with D.C. flowing. The lamp heats up to a higher temperature than lamp B, the filament resistance therefore increasing, so that the bridge is unbalanced and the galvanometer, G, deflects. This deflection should be noted, and the R.F. current switched off. When the bridge is again in balance, the lamp temperature having fallen to that of B, a D.C. current is applied to the arm A across the two input points. The lamp will

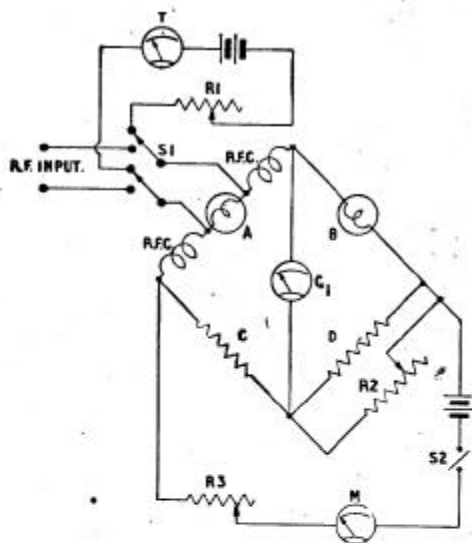

FIG. 32. The Bolometer R.F. Bridge.

again heat up, and since the heating effects of D.C. and R.M.S. A.C. are the same, the D.C. current to produce the same galvanometer deflection as was given by the application of the R.F. current will be equal to the R.F. current, so that the R.F. current is measured by substitution. The only point where care must be observed is that the current registered by the milliammeter M is the same for the R.F. and D.C. input readings. When D.C. is applied across lamp A, a D.C. current will also flow through the bridge, assisting or opposing the current from the bridge battery. The galvanometer deflection must therefore be produced, when D.C. is connected across A, by combined adjustment of the D.C. input and the bridge supply rheostat, the circuit being given time to settle down between adjustments since there is some slight time-lag in the filament's heating and cooling effect.

Components List for the Bolometer R.F. Bridge, Fig. 32.

- | | |
|-------|---|
| A, B, | Lamps. Test 6.3 v. 0.3 amp., 100 mA.
fusebulbs, etc. |
| C, D, | 20 ohms to 100 ohms. |
| | 60 |

- | | |
|---------|---------------------------------------|
| R1, | 0-5,000 ohms variable, wirewound. |
| R2, | 0-500 ohms variable, wirewound. |
| R3, | 0-50 ohms variable, wirewound. |
| C, | Galvanometer. |
| M, | 0-100 mAs. |
| T, | 0-50 mAs. |
| S1, | D.P.D.T. low-capacity switch. |
| S2, | S.P.S.T. On-Off switch. |
| R.F.C., | Wound to suit frequency range in use. |

The resistance of the R.F. chokes must be made as low as possible, to avoid upsetting the bridge-balancing point.

BANDSPREAD Shortwave Converter

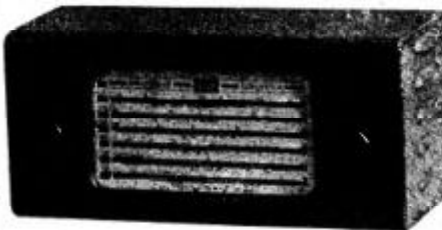

Model 1. 11-12, 13.5-14.8, 16-17.4, 24-26, 30-32.9, 41-44.5 Metres.
Retail Price Complete, £13.1.6. Less power pack, £9.9.6.

Model 2. Television Sound, 10-11.8, 20.5-22.5, 41-44.5, 78-86, 150-190 Metres.
Retail Price Complete, £13.5.0. Less power pack, £9.12.6.

This unit provides BANDSPREAD Short-wave reception and 7 inches of dial space on each of the six bands covered. Can be easily fitted externally to most medium wave radios. Model 1 for Broadcast Bands, Model 2 for Television-Sound, Amateur and Shipping Bands. Supplied with built-in power pack for A.C. Mains, or without where practicable to draw supplies from existing radio.

Full details and leaflets available from:

RUCO PRODUCTS 197, LOWER RICHMOND ROAD,
RICHMOND, SURREY. Tel. PPOspect 7463

RADIO COMPONENTS

YOU Can Rely on US

Quick Dispatch of
QUALITY Goods from
Stock

Write for Price List,
Telephone, or Call

RADIO SERVICING CO.

444, WANDSWORTH RD.,
S.W.8.

Tel: MACaulay 4155

Recently Published

LOUDSPEAKER MANUAL

by
"RADIOTRICIAN"

Many tested circuits and designs are shown for the construction of all types of speakers with full frequency response, baffles, labyrinth type horns, exponential horns, etc. Design data are given on the high frequency response and bass boost sections of reproduction, also extensive information on the construction of specialised apparatus for the improvement of every type of loudspeaker.

2/6 net

BERNARDS (PUBLISHERS) LTD.
THE GRAMPIANS,
WESTERN GATE, W. 6.

OPPORTUNITIES IN RADIO

Get this FREE Book!



"ENGINEERING OPPORTUNITIES" reveals how you can become technically-qualified at home for a highly-paid key-appointment in the vast Radio and Television Industry. In 108 pages of intensely interesting matter it includes full details of our up-to-the-minute home-study courses in all branches of **RADIO AND TELEVISION**, A.M.Brit. I.R.E., A.M.L.E.E., City and Guilds, Special Television, Servicing, Sound Film Projection, Short Wave, High Frequency, and General Wireless Courses.

We definitely guarantee

"NO PASS — NO FEE"

If you're earning less than £10 a week this enlightening book is for you. Write for your copy today. It will be sent FREE and without obligation.

BRITISH INSTITUTE OF ENGINEERING TECHNOLOGY
511, SHAKESPEARE HOUSE, 17, STRATFORD PLACE, LONDON, W.1.

HENRY'S

Radio Component Specialists

We have the most comprehensive range
of Radio Components of every nature.

Over 10,000 Valves in Stock.

Our reputation is your guarantee.

Situated opposite Edgware Rd. Tube.

If unable to call, please send stamp
for current price list

(Dept. B.P.)

5, Harrow Road, W.2.

PADdington 1008/9.

POST RADIO SUPPLIES

33 BOURNE GARDENS
LONDON, E.4

Offer from Stock

COPPER INSTRUMENT WIRES.
ENAMELLED, TINNED, COTTON
AND SILK COVERED. LITZ WIRES.
B.A. SCREWS, NUTS, WASHERS,
SOLDERING TAGS, EYELETS AND
RIVETS.

LAMINATED BAKELITE & EBONITE
PANELS. TUFNOL AND EBONITE
ROD. PAXOLIN type tubes and
coil formers. All diameters.

Permanent detectors, crystals, head-
phones, etc., etc.

Send S.A.E. for List. Trade Supplied
Distributors of Bernard Publications.