



catalog RA.1011A

(Replaces B.6004)

One-Kilowatt AM Transmitter, Type BTA-1S

- Excellent frequency response, low distortion
- Low operating costs
- Circuit breaker overload protection
- Positive peak modulation capability: 125%

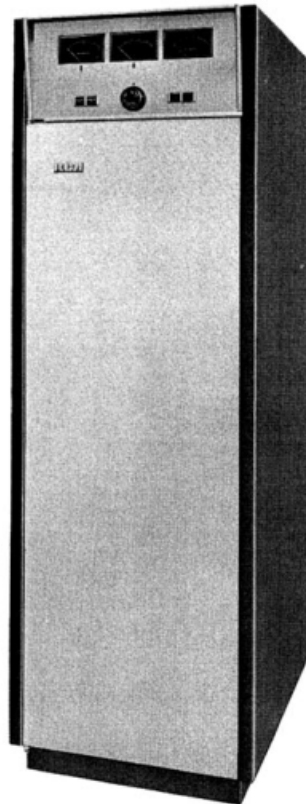

The RCA Type BTA-1S, 1-kilowatt AM Broadcast Transmitter is designed for reliability, outstanding fidelity, and economical operation. It provides a high quality amplitude modulated signal at any frequency in the 535 to 1620 kilohertz band and is capable of producing a maximum of 1100 watts.

Highly perfected audio circuits together with a large, high-quality modulation transformer and reactor provide 125-percent positive-peak modulation capability and unusually high fidelity sound. Stable, long-life tubes and solid-state devices have been used throughout the transmitter. Circuit breakers, *not fuses*, provide complete overload protection.

Provision for remote control and simplified power cutback are reflected in the BTA-1S design. Front panel or remote control selection of any two power levels of 1000, 500 or 250 watts is available. No unnecessarily complicated circuitry or superfluous parts have been included and all components are easily accessible for maintenance and inspection.

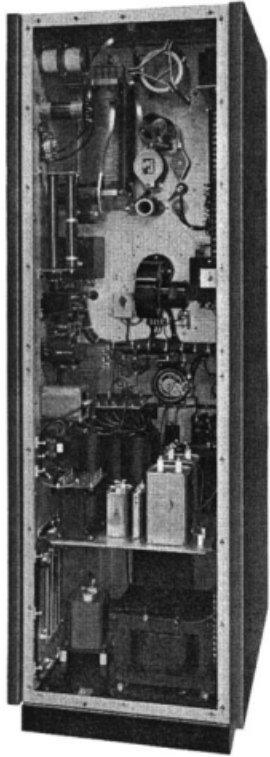

Unimpeded rear access to the transmitter is afforded by the full length door and the well laid out, vertical construction. Power supply components at bottom; r-f components at top.

Type BTA-1S Transmitter with outer and inner door open to display accessibility to the tubes. Power amplifier and modulator tubes are near top while the lower chassis carries the audio-amplifier and intermediate stages.

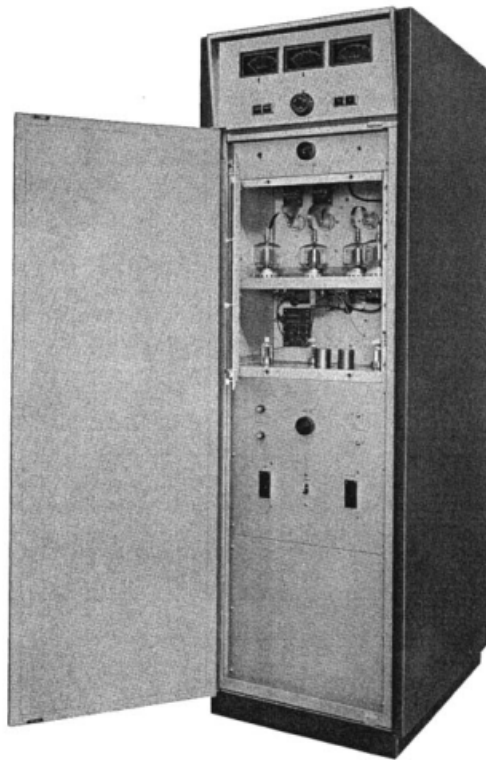

Functional Design

Improved functional design includes RCA's new color combination. Square construction permits locating the transmitter against the wall, or it can be installed against other equipment. The vertical construction makes it accessible from both front and rear for ease of maintenance. A single front panel tuning control provides simplified operation. Remote control provisions permit unattended operation of the transmitter.

Simplified Power Cutback

The BTA-1S easily fits into operations where power reduction at night is required. For "day-night" operation an optional Power Cutback Kit may be incorporated in the transmitter. By pressing a button on the front or at a remote panel, the transmitter can be cut back in power to either 500 or 250 watts. Efficient operation at the low power levels is achieved by reducing the high voltage by primary taps on the plate transformer.

Complete Accessibility

The entire transmitter is housed in a single steel cabinet that is mounted on a sturdy welded steel base. Control components are conveniently located on the panel above the front door and all meters are at eye level. Easy access is provided by a hinged front door and two interlocked removable rear panels. Most BTA-1S components are mounted on a vertical center chassis. Tubes and overload relays are mounted on the front and the other components are mounted on the rear. Larger power components are mounted on the base.

Solid State Power Supplies

Three power supplies are used: a low voltage supply for plate and screen voltages of all low voltage tubes, a bias supply for the modulator tubes, and a high voltage supply for the modulator and power amplifier tubes. All power supplies use silicon diodes which results in low power drain, cool operation and reliable performance. Automatic relays protect the transmitter against overload. These, in turn, are backed up with automatic circuit breakers. The design avoids the use of fuses anywhere in the unit.

Power Requirements

The transmitter operates from a 208-240-volt, 50/60-hertz, single-phase power source, for the main power. In addition, the crystal heaters require 115-volt power source.

Solid-State Oscillator and Buffer Stages

Adding an extra measure of transmitter stability, the BTA-1S combines its oscillator and buffer amplifier into a single, solid-state subassembly. The combination of transistorized electronics and temperature-controlled crystals make for an adjustment-free facility which, in turn, reduces routine maintenance. The oscillator is equipped with two temperature-controlled crystals arranged through a front-panel selector switch so that a "hot" spare is always at hand, even via remote control.

Simple, Straightforward Circuitry

The buffer feeds a single 6146A driver tube which in turn feeds the power amplifier which consists of two 4-400A tubes connected in parallel. Tetrodes have been utilized throughout the RF section of the transmitter reducing the required stages and the power consumption. Tetrodes also eliminate the need for neutralization.

The modulator comprises two 2E26 tubes in push-pull, resistance coupled to two 4-400A modulator tubes. The modulator tubes operate as a class AB₁ ampli-

fier without grid current which results in an overall distortion of less than 2 percent up to 10,000 Hz.

Parallel/Redundant System

The BTA-1S is available also as a parallel/redundant transmitter system. This system consists of two identical BTA-1S transmitters and a combiner. In the "parallel" mode, the twin one-kilowatt outputs are combined to provide two kilowatts of power to the antenna system; in the "redundant" mode, the system operates one of the two transmitters as a hot standby while the other feeds the antenna system.

In either operational mode, the parallel/redundant system assures greater on-air dependability. For example, an outage in one transmitter or the other automatically switches the troubled transmitter to a dummy load while the operable one feeds a full kilowatt to the antenna system. This action is the result of a special-design combiner with essentially zero insertion loss. Further details of the BTA-1S parallel/redundant transmitter system are available from Aural Broadcast Equipment Marketing, RCA Building 2-5, Camden, N. J. 08102, U.S.A.

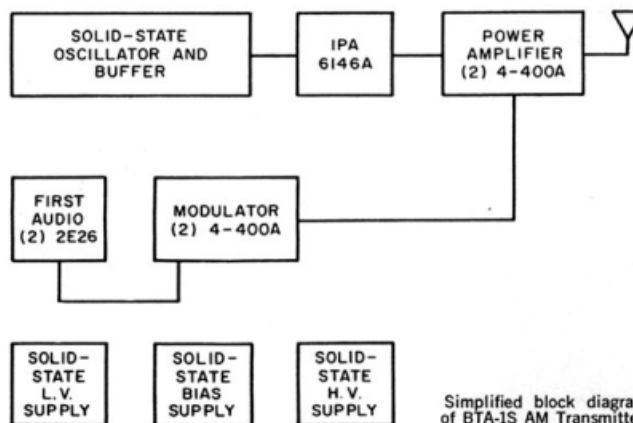

Simplified block diagram of BTA-1S AM Transmitter.

Specifications

Performance

AF Input Impedance	150/600 ohms
AF Input Level (100% modulation)	+10 ±2 dBm
AF Response:	
50-7500 Hz	±1 dB
30-10,000 Hz	±1.5 dB
AF Distortion (95% modulation):	
50-10,000 Hz	2%
50-12,000 Hz	3%
Noise (below 100% modulation)	60 dB
Frequency Range	535-1620 kHz
Frequency Stability	±2 Hz
Type of Output	Single ended
Carrier Shift (0-100% modulation)	3%
Output Impedance	40-250 ohms

Electrical

RF Voltage (for frequency monitoring)	6/10 V rms 75 ohms
RF Voltage (for modulation monitoring)	6/10 V rms 75 ohms
Power Output (nominal)	1000 watts
Power Output Capability	1100 watts
Power Supply	208/240 volts
Line Frequency	50/60 Hz
Phase	Single
Power Consumption (Approx.):	
0% modulation	2900 watts
100% modulation	3900 watts
Average program modulation	3200 watts
Power Factor	90%
Permissible combined line voltage variation and regulation	±5%
Crystal Heater Power Supply	115 volts 50/60 Hz

Tube Complement

1	6146A	Intermediate Power Amplifier
2	2E26	Audio Frequency Amplifier
2	4-400A	Modulator
2	4-400A	Power Amplifier

Mechanical

Height	77" (1955 mm)
Width	26" (660 mm)
Depth	30" (762 mm)
Weight (net)	900 pounds (408 kg) (approx.)
Altitude Range	0-5000 ft.* (0-1254 m)
Ambient Operating Temperature	-20 to 45°C (-4 - 113°F)
Shipping Data	1200 lbs (544 kg); 79 ft ³ (2.23 m ³)

Accessories

Operating Spare Tube Kit	ES-560655
Recommended Minimum Spare Tube Kit	ES-560656
Frequency and Modulation Monitor, Type BW-50	MI-560767
RF Amplifier (for BW-50)	MI-560762
Thirty-Function Remote Control, Type BTR-15	MI-561150
Sixty-Function Remote Control, Type BTR-30	MI-561440
High-Altitude Blower Kit	MI-34309-8
Spare Crystal Unit, Type TMV-130 (Specify Freq.)	MI-27493
RF Ammeters	MI-7157-F Series
Remote RF Pickup Unit (less meter)	MI-27966-B
Power Cutback Kit (Two Level)	MI-560657
Remote Power Adjust Kit	MI-560658
Oscillator-Buffer (Solid-State)	MI-27592

Ordering information

One-Kilowatt AM Transmitter, Type BTA-1S	ES-560650
250- or 500-Watt AM Transmitter, Type BTA-1S (Specify power level)	ES-560947

*To 10,000 ft. (3048 m) with optional blower (MI-34309-8).